

**RoHS COMPLIANT**

REVISIONS				
REV.	ECN NO.	DESCRIPTION	DATE	APPROVAL
1	--		2021/1/13	

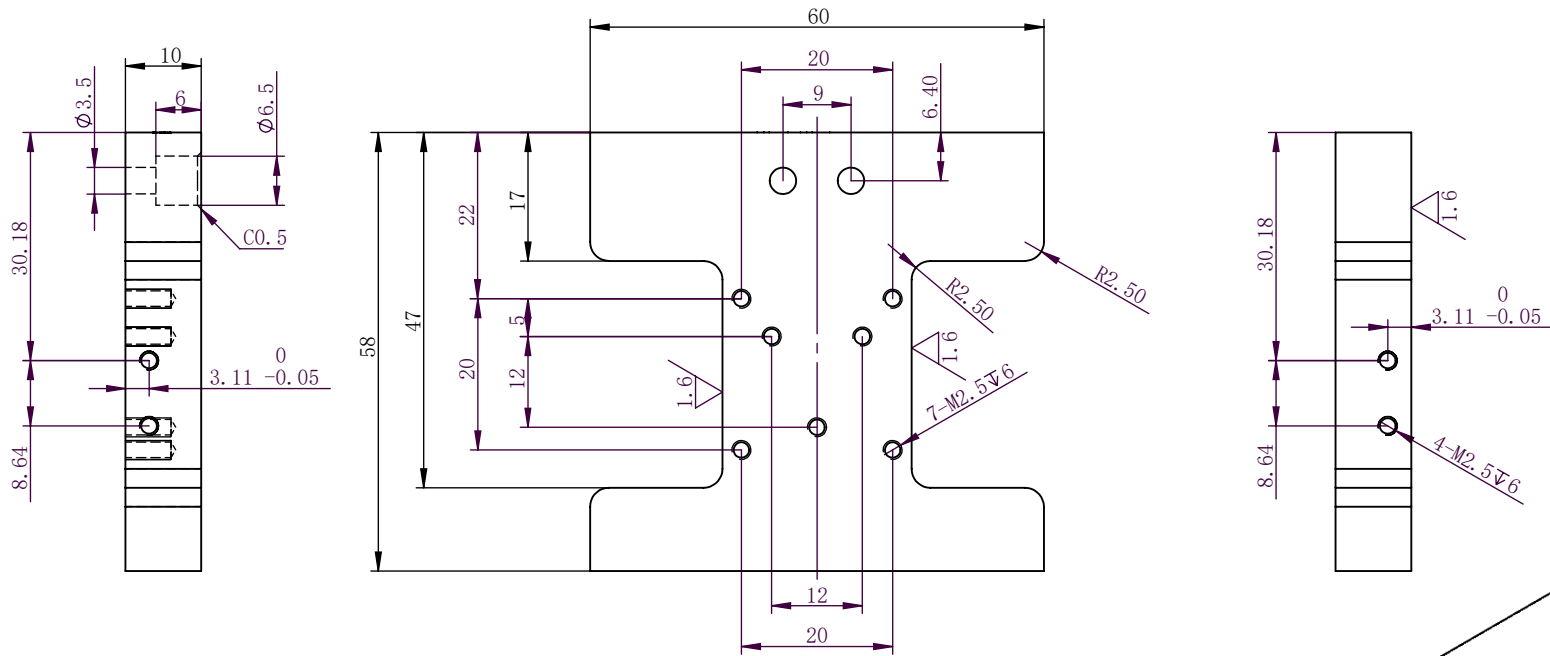

TFF-14012-01

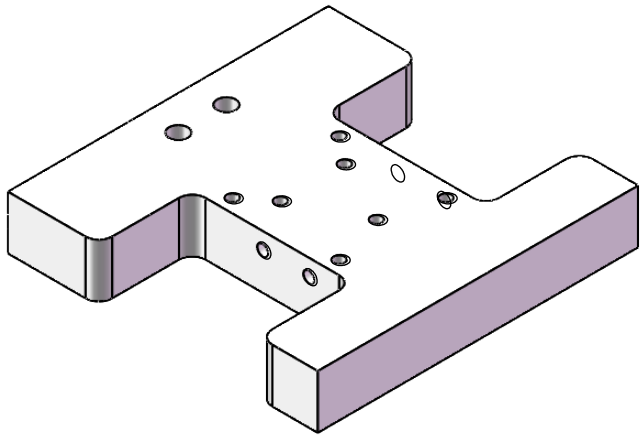

NOTES:

1. MATERIAL: BRASS
2. FINISH: N/A
3. ANY UNDIMENSIONED FEATURES TO MEET CAD FILE
4. UNLESS OTHERWISE SPECIFIED, REMOVE ALL BURRS VISIBLE WITHOUT MAGNIFICATION
5. ALL THE DIMENSIONS MUST BE INSPECTED BY IQC.

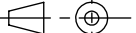
PART NAME: 测试治具底座	Designed	TZ. Wang								
	Check									
DRAWING NO. TFF-14012-01	Approval		TOLERANCES ON							
	Sheet 1 of 1		DECIMALS      ANGLES							
DESCRIPTION: Fixture Base	Scale: 1:1	Unit: mm	<table border="0"> <tr> <td>. x</td> <td>±0.10</td> <td rowspan="3">±0.5°</td> </tr> <tr> <td>. xx</td> <td>±0.05</td> </tr> <tr> <td>. xxx</td> <td>±0.02</td> </tr> </table>	. x	±0.10	±0.5°	. xx	±0.05	. xxx	±0.02
. x	±0.10	±0.5°								
. xx	±0.05									
. xxx	±0.02									