

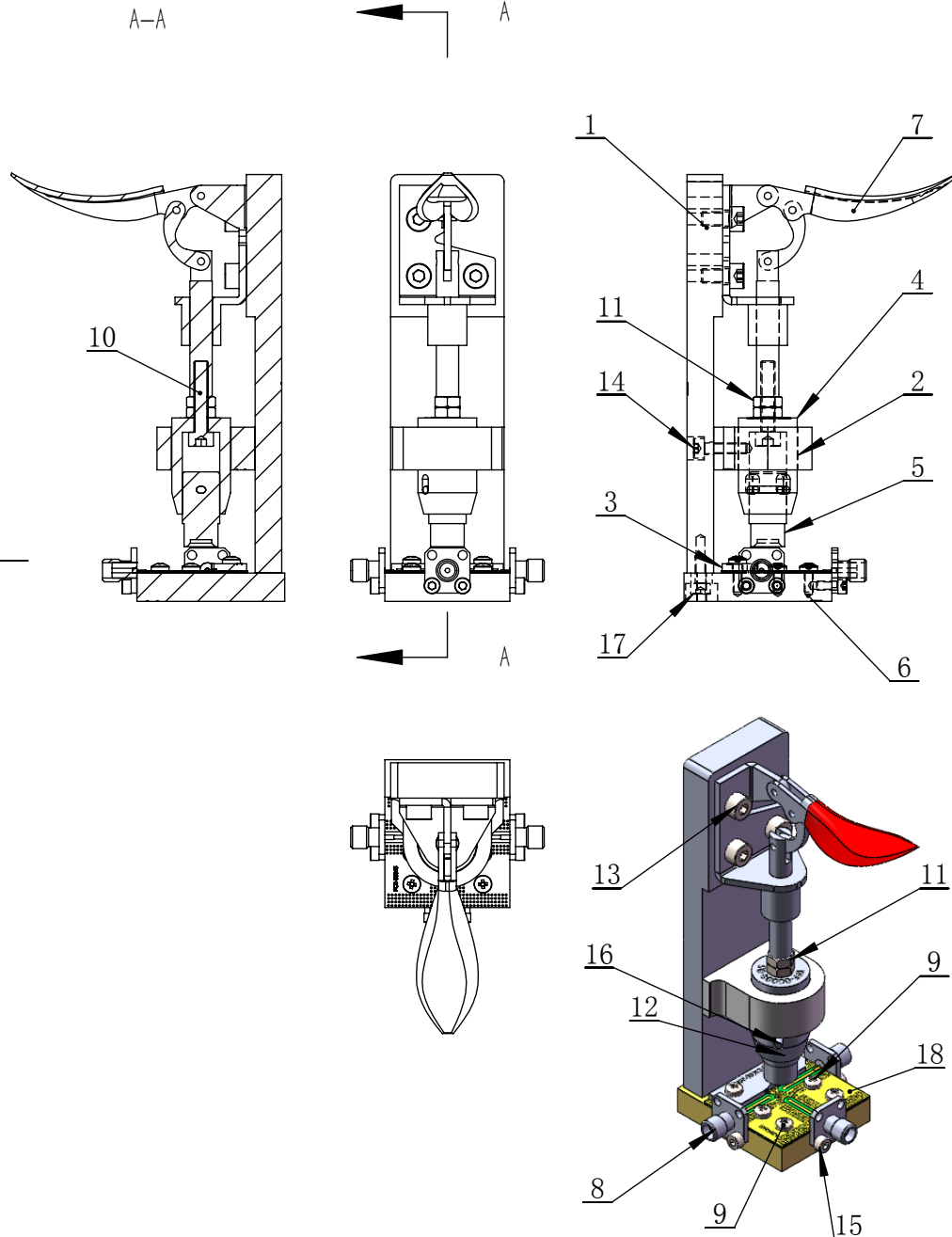

RoHS COMPLIANT

REVISIONS				
REV.	ECN NO.	DESCRIPTION	DATE	APPROVAL
A	/	Producing release	2021/2/1	

注：4和5之间内置弹簧
SPR-00001 (线径1.6x外径10x长度15)



项目号	零件号	说明	数量
1	TFF-00012-01	Fixed Block	1
2	TFF-00002-02	Guide Block	1
3	TFF-00012-02	Limited Block	1
4	TFF-00002-05	Pressure Head Fixing Seat	1
5	TFF-00012-03	Pressure Head	1
6	TFF-00059-01	Test Block	1
7	TAS-00088	GH-301-AM	1
8	CON-00001	CONNECTOR SMA-F	3
9	SCR-00001	SCREW 十字盘头 M2.5X6	4
10	SCR-00002	Screw 内六角圆柱头 M4X20	1
11	NUT-00001	M4 Nut	2
12	SCR-00003	Screw 十字盘头 M2.5X8	2
13	SCR-00004	Screw 内六角圆柱头 M4X8	3
14	SCR-00005	Screw 内六角圆柱头 M3x12	2
15	SCR-00008	M2.5X6内六角螺丝	6
16	DOW-00002	DOWEL Φ2.0 x 16	1
17	SCR-00023	Screw 内六角圆柱头 M3x8	2
18	PCB-00045	PCB	1

PART NAME: 测试夹具	Designed:	ZC. Wu		
	Checked:			
DRAWING NO. : TFF-00059	Approval:		TOLERANCES ON	
	The first angle projection: 			
DESCRIPTION: TEST FIXTURE	Sheet 1 of 1		DECIMALS	ANGLES
	Scale:	Unit:	.x ±0.10	±0.5°
	1:1	mm	.xx ±0.05	
			.xxx ±0.02	