

Customer Code: _____

DATASHEET

DAPU P/N: DPA2125M0000ECBAApplication: Automotive

DAPU			Customer Approval
Drew	Audited	Approved	Stamp, please! Thanks!
Jack	David	William	
Date: 2022.03.25			

Guangdong Dapu Telecom Technology Co.,Ltd

Building 5, No.24, Industrial East Road, Songshanhu Park, Dongguan, Guangdong, P.R. China

TEL: 0086-0769-88010888 FAX: 0086-0769-81800098

1、 Electrical Parameter

MODEL: DPA2125M0000ECBA							
No.	Parameters	SYM.	Electrical Spec.				Notes
			Min.	Typ.	Max.	Units	
1	Standard	-	Conforms to AEC-Q100				
2	Nominal Frequency	FL	25.00			MHz	
3	Oscillation Mode	-	Fundamental				
4	Frequency Stability	-	-10		+ 10	$\times 10^{-6}$	At 25°C
5	Frequency Stability	-	-25		+ 25	$\times 10^{-6}$	Over Operating Temperature Range (Reference 25°C)
6	Operating Temperature	Topr	-40	~	+ 105	°C	
7	Storage Temperature	Tstg	-55	~	+ 125	°C	
8	Supply Voltage	V _{DD}	1.62		3.63	V	
9	Input Current	I _{cc}			7	mA	
10	Output waveform	-	CMOS				
11	Output Load	CL	15			pF	
12	Output Voltage High	V _{OH}	90%			V _{DD}	
13	Output Voltage Low	V _{OL}			10%	V _{DD}	
14	Rise/Fall Time	T _r 、 T _f			4	ns	
15	Aging	-	-3		+ 3	$\times 10^{-6}$	First Year at 25°C
16	Tri-State Output Enable	-	80%			V _{DD}	Pin 1, OE
17	Tri-State Output Disable	-			20%	V _{DD}	Pin 1, OE
18	Duty Cycle	-	40	~	60	%	
19	Start-Up Time	T _{start}			3	ms	Measured from the time V _{DD} reaches its rated minimum value
20	Phase Jitter(RMS)	-			0.3	ps	12kHz to 5MHz

2、 Mechanical Structure

2.1 Dimensions

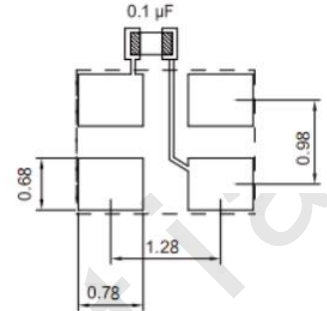
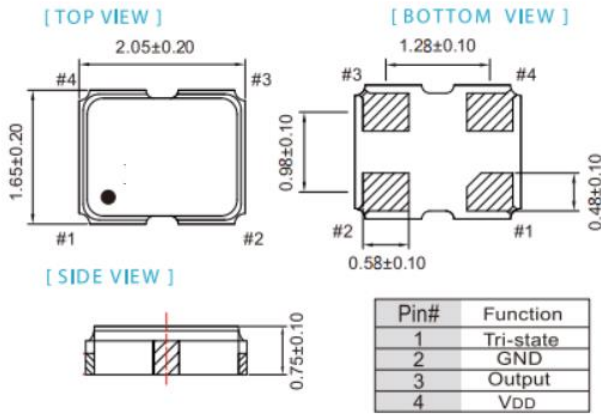

To ensure optimal oscillator performance, place a by-pass capacitor of 0.1μF as close to the part as possible between Vdd and GND pads.

Unit: mm

2.2 Marking

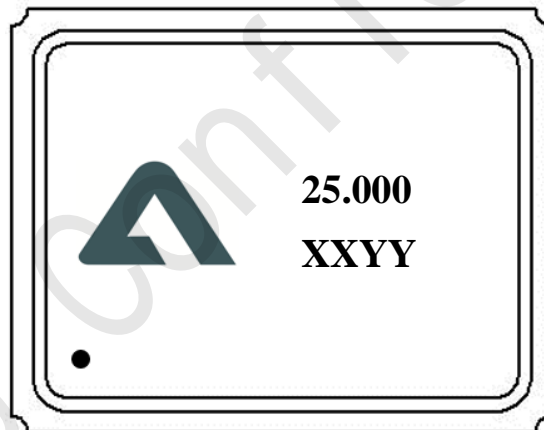

----- DAPU LOGO

25.000 ----- Frequency

XXYY ----- Manufactured day: XX YY

Year Week

• ----- Pin 1

3、 Test Circuit

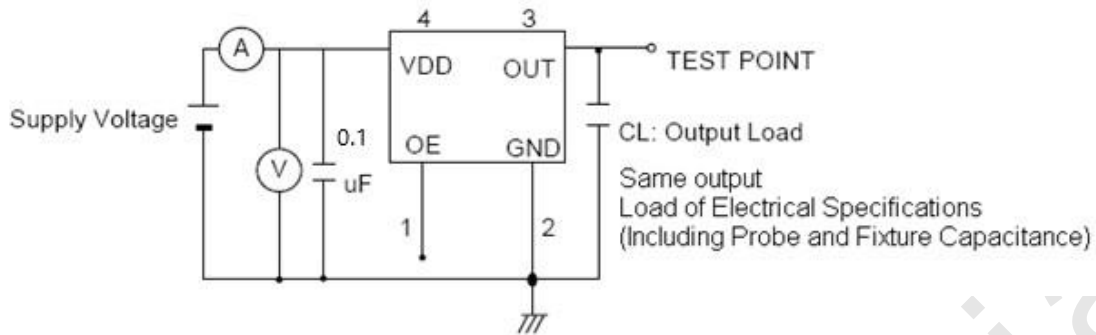

Control input (output enable/disable)

Logic 1 or open on pad 1: Oscillator output

Logic 0 on pad 1 : Disable output to high impedance

4、 Reflow Soldering Curve (RoHS)

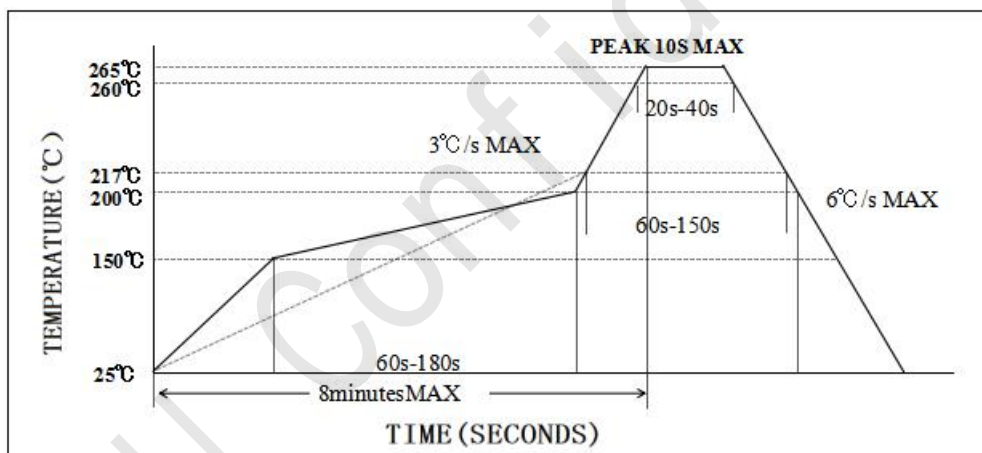

5、 Electro-static Discharges

HBM: Class3A

MM: ClassC

CDM: ClassIV

5、 Package: Tape & Reel (mm)

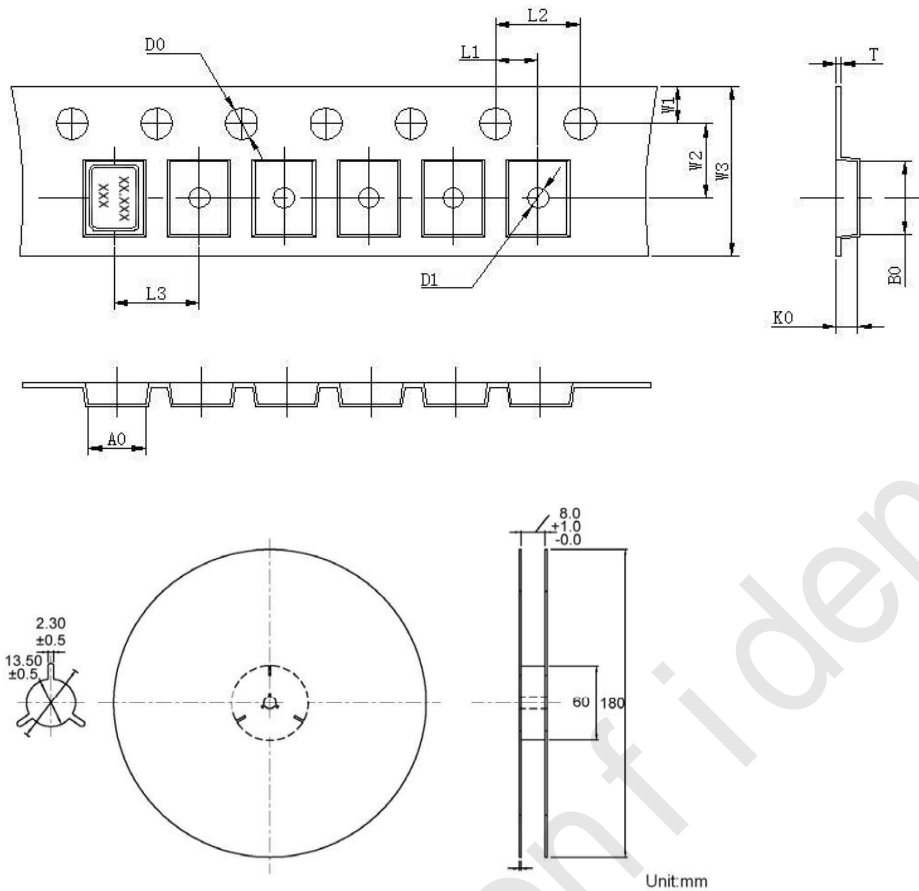

L1	2.00±0.1
L2	4.00±0.1
L3	4.00±0.1
D0	1.55±0.05
D1	1.20±0.5
W1	1.75±0.1
W2	3.50±0.1
W3	8.00±0.2
A0	2.25±0.1
B0	2.7±0.1
K0	1.45±0.1
T	0.25±0.05

6、 Reliability Test Specification

6.1 Reliability Test

NO.	Test Items	Test Standard	Test Condition	Standard
1	High temperature storage	MIL-STD-202 Method 108	The crystal was placed at a temperature of 125°C ± 2°C for 1000 hours.	A
2	Temperature cycle	JESD22 Method JA-104	Crystal do 1000 cycles according to the table below temperature. 	A
3	Temperature and humidity	MIL-STD-202 Method 103	The crystal is placed for 1000 hours at a temperature of 85°C ± 2°C and a humidity of 85% Time.	A
4	Life span	MIL-STD-202 Method 108	The crystal is placed at a temperature of 105°C ± 2°C for 1000 hours (applied rated VDD).	A
5	shock	MIL-STD-202	shock method:half sine wave 100G	A

		Method 213	Duration:6ms Direction:X, Y, Z Axial, 6 faces, 18 shocks in total.	
6	Vibration	MIL-STD-202 Method 204	Vibration frequency:10~2000Hz Vibration amplitude:1.5mm Scan time:20 min Directions:X, Y, Z (12 cycles in each of the three directions)	A
7	Resistance to soldering heat	MIL-STD-202 Method 210	Reflow soldering: Peak temperature: $260 \pm 5^{\circ}\text{C}$, time: $10\text{s} \pm 1\text{s}$.	A
8	Solderability	J-STD-002	Soldering temperature: $245^{\circ}\text{C} \pm 5^{\circ}\text{C}$ Immersion time:5 seconds \pm 0.5 seconds Flux:Rosin Resin Methanol Solvent (1 : 4)	B

6.2 Test judgment

Specification	
A	Test after 24 ± 2 hours under normal temperature and normal humidity, and meet Electrical performance requirements.
B	At least 95% of the immersed end is covered with new welding material.

Notes

- * This product meets the requirements of environmental protection standards, please contact us when you need a test report.
- *This product is suitable for automotive applications such as car multimedia, car navigation, clock, PEPS, etc., if there are applications in automobile driving safety such as engine control unit, brake system control unit, airbag, electronic stability control program, etc., please communicate with us in advance.