

Customer Code: _____

DATASHEET

DAPU P/N: DPX3132K7680125A001

DAPU			Customer Approval
Drew	Audited	Approved	
Jieshu ZHENG	Jianhua LIN	Gangtao FENG	
Date: 2024/2/28			
			Stamp, please! Thanks!

Guangdong Dapu Telecom Technology Co.,Ltd

Bldg 5, SSL Modern Enterprise Accelerator Zone, Dongguan City, Guangdong Province, PRC China
TEL: 0086-0769-88010888 FAX: 0086-0769-81800098



Table of amendment

Version	Revision contents	Prepared by	Revised date
1.0	The first issued	Jieshu ZHENG	2024/1/18

1、Electrical Parameter

MODEL :		DPX3132K7680125A001					
No.	Parameters	SYM.	Electrical Spec.				Notes
			Min.	Typ.	Max.	Units	
1	Specification	-	3215			-	
2	Nominal Frequency	FL	32.768			KHz	
3	Oscillation Mode	-	Fundamental			-	
4	Load Capacitance	CL	12.5			pF	
5	Frequency Tolerance	-	-10		10	$\times 10^{-6}$	At 25°C (Not include aging)
6	Turnover Temperature	-	20	25	30	°C	
7	Operating Temperature	Topr	-40		85	°C	
8	Storage Temperature	Tstg	-55		125	°C	
9	Drive Level	DL	-	-	1.0	μ W	
10	Equivalent Series Resistance	ESR			70	K Ω	At 25°C
11	Parabolic Coefficient	-	-0.034 \pm 0.006			ppm/°C ²	
12	Aging (first year)	-			\pm 3	ppm	25°C \pm 3°C
13	Shunt capacitance	-		0.95		pF	

2、 Dimension drawing (Unit: mm)

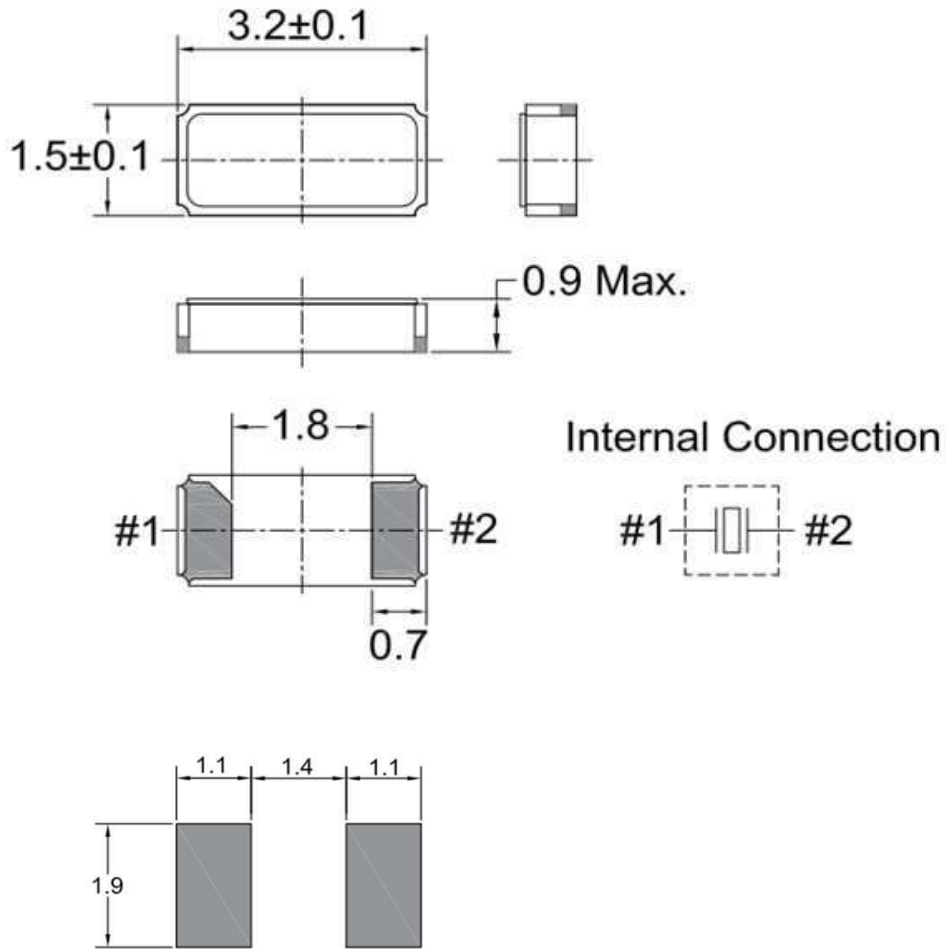

3、 Marking spec

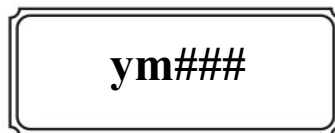

y : The last digit of production year

m : Production month (See Table.1)

: Production Lot No.

Table.1

Month	Jan	Feb	...	Sep	Oct	Nov	Dec
Code	1	2	...	9	X	Y	Z

4、Reflow soldering

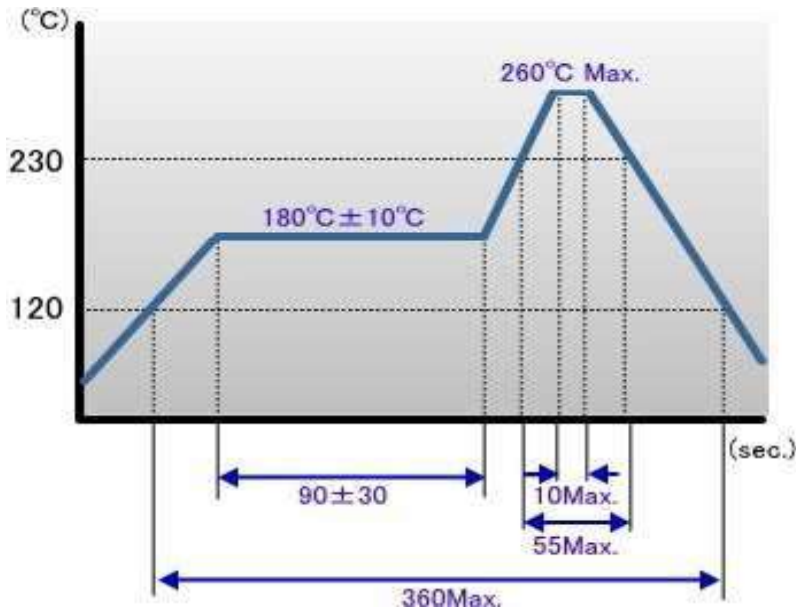

5、Package: Tape & Reel (mm)

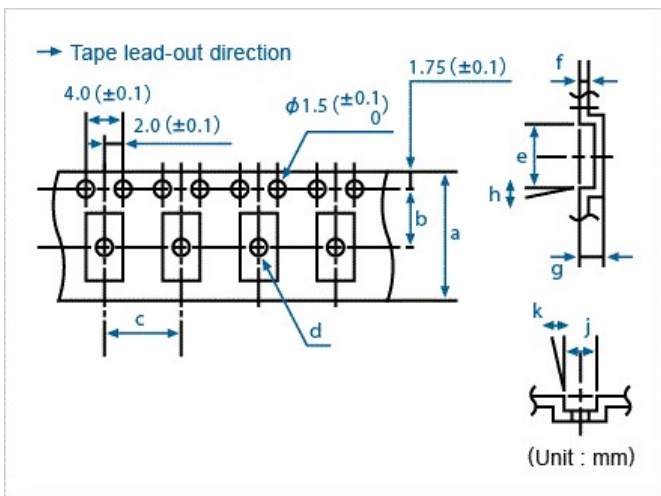

Conforming to JIS C 0806 TB1208NEIAJ and RC-1009B TE1208N

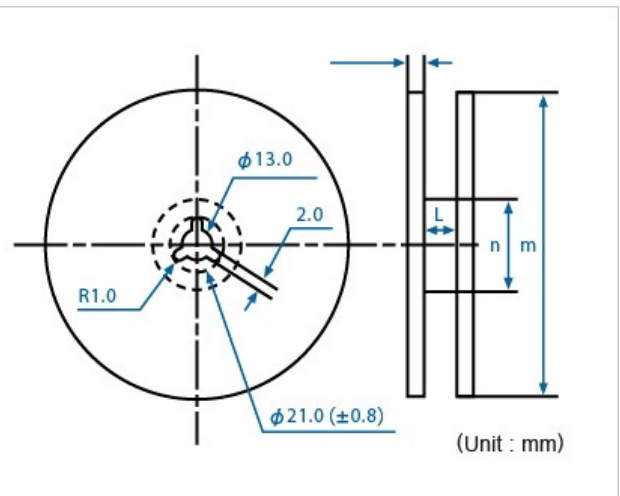

Conforming to JIS C 0806 R12R and EIAJ RC-1009B R15

Q'ty/reel	a	b	c	d (φ)	e	f	g	h	j	k	l	m (φ)	n (φ)
3,000	12.0	5.5	4.0	1.0	3.6	0.3	1.0	5°	1.9	5°	13.0	180	60

Product specifications are subject to change without notice.