

Travelling Merchant: \_\_\_\_\_

# DATASHEET

Standard: T75B-R313-38.40MHz-A

P/N: \_\_\_\_\_

Plot			The Label
Drew	Audited	Approved	Stamp, please! Thanks!
Date: 2022.12.12			

## Guangdong Dapu Telecom Technology Co.,Ltd

Building 5, No.24, Industrial East Road, Songshanhu Park, Dongguan, Guangdong, P.R. China

TEL: 0086-0769-88010888 FAX: 0086-0769-81800098





## 1. Electrical Parameters

MODEL: T75B-R313-38.40MHZ-A						
Item	Description	Parameters			Unit	Test Condition
		Min.	Typ.	Max.		
Output	Frequency	38.40			MHz	
	Output Waveform	HCMOS				
	Output Low Voltage			0.4	V	$V_{cc}=3.3V, O_{load}=10\text{ pF}$
	Output High Voltage	2.97			V	$V_{cc}=3.3V, O_{load}=10\text{ pF}$
	Duty Cycle	45	50	55	%	@50%
	Start Up Time		2	3	s	
	Rise / Fall Time (10%~90%)			10	ns	@25°C
	Load	10			pF	
Frequency Stabilities	Frequency Tolerance vs. Operating Temperature Range	-0.28		+0.28	$\times 10^{-6}$	$T_A$ varied from -40°C to 85°C, measurement referenced to frequency observed with $f_{ref}=(f_{max}+f_{min})/2, V_{cc}=3.3V, V_c=1.65V, O_{load}=10\text{ pF}$ , temperature variable speed less than 2°C per minute.
	Freq.Stability vs. Supply Voltage	-0.1		+0.1	$\times 10^{-6}$	$V_{cc}=3.3V\pm 5\%, V_c=1.65V,$
	Aging	-1		+1	$\times 10^{-6}$	First year
		-3		+3	$\times 10^{-6}$	10years
	APR	-5		+5	$\times 10^{-6}$	Sufficient range to correct for initial calibration, 15years aging, temperature, voltage, and load variations.
	Voltage Control	0		3.3	V	
	Input Impedance	10			K $\Omega$	
	Slope	Positive				
	Linearity			10	%	
	Modulation BW		6		Hz	3dB BW
	Allan Variance		0.2	0.5	$\times 10^{-9}$	Temperature stability, no EMI no EMI \EMC or other interference, test after power for 1 hour ref. to 25°C; 1s
Hold Over Stability	-0.02		+0.02	$\times 10^{-6}$	24hours with 25°C, After 48hours constant on power.	



Power Supply	Current Consumption			15	mA	@25°C, V <sub>cc</sub> =3.3V, V <sub>c</sub> =1.65V, O <sub>Load</sub> =10pF.
	Supply Voltage	3.13	3.3	3.45	V	
Phase Noise	Phase Noise @25°C		-93	-85	dBc/Hz	10Hz
			-122	-115		100Hz
			-144	-139		1KHz
			-163	-155		10KHz
			-167	-162		100KHz
			-167	-164		1MHz
Phase Jitter	Phase Jitter		70	100	fs	12KHz to 20MHz
Environmental Conditions	Operable Temperature	-40		+85	°C	
	Storage Temperature	-55		+105	°C	
	ESD Level	Human Body Model,class2: 2000V to 4000V; ANSI/ESDA/JEDEC JS-001-2010.				
		Machine Model, class B: 200V to 400V; JEDEC JESD22-A115C.				
	Moisture Sensitivity Level	Level 3.				
	Vibration	Test Condition: 0.75mm ;acceleration:10g;10Hz~2000Hz, one cycle per 30 min, test 2 hour. (3 times for each 3 directions X ,Y , Z) .IEC 68-2-06 Test Fc.				
Shock	100g; 6ms; half sine wave (3 times for each 3 directions X ,Y , Z ),IEC 68-2-27 Test Ea/Severity 50A.					
Full Package Storage	Relative humidity (%)	20%~70%				
	Temperature (°C)	-10~35°C				



## 2. Mechanical Structure(mm)

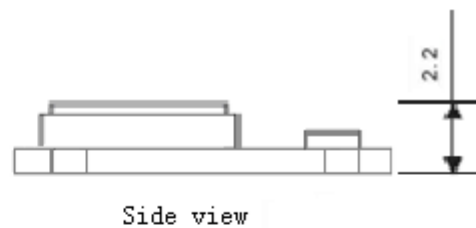
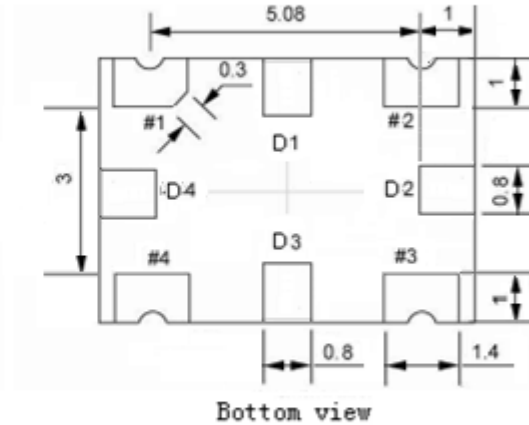
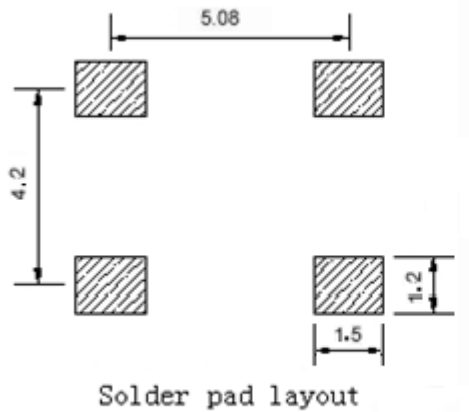

### PIN FUNCTION

PIN	NOTATION	FUNCTION
D1, D2, D3, D4	NC	Not Connect
1	VC	Control Voltage
2	GND	GND
3	OUTPUT	RF Output
4	VCC	Supply Voltage

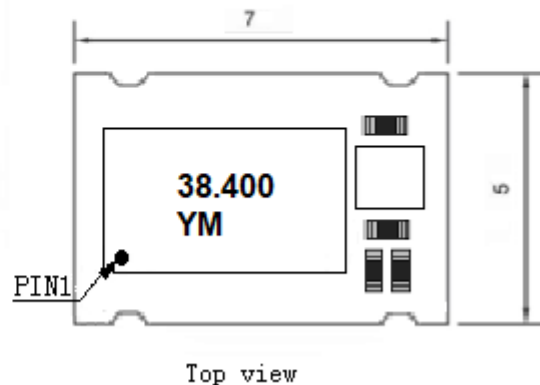

**Note1:** Tolerance  $\pm 0.2\text{mm}$  without mark

**Note2:** Referential weight 0.2g

**Note3:** Marking Frequency:

Frequency code is first 5 digits of nominal frequency (38.40MHz showed 38.400 )

Month Code.

Y:Year Code (Last One Digit)

M:Month Code (See Table)

<b>Month:</b>	1	2	3	4	5	6	7	8	9	10	11	12
<b>Month Code:</b>	1	2	3	4	5	6	7	8	9	X	Y	Z



### 3. Test circuit

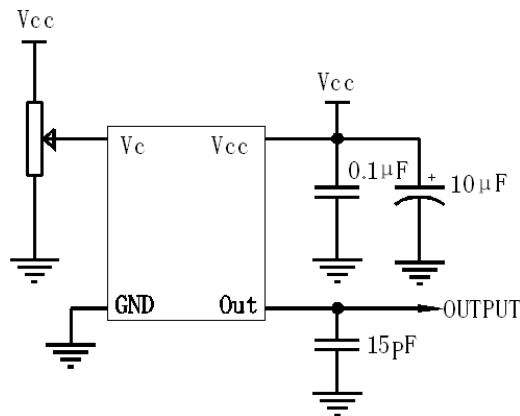

### 4. Reflow Soldering Curve (RoHS)

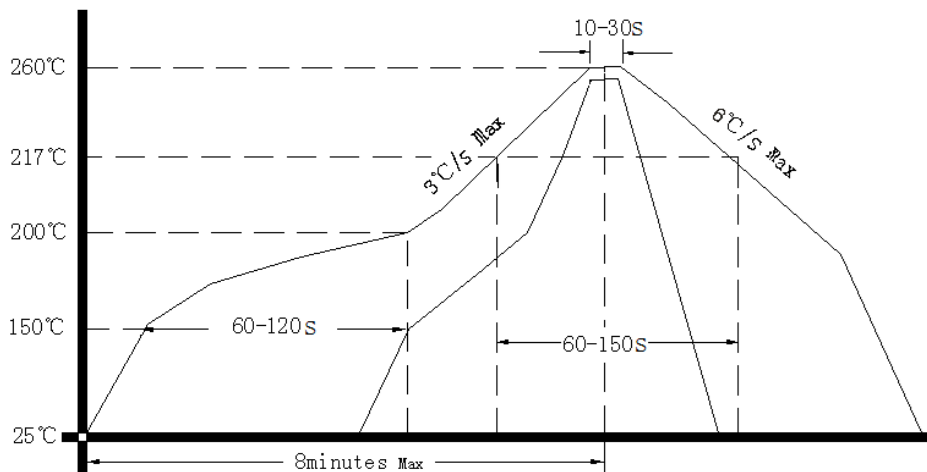

### 5. Package: Tape & Reel (mm)

