

Customer Code : _____

DATASHEET

DAPU P/N: **O22A-Q426-10.00MHz**

Customer P/N: _____

DAPU			Customer Approval
Drew	Audited	Approved	Stamp, please! Thanks!
Date: 2020.06.28			

Guangdong Dapu Telecom Technology Co.,Ltd

Bldg 16,.N.Ind.Zone,SSL Industry Park, Dongguan City, Guangdong Province, China

TEL: 0086-0769-88010888 FAX: 0086-0769-81800098



Table of amendment

Version	Revision contents	Prepared by	Revised date
1.0	The first issued	<i>Amway</i>	2017.11.01
1.1	The “Short Term Stability” “ESD Level” “Mechanical Structure” changed	<i>Amway</i>	2020.06.28



1. Electrical Parameters

MODEL: O22A-Q426-10.00MHZ						
Item	Description	Parameters			Unit	Test Condition
		Min.	Typ.	Max.		
Output	Frequency	10.00			MHz	
	Output Waveform	Sine wave				
	Level	6		10	dBm	
	Load	50			Ω	
	Harmonics Suppression			-30	dBc	
	Spurious Suppression			-75	dBc	
	Frequency Tolerance vs. Operating Temperature Range	-0.03		+0.03	$\times 10^{-6}$	T_A varied from -40°C to 85°C , measurement referenced to frequency observed with $f_{\text{ref}}=(f_{\text{max}}+f_{\text{min}})/2$, $V_{\text{cc}}=5.0\text{V}$, $V_{\text{c}}=2.0\text{V}$, $O_{\text{load}}=50\Omega$, temperature variable speed less than 2°C per minute.
	Initial Frequency Tolerance	-0.1		+0.1	$\times 10^{-6}$	Measurement referenced to frequency observed with $T_A=25^\circ\text{C}$, $V_{\text{cc}}=5.0\text{V}$, $V_{\text{c}}=2.0\text{V}$ and after 30 minutes of operation, within 30 days after ex-works.
	Frequency Tolerance vs. supply voltage	-0.2		+0.2	$\times 10^{-9}$	measurement referenced to frequency observed $T_A=25^\circ\text{C}$, V_{cc} varied from 4.75V to 5.25V, $V_{\text{c}}=2.0\text{V}$, $O_{\text{load}}=50\Omega$.
	Frequency Tolerance vs. Load	-0.2		+0.2	$\times 10^{-9}$	5% Load Change Measurement referenced to frequency observed with $T_A=25^\circ\text{C}$, $V_{\text{cc}}=5.0\text{V}$, $V_{\text{c}}=2.0\text{V}$, $O_{\text{load}}=50\Omega$.
	Short Term Stability			0.005	$\times 10^{-9}$	Temperature stability, no EMI\EMC or other interference, test after power for 1hour ref. to 25°C ; 1s.
	Aging Tolerance per day	-0.5		+0.5	$\times 10^{-9}$	$V_{\text{cc}}, V_{\text{c}}, T_A$ constant Measurement referenced to frequency observed with $T_A=25^\circ\text{C}$, $V_{\text{cc}}=5.0\text{V}$, $V_{\text{c}}=2.0\text{V}$, $O_{\text{load}}=50\Omega$ and after 30 days of operation.
Aging Tolerance 1Year	-0.05		+0.05	$\times 10^{-6}$		



Power Supply	Supply Voltage	4.75	5.0	5.25	V	
	Steady Consumption			200	mA	@25°C
	Warm up current			650	mA	
Voltage Control Characteristics	Frequency Tuning Range	-0.8		-0.4	$\times 10^{-6}$	$V_c=0V$. measurement referenced to $V_c=2.0V$.
		-0.1		+0.1	$\times 10^{-6}$	$V_c=2.0V$. measurement referenced to exactly 10.00MHz.
		+0.4		+0.8	$\times 10^{-6}$	$V_c=4.0V$. measurement referenced to $V_c=2.0V$.
	Linearity			10	%	
	Slope	Positive				
	Input Impedance	100			K Ω	
Phase Noise	Phase Noise		-95	-90	dBc/Hz	1Hz
			-125	-120		10Hz
			-145	-140		100Hz
			-155	-150		1KHz
			-160	-155		10KHz
			-160	-155		100KHz
Environmental Conditions	Operable Temperature	-40		+85	°C	
	Storage Temperature	-55		+100	°C	
	ESD Level	Human Body Model, class2: 2000V to 4000V; ANSI/ESDA/JEDEC JS-001-2010.				
		Machine Model, class B: 200V to 400V; JEDEC JESD22-A115C.				
	Moisture Sensitivity Level	Not humidity sensitive.				
	Vibration	Frequency range: 20Hz~2000Hz, acceleration : 6g , ASD:0.04g ² /Hz one cycle per 30 min, test 2 hour. (3 times for each 3 directions X , Y , Z), GJB 150.16A-2009				
Shock	100g; 6ms; half sine wave (3 times for each 3 directions X , Y , Z),GJB 360B-2009					
Full Package Storage	Relative humidity (%)	20% ~70%				
	Temperature (°C)	-10~35°C				



2. Mechanical Structure (mm)

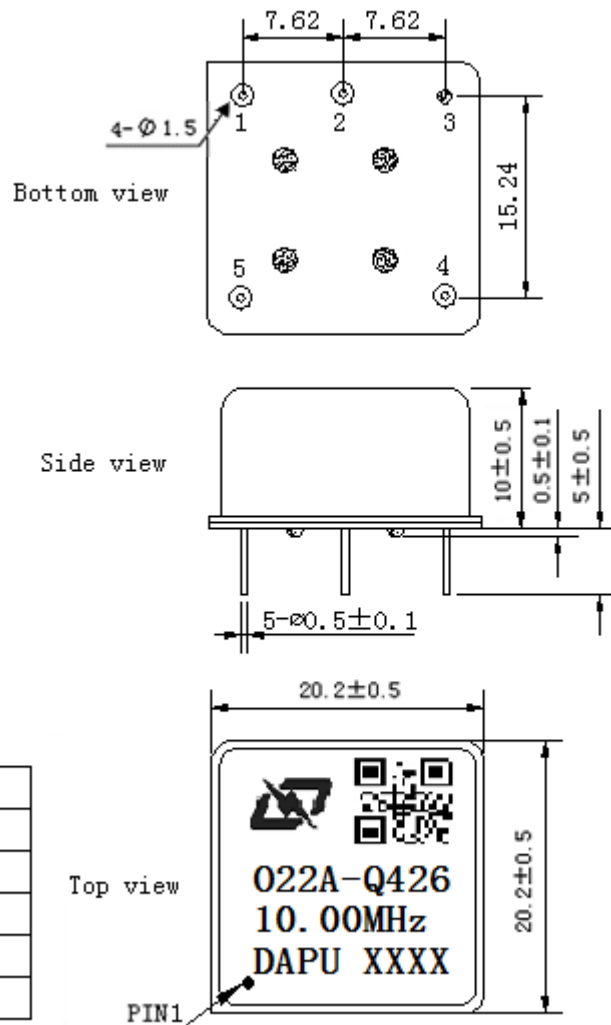

PIN FUNCTION

PIN	NOTATION	FUNCTION
1	VC	Control Voltage
2	NC	Not Connect
3	GND	GND
4	OUTPUT	RF Output
5	VCC	Supply Voltage

- Note1:** Tolerance ±0.20mm without mark
- Note2:** The first two xx representative: week
After two xx representative: year
- Note3:** Referential weight 8.0g
- Note4:** NC is not connect



3. Test Circuit

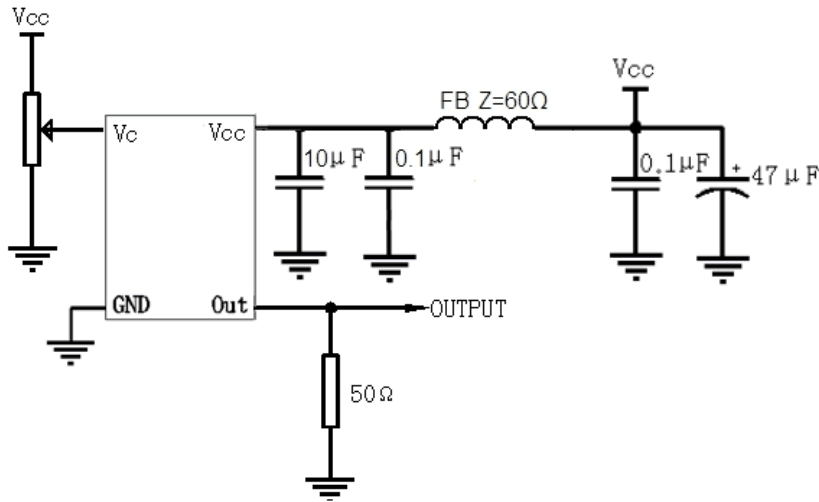

4. Reflow Soldering Curve (RoHS)

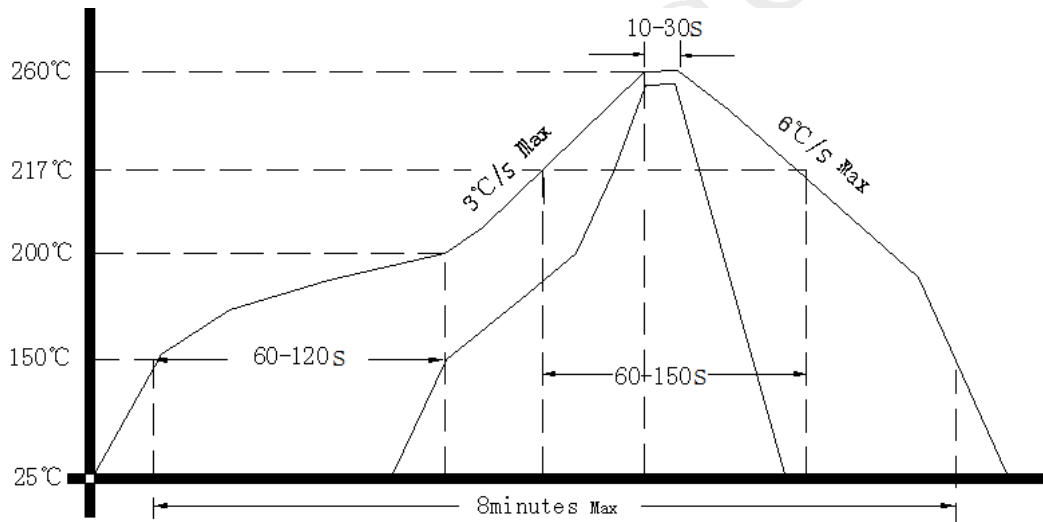

5. Package(mm)

