

RoHS COMPLIANT

A-A

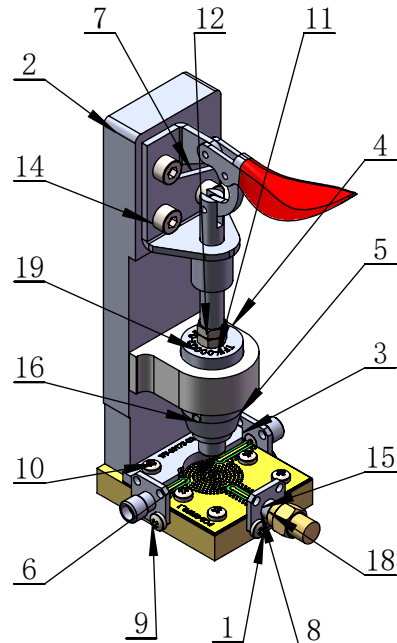
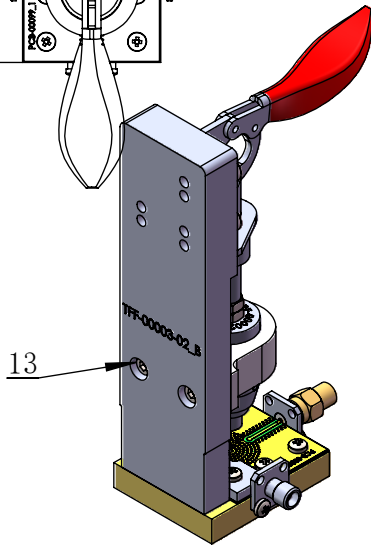
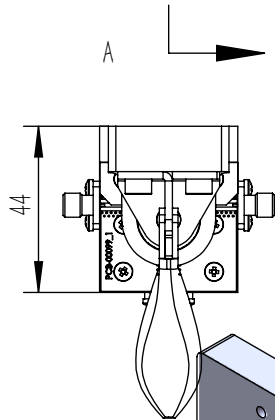
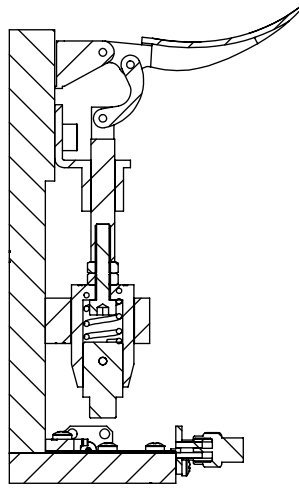
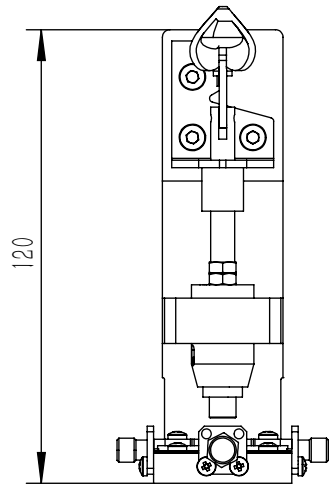

| REVISIONS | | | | |
|-----------|---------|-------------------|-----------|---------|
| REV. | ECN NO. | DESCRIPTION | DATE | REVISOR |
| A | | Producing release | 2024/3/25 | ZZ. Zhu |

| 项目号 | 零件号 | 说明 | 数量 |
|-----|--------------|---------------------------|----|
| 1 | tff-00173-01 | Test Block | 1 |
| 2 | tff-00003-02 | Fixed Block | 1 |
| 3 | tff-00173-02 | Limited Bolck | 1 |
| 4 | tff-00002-02 | Guide Block | 1 |
| 5 | tff-00002-05 | Pressure Head Fixing Seat | 1 |
| 6 | tff-00078-06 | Pressure Head | 1 |
| 7 | TAS-00088 | GH-301-AM | 1 |
| 8 | con-00004 | CONNECTOR SMA-F | 3 |
| 9 | SCR-00001 | SCREW 十字盘头 M2.5X6 | 10 |
| 10 | SCR-00003 | Screw 十字盘头 M2.5X8 | 2 |
| 11 | SCR-00002 | Screw 内六角圆柱头 M4X20 | 1 |
| 12 | NUT-00001 | M4 Nut | 2 |
| 13 | SCR-00005 | Screw 内六角圆柱头 M3x12 | 2 |
| 14 | SCR-00004 | Screw 内六角圆柱头 M4X8 | 3 |
| 15 | PCB-00099 | PCB | 1 |
| 16 | DOW-00002 | DOWEL Φ2.0 x 16 | 1 |
| 17 | SCR-00023 | Screw 内六角圆柱头 M3x8 | 2 |
| 18 | TER-00013 | SMA-50JR | 1 |
| 19 | SPR-00002 | SPRING | 1 |

| | | | | | |
|------------------------------|-----------------------------|----------|-----------|---------------|--------|
| PART NAME: 测试夹具 | Designed: | ZC. Wu | 2024/3/25 | | |
| | Checked: | ZC. Wu | 2024/3/25 | | |
| DRAWING NO. : TFF-00173 | Approval: | KL. Wang | 2024/3/25 | TOLERANCES ON | |
| | The first angle projection: | | | | |
| DESCRIPTION: TEST FIXTURE | Sheet 1 of 1 | | | DECIMALS | ANGLES |
| | Scale: | Unit: | A4 | ±0.20 | ±0.5° |
| | 1:1 | mm | | | |