

Customer Code: _____

DATASHEET

DAPU P/N: DPC53148M500AD0GEA0

DAPU			Customer Approval
Drew	Audited	Approved	
Jieshu ZHENG	Jianhua LIN	Gangtao FENG	
Date : 2024/7/31			

Stamp, please! Thanks!

Guangdong Dapu Telecom Technology Co.,Ltd

Bldg 5, SSL Modern Enterprise Accelerator Zone, Dongguan City, Guangdong Province, PRC China
TEL : 0086-0769-88010888 FAX : 0086-0769-81800098

1、Electrical Parameter

MODEL :		DPC53148M500AD0GEA0					
No.	Parameters	SYM.	Electrical Spec.				Notes
			Min.	Typ.	Max.	Units	
1	Nominal Frequency	FL	148.500			MHz	
2	Oscillation Mode	-	3rd			-	
3	Total Stability	-	-30		30	ppm	Includes initial frequency tolerance, frequency temperature coefficient, frequency voltage coefficient, Output load, 1 year aging.
4	Operating Temperature	Topr	-40		85	°C	
5	Storage Temperature	Tstg	-55		125	°C	
6	Supply Voltage	VDD	2.97	3.3	3.63	V	V _{DD} ±10%
7	Input Current	Icc			40	mA	
8	Output waveform	-	LVDS			-	
9	Output Load	CL	100			Ω	
10	Output Voltage High	VOH			1.6	V	100±1Ω (R1+R1 between OUT-OUTN)
11	Output Voltage Low	VOL	0.9			V	
12	Rise/Fall Time	Tr/Tf			0.5	ns	@20% -80%
13	Aging	-	-3		3	ppm	First Year at 25°C
14	“H”Input Voltage	-	70%VDD			V _{DD}	
15	“L”Input Voltage	-			30%VDD	V _{DD}	
16	E/D(#1)	Logic “1”Or Floating input,Outputs enable; Logic “0” ,Outputs disable					
17	Duty Cycle	-	45~55			%	
18	Start-Up Time	Tstart			10	ms	Measured from the time VDD reaches its rated minimum value.
19	Phase Jitter(RMS)				400	fs	12kHz to 20MHz

2、 Mechanical Structure

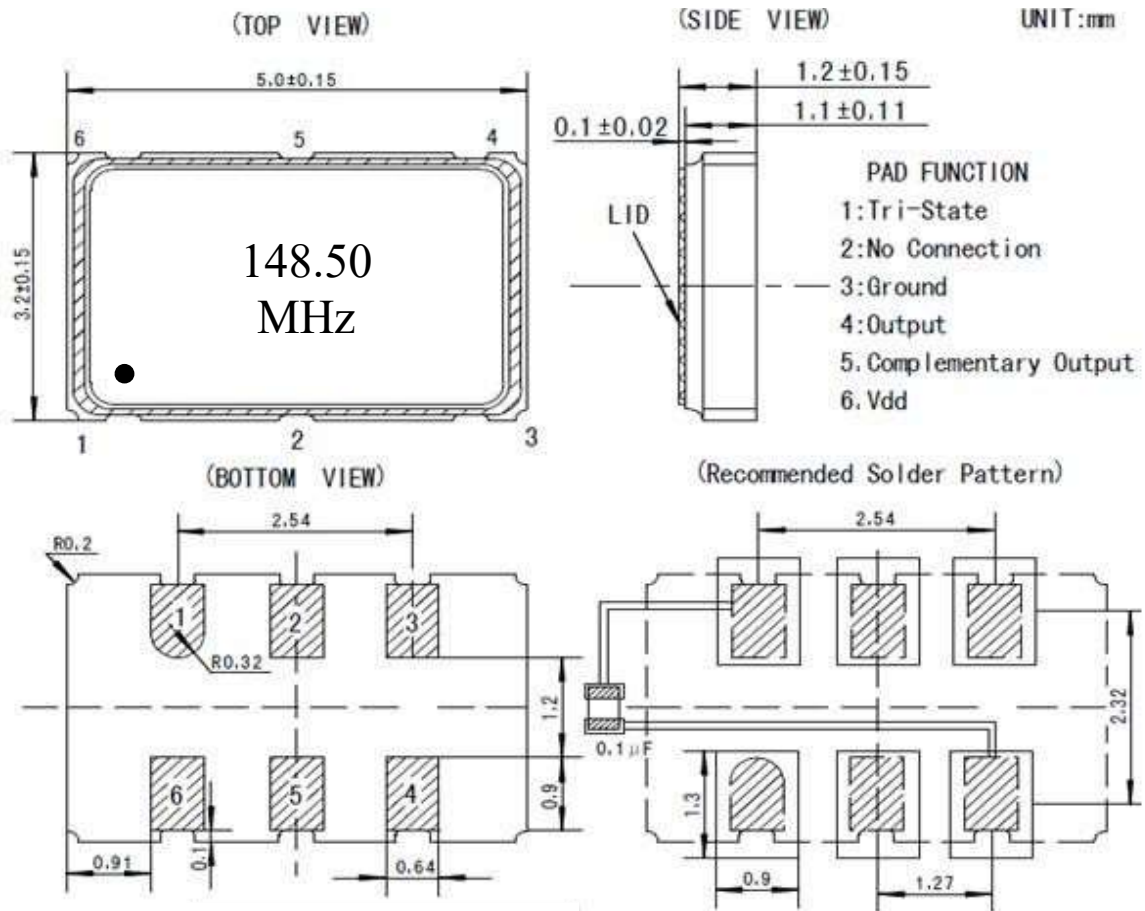

3、 Test Circuit

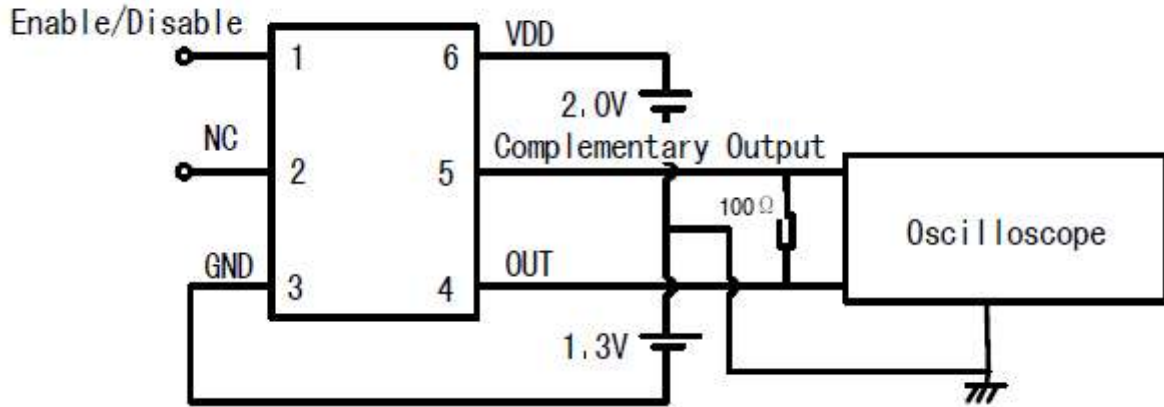

4、 Reflow Soldering Curve (RoHS)

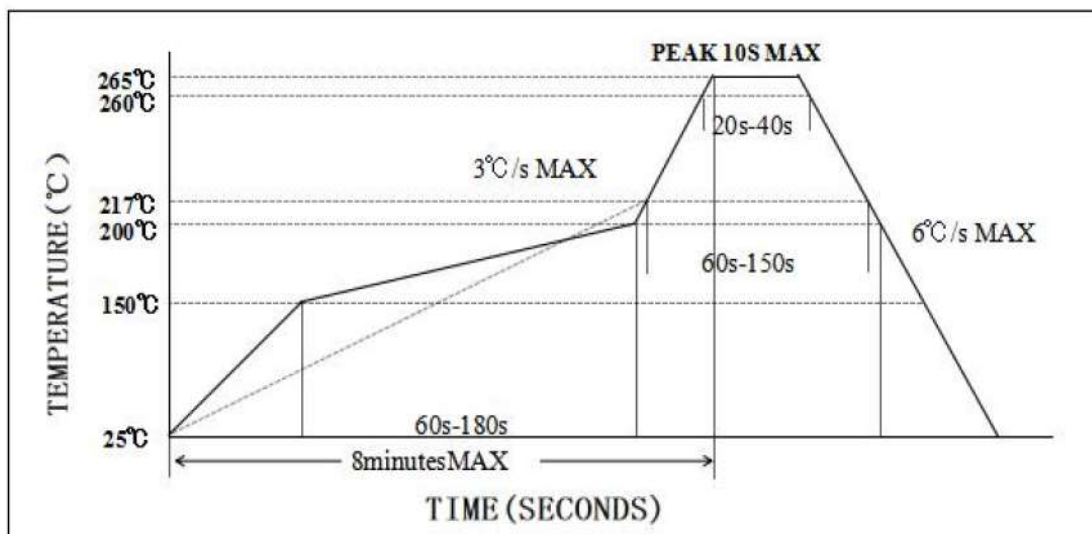

5、 Package: Tape & Reel (mm)

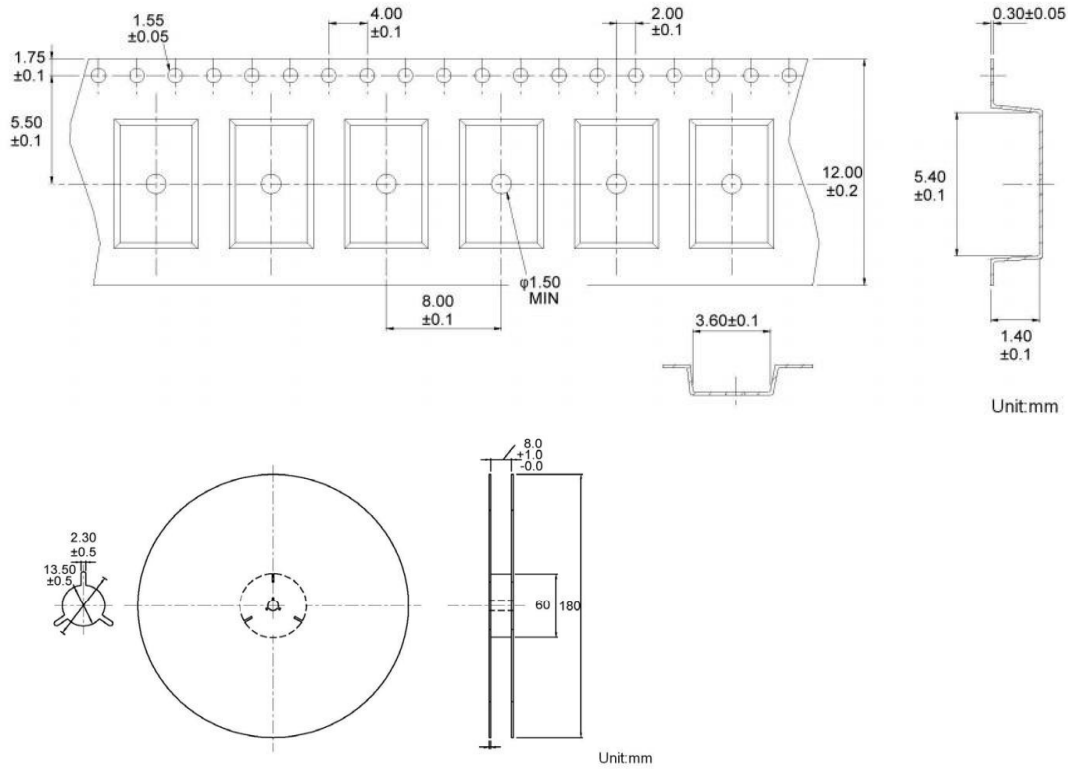

6、 Reliability Test Specification

NO.	Test Items	Test Standard	Test Condition	Standard
1	Drop test	GB/T2423.8	Drop from 150cm height on 3cm hard wooden board for 3 times	A、 C
2	Mechanical shock	GB/T2423.5	Peak: 100g; Waveform: Half-sine; Velocity Change: 1000m/s ² ; Duration: 0.5ms; 3 times/direction, Direction: +X, -X, +Y, -Y, +Z, -Z.	A、 C
3	Vibration	GB/T2423.10	Frequency: 10~2000Hz ; Vibration:20min, 1.52mm; Direction: X, Y, Z; Duration: 2 hours/direction.	A、 C
4	Solderability	IEC60068-2-58	Soldering temperature:245°C±5°C Immersion time:5 seconds ± 0.5 seconds Flux:Rosin Resin Methanol Solvent (1 : 4)	E

NO.	Test Items	Test Standard	Test Condition	Standard
5	Resistance to soldering heat	IEC60068-2-58	Reflow soldering: Solder temperature 260±5°C, Immersion time:10±1S	A、 C、 D
6	High temperature storage	GB/T2423.2	Temperature: 125°C±2°C; Duration: 500±12hours;	A、 C、 D
7	Low temperature storage	GB/T2423.1	Temperature: -40°C±2°C; Duration: 500±12hours;	A、 C、 D
8	Temperature Shock	GB/T2423.22	Do 10 cycles at the following temperature	A、 C、 D
			<p>The diagram illustrates a temperature shock cycle. The temperature starts at 25 °C, drops to -55 ± 3 °C, stays there for 30 minutes, then rises to +125 ± 3 °C, stays there for 30 minutes, and returns to 25 °C. The transition time between the high and low temperature dwell periods is 10 minutes maximum. The entire sequence is labeled as '1 cycle'.</p>	
9	High temperature high humidity storage	GB/T2423.3	Temperature: 85°C±3°C; Humidity: 85%; Duration: 500hours;	A、 C、 D