

**RoHS COMPLIANT**

REVISIONS				
REV.	ECN NO.	DESCRIPTION	DATE	REVSIOR
1	-	Producting release	2024/7/16	ZC.Wu

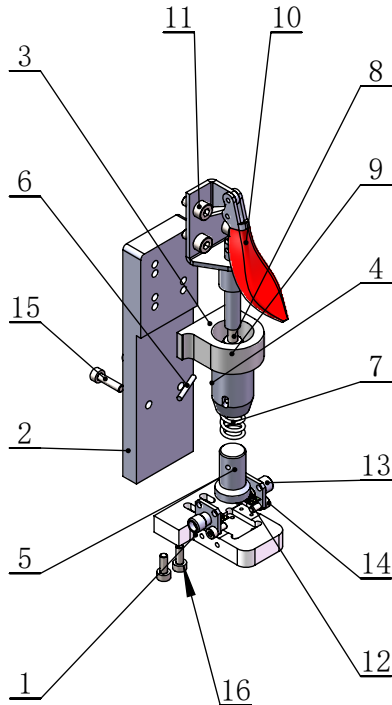
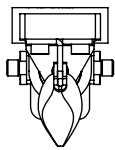
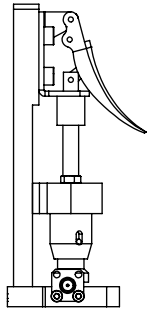
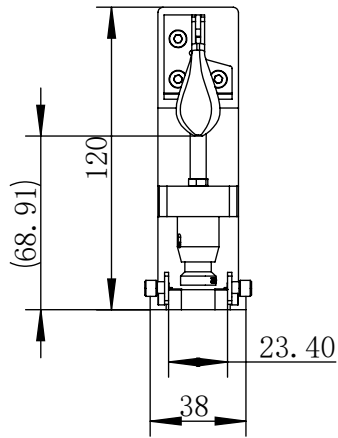

项目号	零件号	说明	数量
1	tff-00190-01	Test Fixture-01	1
2	TFF-00012-01	Fixed Block	1
3	TFF-00002-02	Guide Block	1
4	TFF-00002-05	Pressure Head Fixing Seat	1
5	TFF-00079-02	Pressure Head	1
6	DOW-00002	DOWEL $\Phi 2.0 \times 16$	1
7	SPR-00002	SPRING	1
8	SCR-00002	Screw 内六角圆柱头 M4X20	1
9	NUT-00001	M4 Nut	2
10	TAS-00088	GH-301-AM	1
11	SCR-00004	Screw 内六角圆柱头 M4X8	3
12	PCB-00105	PCB	2
13	con-00012	CONNECTOR SMK-F	2
14	SCR-00008	M2.5X6内六角螺丝	4
15	SCR-00005	Screw 内六角圆柱头 M3x12	2
16	SCR-00023	Screw 内六角圆柱头 M3x8	2

PART NAME: <b>测试夹具</b>		Designed: ZC.Wu	2024/7/16	<b>DAPU</b>
DRAWING NO. : <b>tff-00190</b>		Checked:		
DESCRIPTION: <b>TEST FIXTURE</b>		Approval:		TOLERANCES ON
		The first angle projection: $\text{---}$		DECIMALS
		Sheet 1 of 1		ANGLES
		Scale: 1:1	Unit: mm	.x $\pm 0.10$
				.xx $\pm 0.05$
				.xxx $\pm 0.02$
				$\pm 0.5^\circ$