

Customer Code:

# DATASHEET

DAPU P/N: CM66K-D129-10.00MHz-BD

Customer P/N: \_\_\_\_\_

DAPU			Customer Approval
Drew	Audited	Approved	Stamp, please! Thanks!
Date: 2024.01.29			

**Guangdong Dapu Telecom Technology Co., Ltd**

Building 5, No.24, Industrial East Road, Songshanhu Park, Dongguan, Guangdong, P.R. China

TEL: 0086-0769-88010888 FAX: 0086-0769-81800098





## Table of Content

1. GENERAL DESCRIPTION.....	4
2. PIN DEFINITION .....	5
3. ELECTRICAL PARAMETERS.....	5
4. PERFORMANCE.....	6
5. UART .....	7
6. CONTROL AND STATUS PINS .....	7
7. ENVIRONMENTAL CONDITIONS .....	8
8. TYPICAL APPLICATION.....	8
9. MECHANICAL STRUCTURE (MM).....	9
10. WAVE SOLDERING CURVE(ROHS) .....	10
11. PACKAGE (MM) .....	10



## 1. General Description

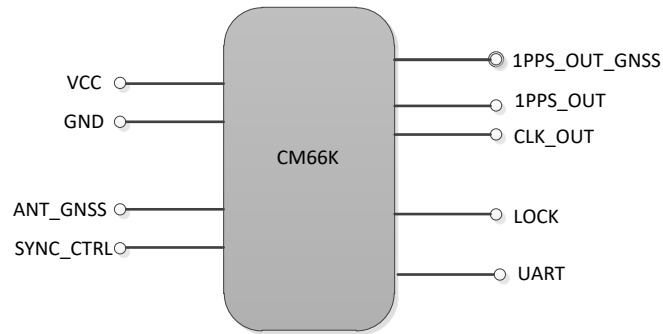

**Figure 1 CM66K**

Figure 1 is the basic diagram of CM66K. CM66K is a high-performance clock module designed to provide precise frequency and phase synchronizing with internal time reference for telecom and other applications.

### Key features:

- **Reference:** GNSS receiver
- **Temperature Stability:**  $\pm 0.2$ ppb;
- **Holdover:**  $\pm 20\mu\text{s}/8\text{h}$  @  $\Delta T = \pm 5^\circ\text{C}$ ;
- **Clocks Output:** 2\*1PPS output and 1\*10MHz output;
- **Serial Interface:** 1\*UART for TOD and management;
- **Mechanical Size:** 60mm\*60mm\*13mm.



## 2. Pin Definition

**Table 1 Pin Definition**

Pin group	Pin#	Pin Name	Type	Description
Supply Voltage	4, 9, 11, 13	GND	GND	Ground
	12	VCC	PWR	Power Supply
Control and Status Pins	8	SYNC_CT RL	I	Synchronizing Procedure Control
	5	LOCK	O	Lock Status
UART	6	RXD0	I	Asynchronous Serial Data Output/Input. 9600-N-8-1
	7	TXD0	O	
GNSS	10	1PPS_OUT	O	1PPSOutput from the internal GNSS receiver.
	SMA-KE	ANT	I	GNSS ANT signal input
Output Clocks	3	1PPS_OUT	O	1PPSOutput
	2	CLK_OUT	O	10.00MHz Output
Reserve	1, 14	NC		Not connected.

## 3. Electrical Parameters

**Table 2 Electrical Parameters**

Parameter	Symbol	Minimum	Typical	Maximum	Units
<b>LVC MOS Input</b>					
High Level Input Voltage	$V_{IH}$	2.7			V
Low Level Input Voltage	$V_{IL}$			0.4	V
<b>LVC MOS Output</b>					
High Level Output Voltage	$V_{OH}$	2.7			V
Low Level Output Voltage	$V_{OL}$			0.4	V



## 4. Performance

**Table 3 Performance**

Item	Parameter	Minimum	Typical	Maximum	Units	Test Condition
Internal Receiver Characteristics	Number of Channels			50		
	Frequency Band	BDS B1: (1561.098MHZ)				
	Tracking Code					C/A Code
	Tracking Capability			12		12 Satellites
	Sensitivity			-159		dBm
			-144		dBm	Acquisition
Clock Output	Nominal Frequency	10.00			MHz	Synchronizing with GNSS1PPS output.
	Duty Cycle	45	50	55	%	Load 15pF
	Frequency vs. Temperature	-0.2		+0.2	$\times 10^{-9}$	V <sub>cc</sub> =5.0V; O <sub>load</sub> =15pF; T <sub>A</sub> varies from -40°C to 85°C, temperature slope less than °C per minute.
	Accuracy	-1		+1	$\times 10^{-12}$	24 hours average value when locked to 1PPS.
	Short-term Stability	-0.02		+0.02	$\times 10^{-9}$	V <sub>cc</sub> =5.0V; T <sub>A</sub> =25°C; 1s; no EMI\EMC or other interference.
	Daily Aging	-0.2		+0.2	$\times 10^{-9}$	V <sub>cc</sub> =5.0V; T <sub>A</sub> =25°C. FREE RUN condition and after 30 days of operation.
	Yearly Aging	-0.01		+0.01	$\times 10^{-6}$	
	Phase Noise			-118	-113	dBc/Hz
			-138	-133	100Hz	
			-148	-143	1KHz	
			-150	-145	10KHz	
			-150	-145	100KHz	



			-150	-150		1MHz
1 PPS Output	Pulse Width		100		ms	
	Accuracy	-20		+20	ns	Synchronizing with 1PPS reference. Mean is 0, and standard deviation is 20ns. After locking, monitor 24 hours.
	8 hours holdover	-20		+20	$\mu$ s	$\Delta T = \pm 5^{\circ}\text{C}$ , 8 hours holdover after turn on 7days and GPS lock 3days. Temperature variable speed less than $1^{\circ}\text{C}$ per minute
Supply Voltage	Supply Voltage	4.75	5.0	5.25	V	
	Warm Up Current			2000	mA	During Warm-up
	Steady Current			1000	mA	During steady state operation @25°C
	AC Ripple			50	mV pk-pk	10Hz to 1MHz

## 5. UART

UART interfaces are used for management and TOD, which has a fixed baud rate (9600) using 1 stop bit and no parity. It is a LVTTTL-compatible port and needs an external translator to work with other signal types (such as RS-232C or RS-485).

## 6. Control and Status Pins

CM66K is a clock module which synchronizes the local clock to reference such as 1 PPS retrieving from GNSS. CM66K will work normally performing synchronizing algorithm when the SYNC\_CTRL pin is driven high. It also could be force to work in free-run or holdover status when the SYNC\_CTRL pin is driven low.

The LOCK pin indicates the lock status of CM66K. High level indicates the module is locked to GNSS reference. When the module never is locked to reference after power up, the status of module is free-run, the LOCK pin outputs low. When the GNSS signal is lost, the status of module is holdover, the LOCK pin also output low.



## 7. Environmental Conditions

Table 4 Environmental Conditions

Parameter	Conditions	
Operating Temperature	-40°C to 85°C	
Storage Temperature	-55°C to 105°C	
Storage Humidity	30%~80%	
ESD Level	Human Body Model, class2: 2000V to 4000V; ANSI/ESDA/JEDEC JS-001-2010.	
	Machine Model, class B: 200V to 400V; JEDEC JESD22-A115C.	
Moisture Sensitivity Level	Not Humidity Sensitive.	
Vibration	Test Condition: 0.75mm ;acceleration:10g;10Hz~500Hz, one cycle per 30 min, test 2 hour. (3 times for each 3 directions X ,Y , Z), IEC 68-2-06 Test Fc.	
Shock	50g; 11ms; half sine wave (3 times for each 3 directions X,Y,Z),IEC 68-2-27 Test Ea/Severity 50A.	
Relative Humidity	20%~70%	Full Package Storage
Temperature	-10°C~35°C	

## 8. Typical Application

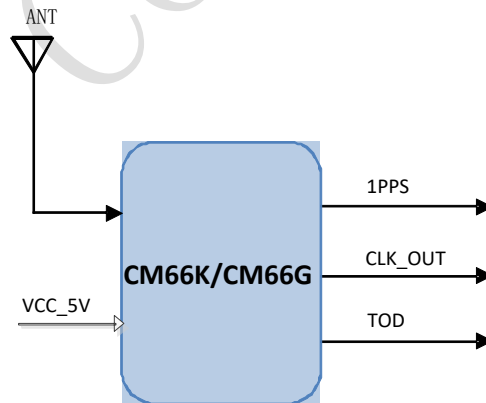

Figure 2 Typical application

GNSS Receiver is embedded in CM66K.





## 9. Mechanical Structure (mm)

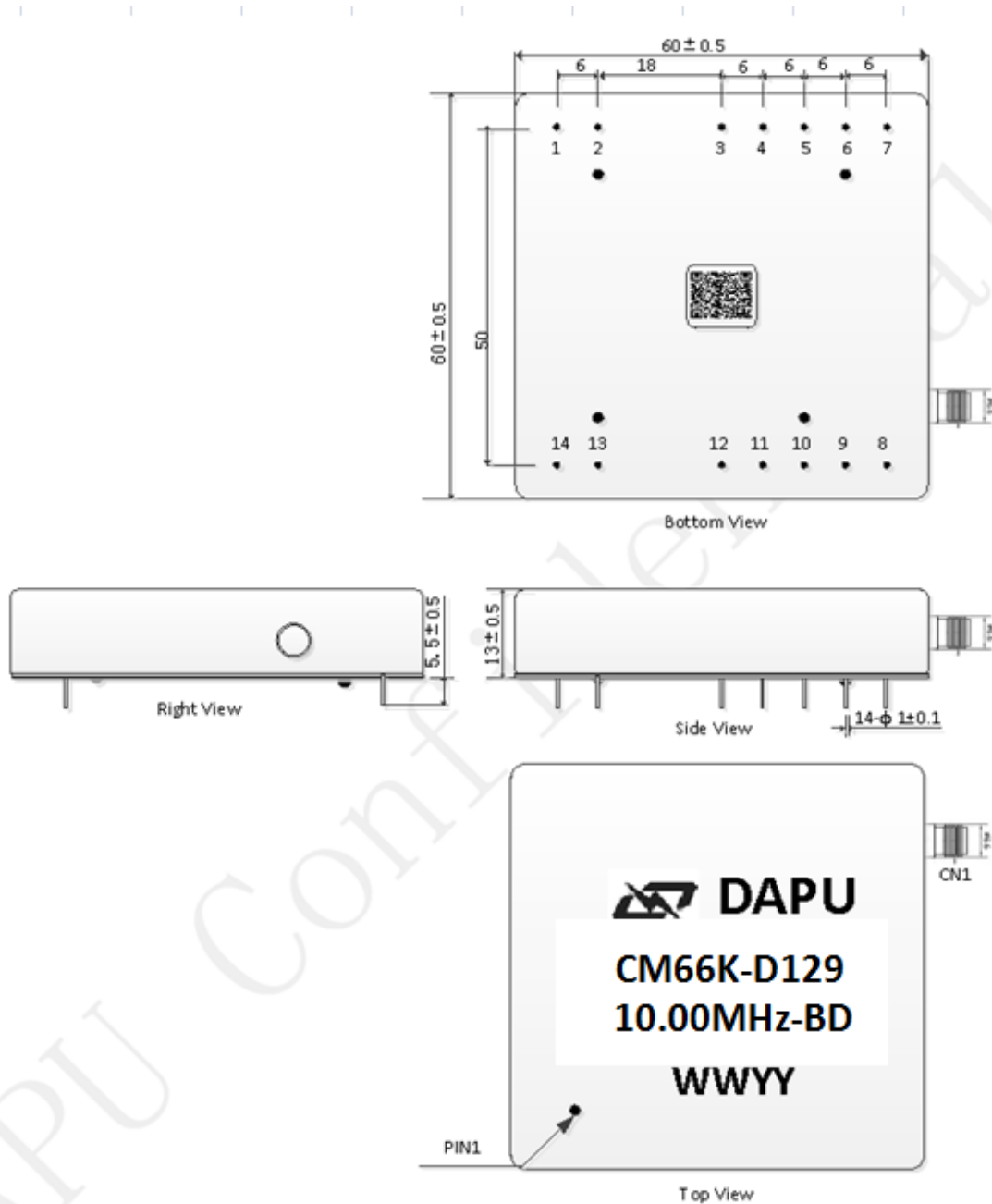

Figure 3 Mechanical structure

**Note1:** Tolerance  $\pm 0.2$ mm without mark.

**Note2:** WW represents Week.

YY represents Year.

**Note3:** Referential Weight  $82 \pm 10$ g



### 10. Wave Soldering Curve(RoHS)

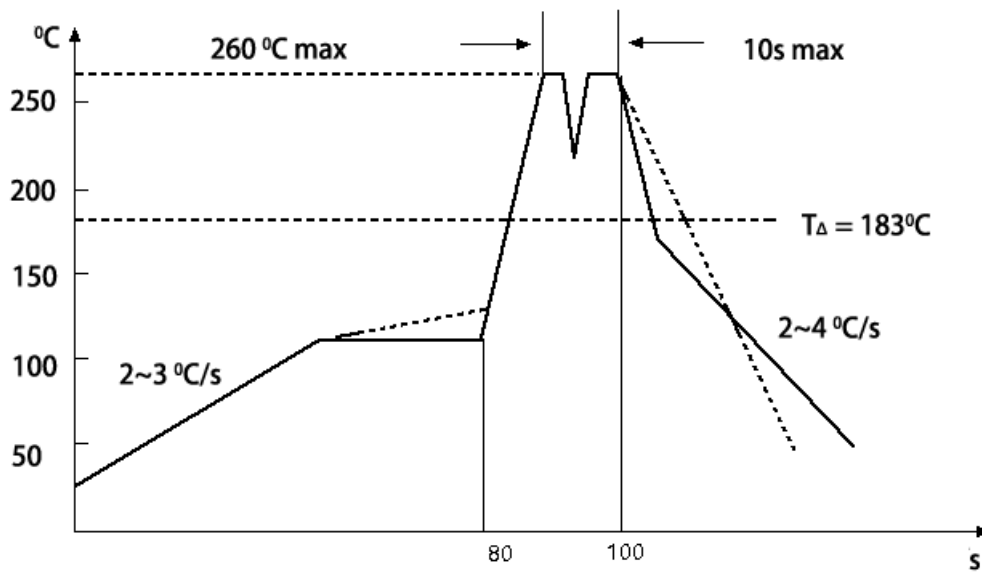

Figure 4 Wave soldering curve

### 11. Package (mm)

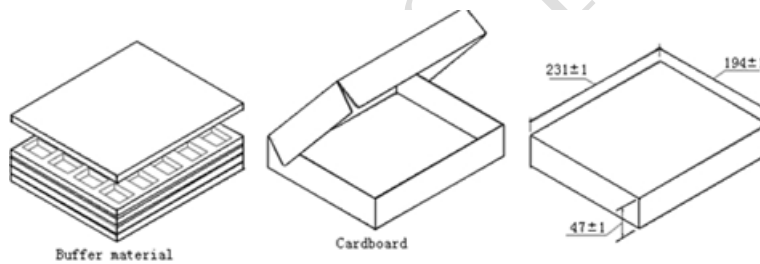

Figure 5 Package