

RoHS COMPLIANT

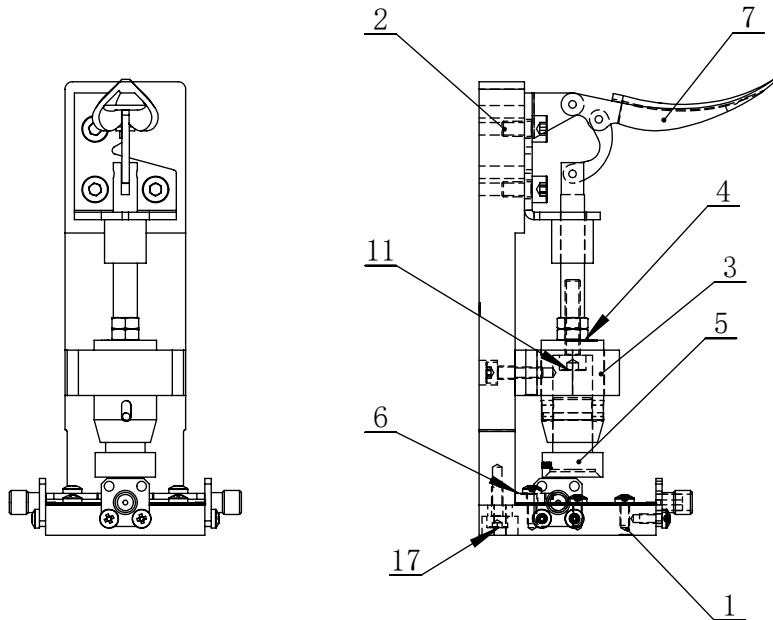

REVISIONS				
REV.	ECN NO.	DESCRIPTION	DATE	REVISOR
A		Producing release	2022/9/2	ZC.Wu

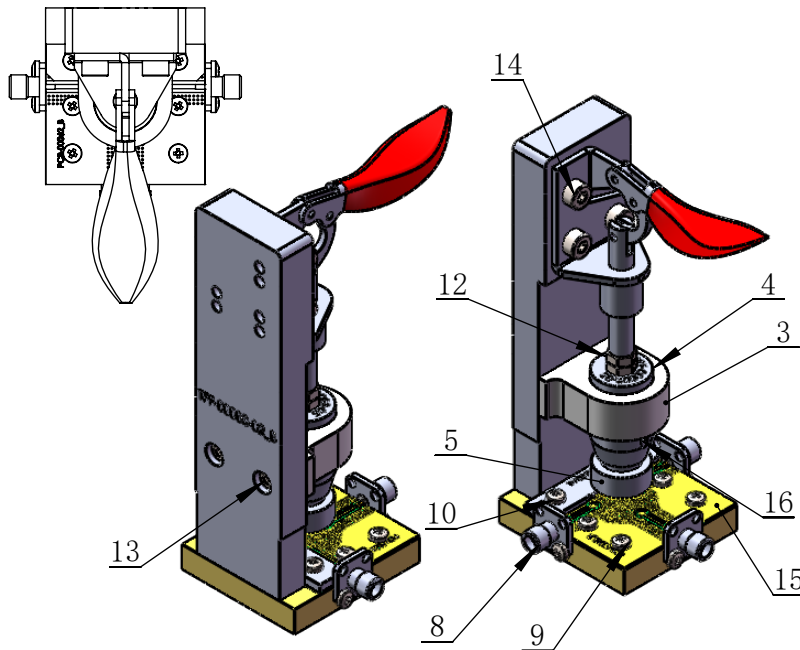

注：4和5之间内置弹簧
SPR-00002(线径1.4x外径10x长度15)

项目号	零件号	说明	数量
1	TFF-00088-01	Test Block	1
2	TFF-00003-02	Fixed Block	1
3	TFF-00002-02	Guide Block	1
4	TFF-00002-05	Pressure Head Fixing Seat	1
5	TFF-00017-03	Pressure Head	1
6	TFF-00088-02	Limited Bolck	1
7	tas-00088	GH-301-AM	1
8	CON-00001	CONNECTOR SMA-F	3
9	SCR-00001	SCREW 十字盘头 M2.5X6	10
10	SCR-00003	Screw 十字盘头 M2.5X8	2
11	SCR-00002	Screw 内六角圆柱头 M4X20	1
12	NUT-00001	M4 Nut	2
13	SCR-00005	Screw 内六角圆柱头 M3x12	2
14	SCR-00004	Screw 内六角圆柱头 M4X8	3
15	PCB-00062	PCB	1
16	DOW-00002	DOWEL $\Phi 2.0 \times 16$	1
17	SCR-00023	Screw 内六角圆柱头 M3x8	2



PART NAME: $\Phi 15.5$ ($\Phi 14$) 测试夹具	Designed:	ZC. Wu	
	Checked:		
DRAWING NO. : TFF-00088	Approval:		TOLERANCES ON
	The first angle projection: 		DECIMALS
DESCRIPTION: TEST FIXTURE	Sheet 1 of 1		ANGLES
	Scale:	Unit:	±0.1 ·x ±0.1 ·xx ±0.05 ·xxx ±0.02
	1:1	mm	