

Travelling Merchant: _____

DATASHEET

Standard: DPAM24M00002

Plot			The Label
Drew	Audited	Approved	Stamp, please! Thanks!
Date: 2023.09.26			

Guangdong Dapu Telecom Technology Co.,Ltd

Building 5, No.24, Industrial Road East, Songshanhu Park, Dongguan, Guangdong, P.R. China

TEL: 0086-0769-88010888 FAX: 0086-0769-81800098



1、 Electrical Parameters

MODEL: DPAM24M00002							
No.	Parameters	SYM.	Electrical Spec.				Notes
			Min.	Typ.	Max.	Units	
1	Nominal Frequency	FL	24.000			MHz	
2	Mode of Vibration	-	Fundamental			-	
3	Load Capacitance	CL	12			pF	
4	Frequency Tolerance	-	-10	-	+10	$\times 10^{-6}$	At 25°C± 2°C
5	Frequency Stability	-	-20	-	+20	$\times 10^{-6}$	TA=25°C
7	Aging	-	-2	-	+2	$\times 10^{-6}$	First Year
8	Drive Level	DL	1	10	100	μ W	
9	Effective Resistance Rr	Rr	-	-	40	Ω	
10	Shunt Capacitance C0	C0	-	-	2	pF	
11	Insulation Resistance	-	500	-	-	M Ω	At DC 100V
12	Operating Temperature		-20	~	+70	°C	
13	Storage Temperature Range	-	-55	~	+125	°C	
14	Moisture Sensitivity Level	Level 1.					

2、 Mechanical Structure(mm)

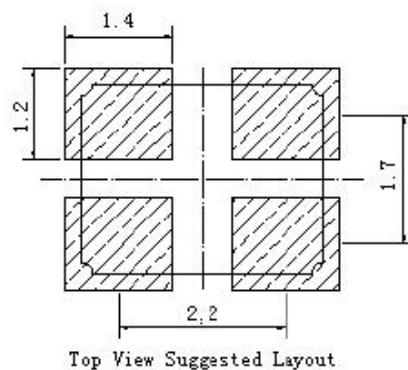
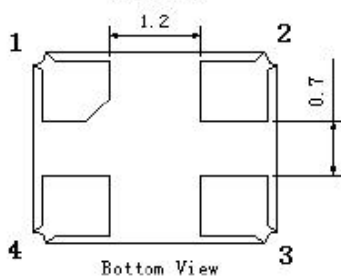
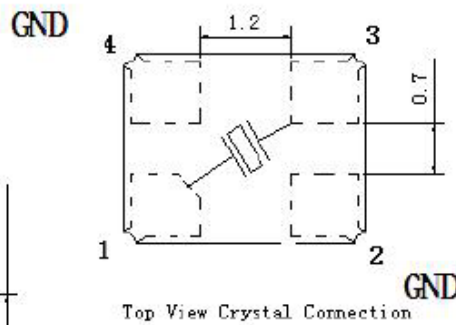
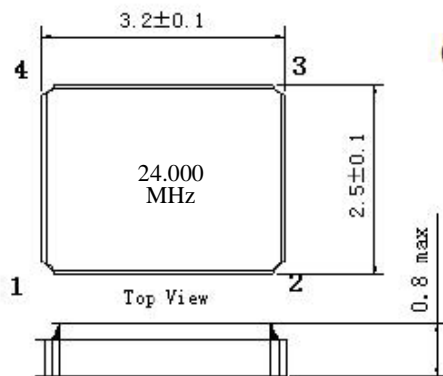

Pin 1	Xtal
Pin 2	GND
Pin 3	Xtal
Pin 4	GND



3、 Reflow Soldering Curve (RoHS)

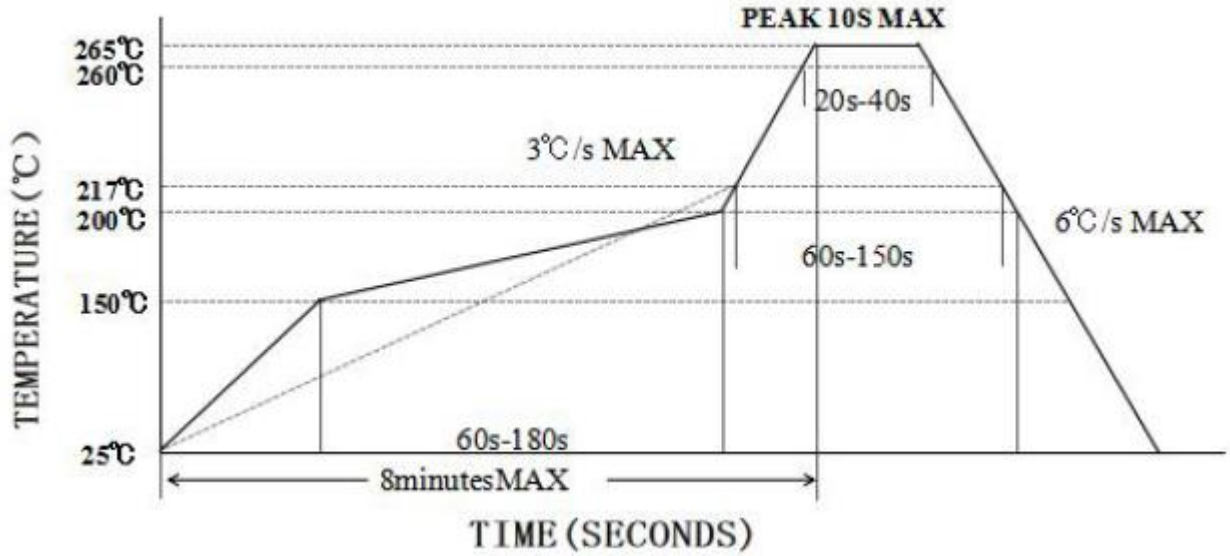

4、 Packing(mm)

