

CUSTOMER: _____

DATASHEET

PRODUCT TYPE: _____ DPTC2016 _____

DAPU P/N: T2016 C-A579-26.00MHz

Plot			The Label
Drew	Audited	Approved	Stamp, please! Thanks!
Jianhua LIN	William	Allen	
Date: 2023.05.26			

Guangdong Dapu Telecom Technology Co.,Ltd

Building 5, No.24, Industrial East Road, Songshanhu Park, Dongguan, Guangdong, P.R. China

TEL: 0086-0769-88010888 FAX: 0086-0769-81800098



1. Electrical Parameters

MODEL: T2016 C-A579-26.00MHz						
Item	Parameters	Specifications				Test Condition
		Min.	Typ.	Max.	Unit	
Output	Nominal Frequency	26			MHz	
	Output Waveform	Clipped Sine Wave				
	Output Level	0.8		1.2	Vp-p	
	Spurious Suppression			-9	dBc	
	Output Load	10KΩ//10pF				
Frequency Stabilities	Frequency Tolerance	-1.5		1.5	ppm	@25±2°C, after 2 times reflow soldering, Ref. to nominal frequency
	vs. Temperature	-0.5		0.5	ppm	T _A = -40°C ~ 85°C, VCC=1.8V, Ref. to f = (fmax-fmin)/2
	vs. Supply Voltage	-0.1		0.1	ppm	VCC = 1.8V ± 5% @ TA=25°C
	vs. Load	-0.1		0.1	ppm	Load = (10KΩ//10pF) ± 10%, VCC=1.8V @ TA=25°C
	Aging Tolerance	-1		1	ppm	@T _A =25°C, Year
	Jitter			8.5	ps	10Hz-1MHz
	Frequency Slope	-0.1		0.1	ppm/°C	T _A varied from -40°C to 85°C
Power Supply	Current consumption			2	mA	@TA=25°C, VCC=1.8V, Load=10KΩ//10pF.
	Start up Time			2	ms	More than 90% of final output voltage
	Supply Voltage	1.7	1.8	1.9	V	
SSB Phase Noise	Phase Noise@25±2°C		-85	-80	dBc/Hz	10Hz
			-116	-111		100Hz
			-144	-140		1KHz
			-155	-151		10KHz
			-160	-156		100KHz
Frequency drift rate(after DC power applied)				5	ppb/s	From 6s onwards
Environmental Conditions	Operable Temperature	-40		85	°C	
	Storage Temperature	-55		125	°C	
	ESD Level	Human Body Model,class2: 3000V; ANSI/ESDA/JEDEC JS-001-2010.				



		Machine Model, class B: 200V; JEDEC JESD22-A115C.
	Moisture Sensitivity Level	Level 1.
	Vibration	Test Condition: 0.75mm ;acceleration:10g;10Hz~2000Hz, one cycle per 30 min, test 2 hour. (3 times for each 3 directions X ,Y , Z) .IEC 68-2-06 Test Fc.
	Shock	100g; 6ms; half sine wave (3 times for each 3 directions X ,Y , Z),IEC 68-2-27 Test Ea/Severity 50A.
Full Package Storage	Relative humidity (%)	20%~70%
	Temperature (°C)	-10~35°C

2. Mechanical Structure(mm)

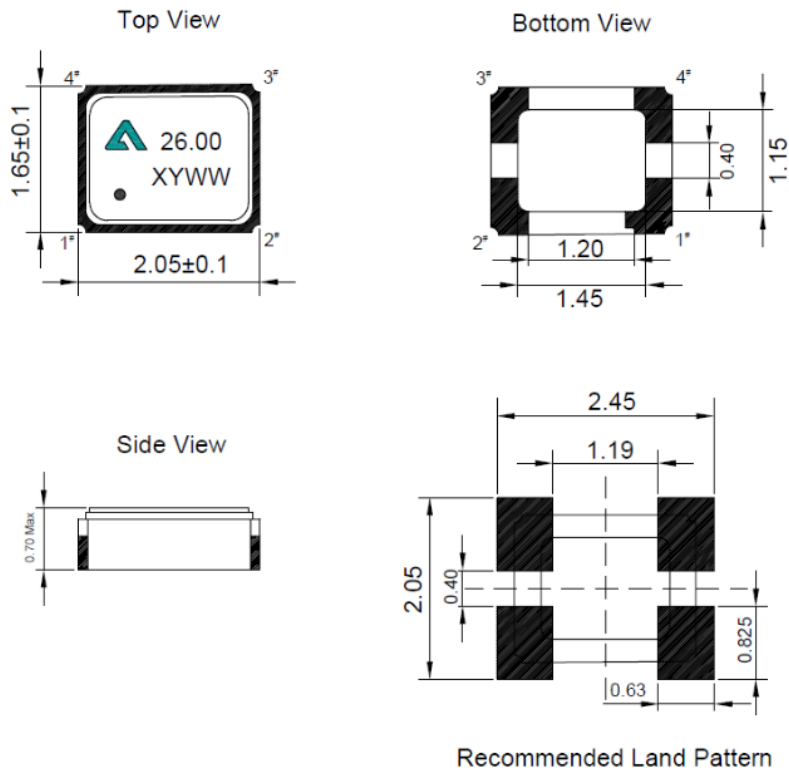

PIN NAME	CONNECTION
PIN1	NC
PIN2	GND
PIN3	OUTPUT
PIN4	VCC

Note1: N/C is not connected



3. Marking Information

<p>26.00: Frequency 26.00Mhz X: Lot No. Y: Year WW: Week ● : Pin1 Index</p>	
--	--

4. Test Circuit

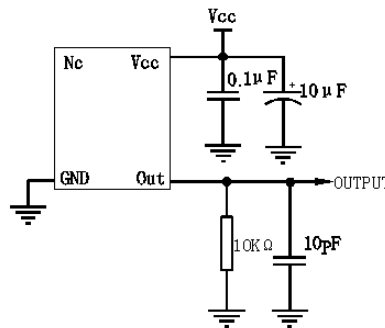

5. Reflow Soldering Curve (RoHS)

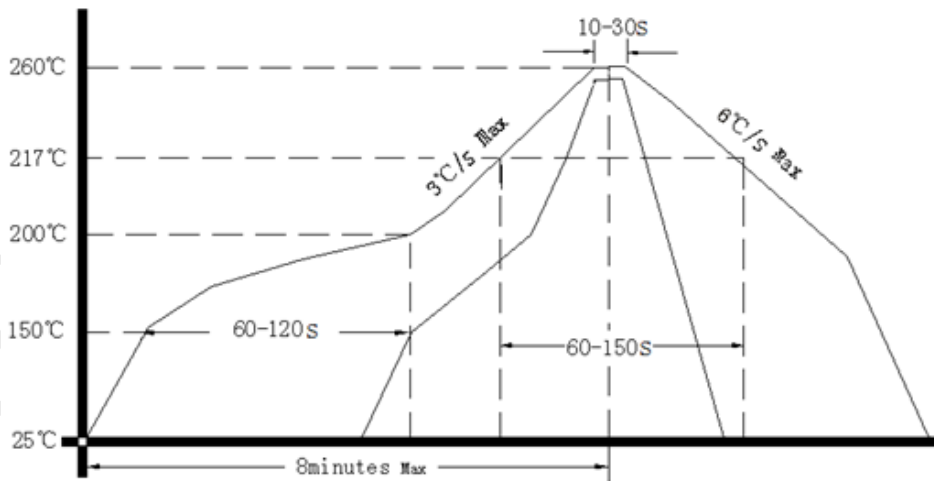



6. Packing Information

1) Carrier tape and taping reel sizes (Unit: mm)

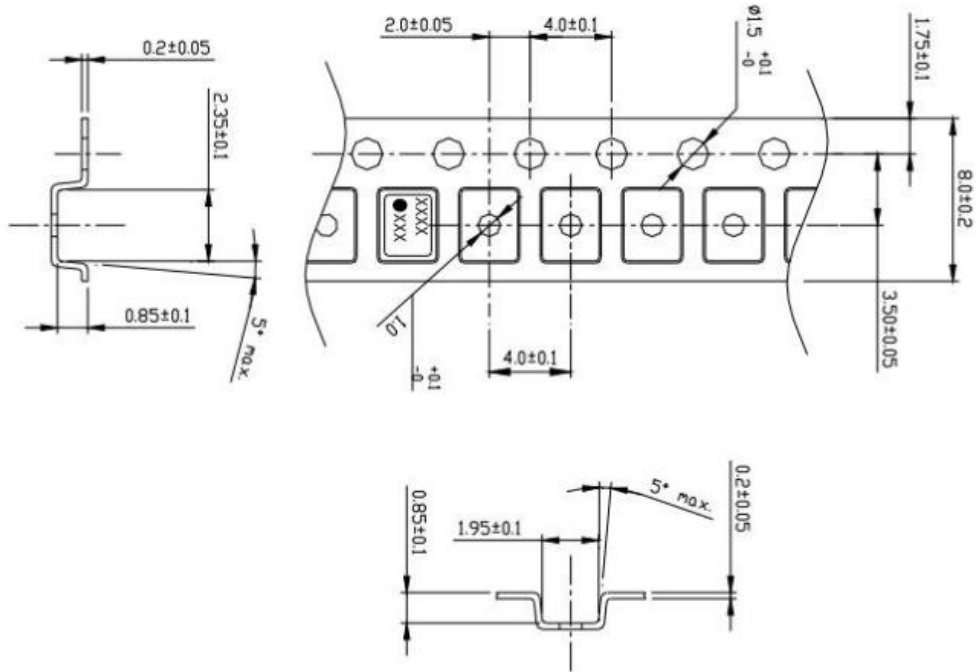

1. Clearance of an embossing tape, and a product unit: mm

Direction	Pocket size	TCXO size	Clearance
L	2.35±0.10	2.00±0.15	0.35±0.25
W	1.95±0.10	1.60±0.15	0.35±0.25
H	0.85±0.05	0.70±0.10	0.15±0.15

2. Quality : Polystyrene (Conductivity)

3. Tensile strength of an embossing tape : more than 14N

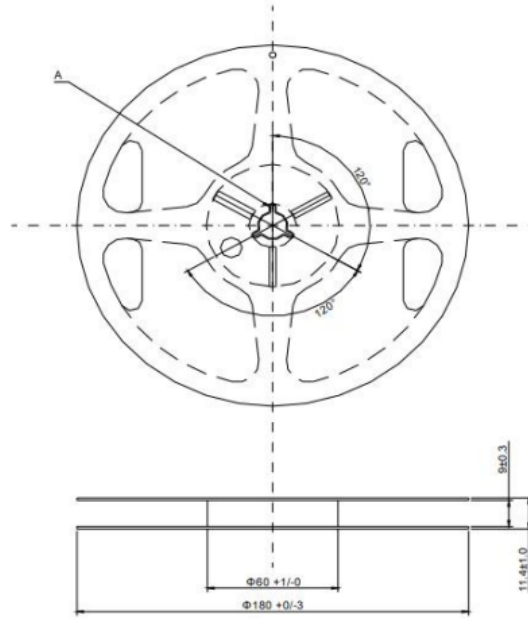

Material:Polystyrene (Conductivity)
unit:mm

Section A

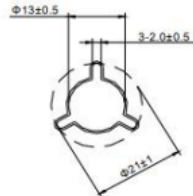

DAPU Cont.