



1、Electrical Parameters

MODEL: O11F-2604-10.00MHz						
Item	Description	Parameters			Unit	Test Condition
		Min.	Typ.	Max.		
Output	Nominal Frequency	10.00			MHz	f_n
	Output Waveform	LVTTL				
	Output Low Voltage	0		0.4	V	$V_{cc}=3.3V, CL = 15pF$
	Output High Voltage	2.4		3.6	V	
	Duty Cycle	45	50	55	%	
	Rise / Fall Time		2	6	ns	$CL = 15pF, 10\% \sim 90\%$
	Load	14.25		15.75	pF	
Frequency Stabilities	Reflow	-0.1		+0.1	$\times 10^{-6}$	After 2 hours of reflow relaxation, refer to the frequency change before reflow
	Initial Frequency Tolerance	-2		+2	$\times 10^{-6}$	Measurement referenced to frequency Observed with $T_A=25^\circ C, V_{cc}=3.3V$, and after 5 minutes of operation.
	Aging Tolerance Per Day	-3		+3	$\times 10^{-9}$	After 7 days in operation.
	Over All Frequency Stability	-3		+3	$\times 10^{-6}$	Referenced to f_n including 20 years aging.
	Short-Term Stability: Allan Variance		5	10	$\times 10^{-12}$	Temperature stability, no EMI\EMC or other interference, test after power for 1 hour ref. to $25^\circ C; 1s$.
	Frequency Tolerance vs. Operating Temperature Range	-3		+3	$\times 10^{-9}$	T_A varied from $-40^\circ C$ to $95^\circ C$, measurement referenced to frequency observed with $f_{ref}=(f_{max}+f_{min})/2, V_{cc}=3.3V, O_{load}=15pF$, temperature variable speed less than $2^\circ C$ per minute.
	Hysteresis			0.3	$\times 10^{-9}$	
Power Supply	Supply Voltage range	3.13	3.3	3.47	Vdc	
	AC Ripple and Noise			50	mVp-p	10Hz to 1MHz
	Supply Voltage (V_{cc}) to GND	-0.3		5.5	V	Pin 3 and 6
	Digital Input Voltage (SDA, SCL) to GND	-0.3		5.5	V	Pin 2 and 7
	Current Consumption			400	mA	Steady state at $+25^\circ C$ in still air
				800	mA	
Warm-Up Time $\Delta f/f$			<10	sec	To be within $\pm 200ppm$ of the nominal frequency. At operating temperature range	
			<5	min	To be within ± 40 ppb of the frequency after 1h of operation	



Jitter	Jitter			500	fs	Bandwidth 12KHz to 20MHz RMS
Phase Noise	Phase Noise			<-80	dBc/Hz	1Hz
				<-115		10Hz
				<-138		100Hz
				<-150		1KHz
				<-155		10KHz
				<-155		100KHz
				<-155		≥1MHz
Spurious Level During Vibration	Spurious at offset from f ₀ during vibration at 2g Vibration conditions: (sinus wave) Vibration in three perpendicular directions. 10 to 200Hz.			<-55	dBc	≤ 200 Hz
				<-75		≤ 500 Hz
				<-95		> 500 Hz
Environmental Conditions	Operating Temperature Range	-40		+95	°C	Ambient temperature
	Non Destruct Operating Temperature Range	-40		+95	°C	
	Storage Temperature Range	-40		+95	°C	
	Relative Humidity during storage	0		95	%	
	Relative Humidity	0		95	%	Over operating temperature range
	Air flow			0	m/s	@-40°C ~ +85°C
	Temperature Rate Of Change	0		1	°C/minute	
	Moisture Sensitivity Level	Level 2.				
	ESD Level	Human Body Model, class2: 2000V to 4000V; ANSI/ESDA/JEDEC JS-001-2010.				
		Machine Model, class B: 200V to 400V; JEDEC JESD22-A115C				
Vibration	Test Condition: 0.75mm ;acceleration:10g;10Hz~500Hz, one cycle per 30 min, test 2 hour. (3 times for each 3 directions X ,Y , Z), IEC 68-2-06 Test Fc.					
Shock	1000g; 11ms; half sine wave (3 times for each 3 directions X ,Y , Z),IEC 68-2-27 Test Ea/Severity 50A.					



2、 Temperature Sensor Output Characteristics

The product shall provide I2C temperature output information to detect the temperature change at the bottom of OCXO.
Temperature sensor details refer to SGMICRO SGM459.

Product Device Address: 1001 000

3、 EEPROM Interface (SDA, SCL) Characteristics

Parameter	Min.	Typ.	Max.	Units	Condition
DC Electrical Characteristics					
High Level Input Voltage (Vih)	2.4		3.6	Vdc	SDA and SCL
Low Level Input Voltage (Vil)	-0.6		0.8	Vdc	SDA and SCL
Input Leakage Current, SCL	-10		+10	μA	Vpin<0.4V or Vpin>0.9Vcc
Input Leakage Current, SDA	-230		+30	μA	Vpin<0.4V or Vpin>0.9Vcc (Note 1)
Low Level Output Voltage, SDA (Vol)	0		0.4	V	Ipin = 6mA
Electrical Characteristics (Note 2)					
SCL Clock Frequency	0		100	KHz	
Communication (Note 2, 3)					
Product Device Address	1010 011X			X denotes read/write bit	
Note: 1) SDA requires a 20kΩ pull-up resistor to Vcc. 2) Product is to communicate via industry standard I ² C™ bus timing. I ² C™ is a Phillips Semiconductor registered trademark. 3) For manufacturing purposes vendors sometimes use other I ² C™ addresses than Product Device Address above, therefore it is strongly recommended to have the OCXO on a separate I ² C™ bus in the application.					



4、EEPROM Data Format

The oscillator shall be provided with the following information in the EEPROM. After the data is written the EEPROM should be made read-only.

EEPROM Data Format			
Data format is internally organized with 256 words of 1 byte each			
Header Bits 0-255	Memory Location	Description	Format
0-7	00h	EEPROM data version number [Version=4]	HEX
8-135	01h-10h	Serial number (Note 1)	ASCII
136-223	11-1Bh	Ericsson part number [RTL205***/1]	ASCII
224-255	1Ch-1Fh	Set to [][][][] [4 spaces]	ASCII
Data Bits 256-1007	Bytes	Description	
256-319	20h-27h	Initial frequency (f ₁) (At 40°C rounded to 0.001Hz)	32.32 unsigned
320-383	28h-2Fh	Temp coefficient A ₃	32.32 2's complement
384-447	30h-37h	Temp coefficient A ₂	32.32 2's complement
448-511	38h-3Fh	Temp coefficient A ₁	32.32 2's complement
512-575	40h-47h	Temp coefficient A ₀	32.32 2's complement
576-639	48h-4Fh	T _{max}	32.32 2's complement
640-703	50h-57h	T _{min}	32.32 2's complement
704-783	58h-61h	Date of calibration [YYYY-MM-DD]	ASCII/ISO-8601
784-1007	62h-7Dh	Reserved [set to all zeros]	HEX
Check Sum Bits 1008-1023	Bytes	Description	
1008-1015	7Eh	Most significant byte of the check sum (Note 4)	HEX
1016-1023	7Fh	Least significant byte of the check sum (Note 4)	HEX
Supplier Use Bits		Description	
1024-1983	80h-F7h	Supplier Product ID [O11F-2604-10.00MHz]	
Supplier Function Bits 1984-2039	Bytes	Description	
1984-1999	F8h-F9h	Reserved for Supplier	
2000-2007	Fah	Reserved for Supplier	
2008-2023	FBh-FCh	Reserved for Supplier	
2024-2039	FDh-FFh	Reserved for Supplier	

1) Serial number must be same serial number that is stated on Product package. Fill out with spaces (0x20) after serial number.
2) N/A
3) Check sum is a 16-bit word that will be calculated as a byte by byte unsigned summation of only the header and data bits.
4) Ericsson product number should be written and stored without spaces and in CAPITAL letters



5、 Frequency Versus Temperature

Manufacturer shall characterize each oscillator's frequency output (in ppb) over the operational temperature range. While performing this characterization, Supplier shall perform a least squares curve fit to this frequency versus temperature.

The curve fit shall be a cubic polynomial of the form:

$$A_3T^3 + A_2T^2 + AT + A_0 = \frac{f(T) - f(1)}{f(1)} \quad \text{Equation 1}$$

The residual error shall be such that:

$$\left| \frac{f(T) - f(1)}{f(1)} - \sum_{i=0}^3 A_i T^i \right| < 0.3ppb \quad \text{Equation 2}$$

A_x: Temperature compensation parameters (see register list)

T: This parameter is read by Temperature sensor

f(T): measured frequency.

f(1): Parameter variables associated with the reference Temperature (40°C)

After this calculation is performed, the coefficients, A_i shall be saved to the EEPROM as specified in section 4.

The oscillator shall be able to meet this performance over any 30°C window within the operating temperature range and at a operating temperature range -40°C~95°C. Manufacturer understands that these coefficients represent a curve that is a measurement of the frequency versus temperature characteristic of the oscillator. The extent to which the results of Equation 2 are repeatable (+/- a vertical shift) is an indication of the thermal hysteresis or "retrace" of the characteristic.



6、 Mechanical Structure(mm)

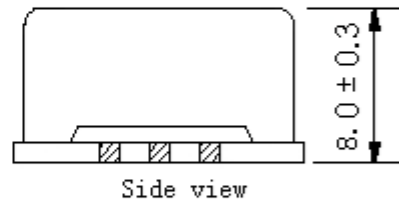
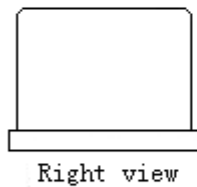
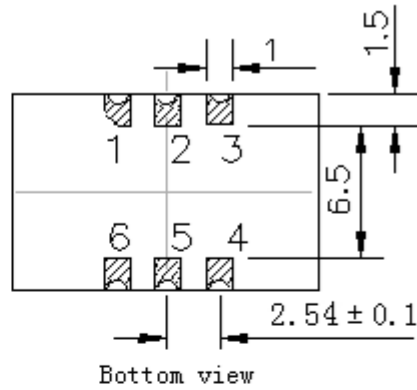
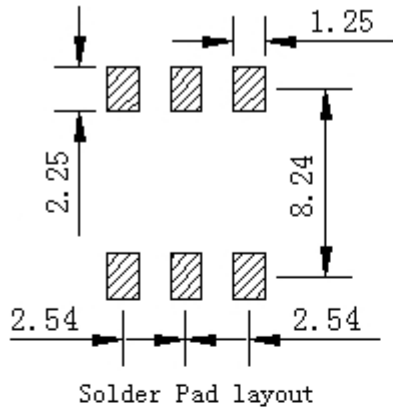

PIN FUNCTION

PIN	FUNCTION
1	SDA
2	SCL
3	GND
4	RF Output
5	Not Connect
6	Supply Voltage



Note1: Tolerance ± 0.1 mm without mark

Note2: The first two xx representative: week
After two xx representative: year



7、 Test Circuit

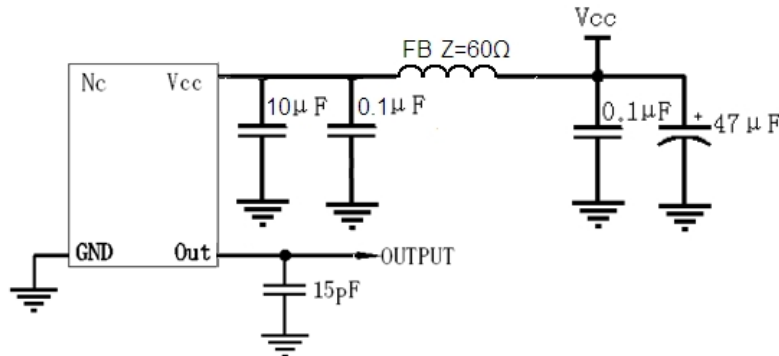

8、 Reflow Soldering Curve (RoHS)

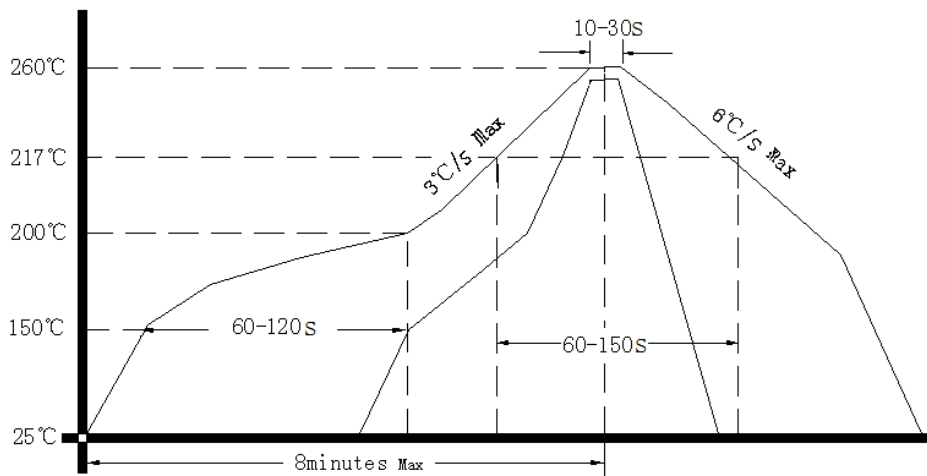

Additional requirement:

The oscillator shall withstand a temperature of +255°C measured at the solder joints and on the top surface of the package.

The oscillator shall also withstand at least 90 seconds above +220°C.

Passing through reflow upside down is not supported

9、 Package (mm)

