

RoHS COMPLIANT

REVISIONS				
REV.	ECN NO.	DESCRIPTION	DATE	REVISOR
A	-	Producing release	2021/9/16	
B	0588	增加焊盘拉力要求	2022/10/11	ZC.Wu

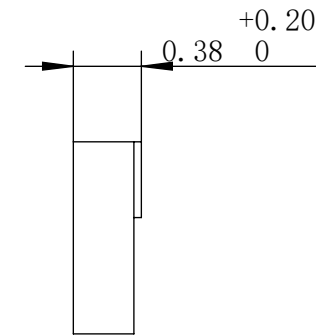

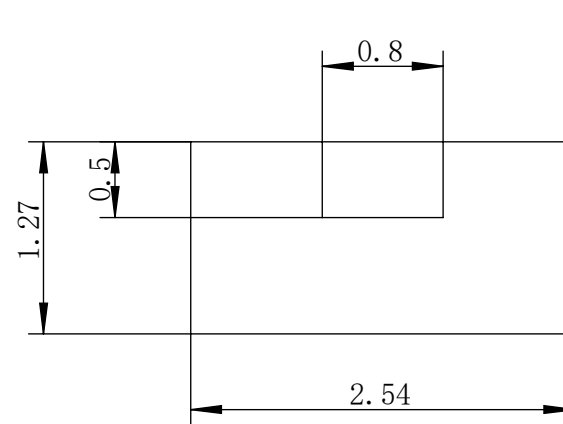

特性:

1. 标称阻值: $50\ \Omega \pm 5\%$
 2. 额定功率: 10W
 3. 频率: DC-8.5GHz
 4. 驻波比: $\leq 1.3:1$
 5. 温度范围: $-55\sim+150\text{ }^{\circ}\text{C}$
 6. 温度系数: $\pm 300\text{ppm}/^{\circ}\text{C}$
 7. 基片材料: ALN
- 禹龙通型号: RFR50N-10CT27006A

拉力要求:

电阻焊盘单位面积 (mm^2) 上所能承受的拉力 $\geq 1.01\text{kgf}$

PART NAME: 10W 负载片	Designed:	ZC. Wu		
	Checked:			
DRAWING NO. : TER-00011	Approval:		TOLERANCES ON	
	The first angle projection: 			DECIMALS
DESCRIPTION: Termination	Sheet 1 of 1		± 0.25	$\pm 0.5^{\circ}$
	Scale: 1:1	Unit: mm		