

RoHS COMPLIANT

注：4和3之间内置弹簧SPR-00001
(线径1.6x外径10x长度15)

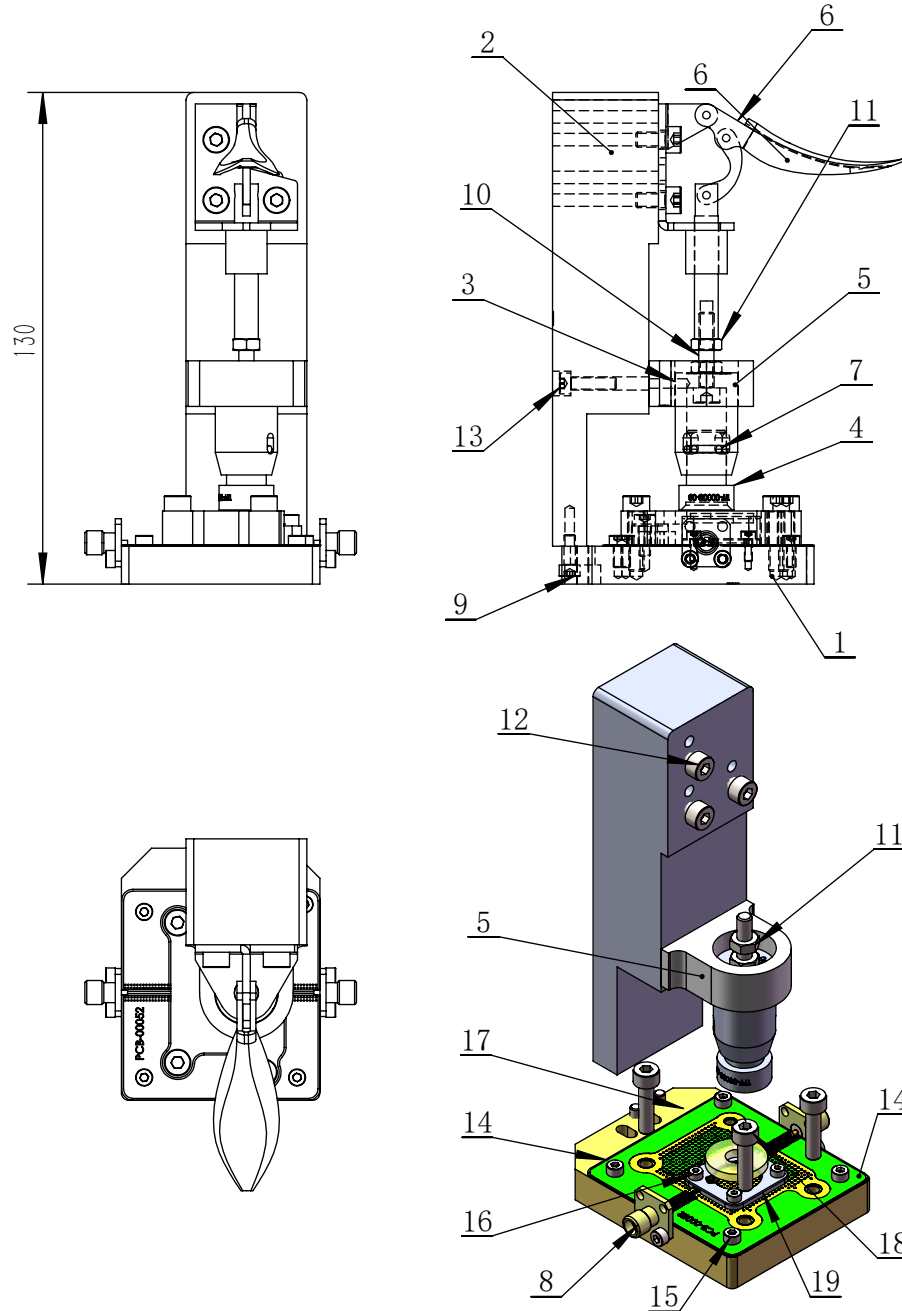

REVISIONS				
REV.	ECN NO.	DESCRIPTION	DATE	REVISOR
A	-	Producing release	2022/9/15	

项目号	零件号	说明	数量
1	TFF-00068-01	Test Block	1
2	TFF-00068-02	Fixed Block	1
3	TFF-00002-05	Pressure Head Fixing Seat	1
4	TFF-00003-03	Pressure Head	1
5	TFF-00002-02	Guide Block	1
6	TAS-00088	GH-301-AM	1
7	DOW-00002	DOWEL Φ2.0 x 16	1
8	CON-00002	CONNECTOR SMA-F	2
9	SCR-00023	Screw 内六角圆柱头 M3x8	3
10	SCR-00002	Screw 内六角圆柱头 M4X20	1
11	NUT-00001	M4 Nut	2
12	SCR-00004	Screw 内六角圆柱头 M4X8	3
13	SCR-00005	Screw 内六角圆柱头 M3x12	2
14	PCB-00052	PCB	1
15	SCR-00008	M2. 5X6内六角螺丝	8
16	SCR-00012	M2X6内六角螺丝	4
17	TFF-00068-07	COVER	1
18	SCR-00022	ISO 4762 M4 x 12 - 20N	3
19	TFF-00068-03	Limited Block	1
20	TFF-00068-08	TEST FIXTURE-08	1

PART NAME: 测试夹具	Designed:	ZC. Wu		
	Drawing:	ZZ. Zhu		
DRAWING NO. : tff-00068	Approval:		TOLERANCES ON	
	The first angle projection:		DECIMALS	ANGLES
DESCRIPTION: TEST FIXTURE	Sheet 1 of 1		±0.20	±0.5°
	Scale: 1:1	Unit: mm	A4	