

RoHS COMPLIANT

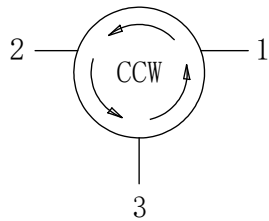
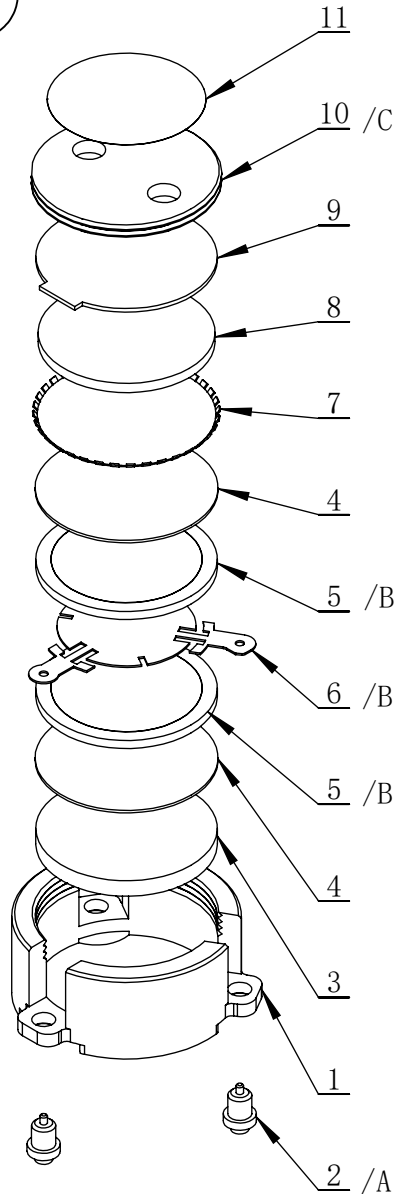

CCW ORIENTATION

NOTES:

Ensure MAGNET is orientated correctly when stacking.

REVISIONS				
REV.	ECN NO.	DESCRIPTION	DATE	REVISOR
A	/	Producting release	2021/12/16	
B	0395	去掉一片PPF-00127, 新增一片PPF-00065	2022/3/25	
C	0451	HMF-00010改为HMF-00038	2022/5/25	ZC.Wu

FIXTURE	
TFF-00089	TEST FIXTURE
-	THRU FIXTURE
PAF-00075	PILL ASSEMBLY FIXTURE
AFF-00026	ASSEMBLY FIXTURE

PRODUCTION AUXILIARY MATERIALS		
Item	Part No.	Description
A	SPF-00001	SOLDER, SN96
B	GLU-00001	LOCTITE 382
C	GLU-00003	LOCTITE 480

项目号	零件号	说明	数量
1	HMF-00038	Housing	1
2	PFF-00009	Plastic Frame	3
3	MDF-00052	MAGNET DISC	1
4	PPF-00065	POLE PIECE	2
5	FDL-00268	FERRITE DISC	2
6	CCC-00314	CIRCUIT	1
7	GPF-00005	GROUND PLANE	1
8	MDF-00053	MAGNET DISC	1
9	TCF-00038	TEMP COMP	1
10	CMF-00014	COVER	1
11	LAB-00008-03	Φ10.5 LABEL	1

DRAWING NO. :
AD-DP0730C

SURFACE TREATMENT:
SILVER PLATING

DESCRIPTION:
SMT CIRCULATOR

Designed: Jie.Jiang

Checked:

Approval:

The first angle projection:

Sheet 1 of 1

Scale: 1:1

Unit: mm

TOLERANCES ON

DECIMALS	ANGLES
±0.20	±0.5°