

Travelling Merchant: _____

DATASHEET

Standard: DPAT10000001-SA

Plot			The Label
Drew	Audited	Approved	Stamp, please! Thanks!
Jack	David	William	
Date: 2022.11.07			

Guangdong Dapu Telecom Technology Co.,LTD

Building 5, No.24, Industrial East Road, Songshanhu Park, Dongguan, Guangdong, P.R. China

TEL: 0086-0769-88010888 FAX: 0086-0769-81800098



1. Electrical Parameters

MODEL: DPAT10000001-SA							
No.	Parameters	SYM.	Electrical Spec.				Notes
			Min.	Typ.	Max.	Units	
1	Nominal Frequency	FL	10.00			MHz	
2	Oscillation Mode	-	Fundamental			-	AT-CUT
3	Load Capacitance	CL	18			pF	
4	Frequency Tolerance	FL	-20		+20	$\times 10^{-6}$	25°C
5	Frequency Stabilities	TC	-30		+30	$\times 10^{-6}$	T _A =25°C
6	Resonant Resistance	RR			50	Ω	
7	Parasitic Attenuation	SPDB			-3	dB	F0±500KHz
8	Aging	-	-5		+5	$\times 10^{-6}$	First Year
9	Drive Level	DL		100		μ W	
10	Insulation Resistance	-	500	-	-	M Ω	At DC 100V
11	Shunt Capacitance	C0			7	pF	
12	Operating Temperature	-	-20		+70	°C	
13	Storage Temperature Range	-	-40		+105	°C	



2. Mechanical Structure(mm)

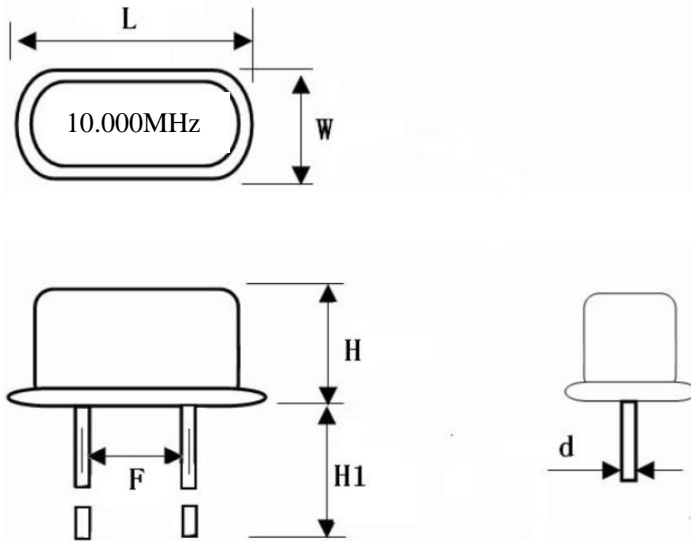

L	W	H	H1	F	d
10.8±0.5	4.4±0.3	3.38±0.3	12.9±0.5	4.88±0.2	0.45±0.05

3. Reflow Soldering Curve (RoHS)

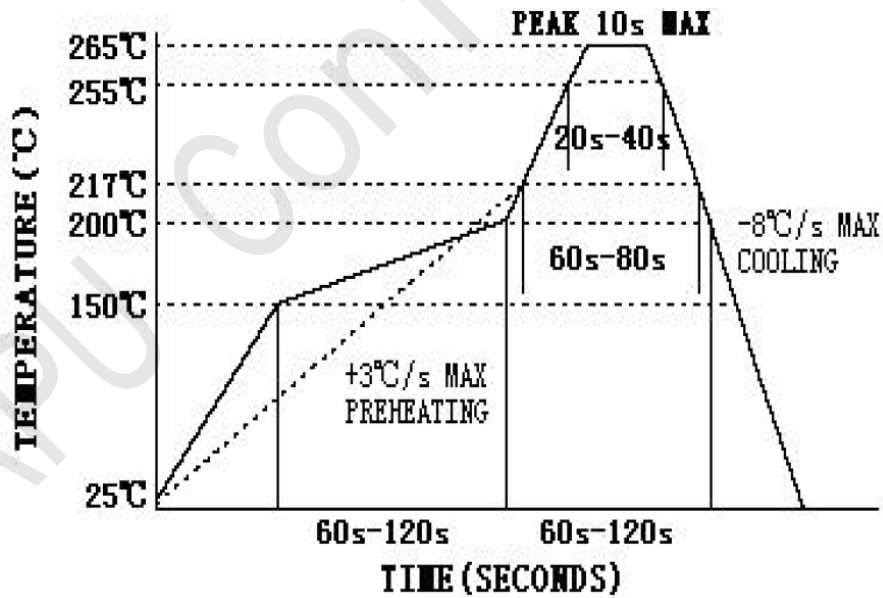



4. Package: Tape & Reel (mm)

1. Plastic bag packaging

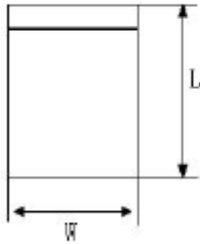

200pcs per package

2. Inner box

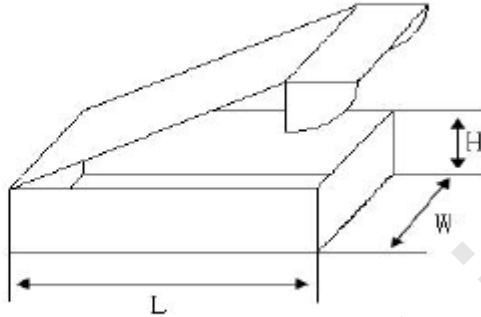

10 packs per box

3. Carton

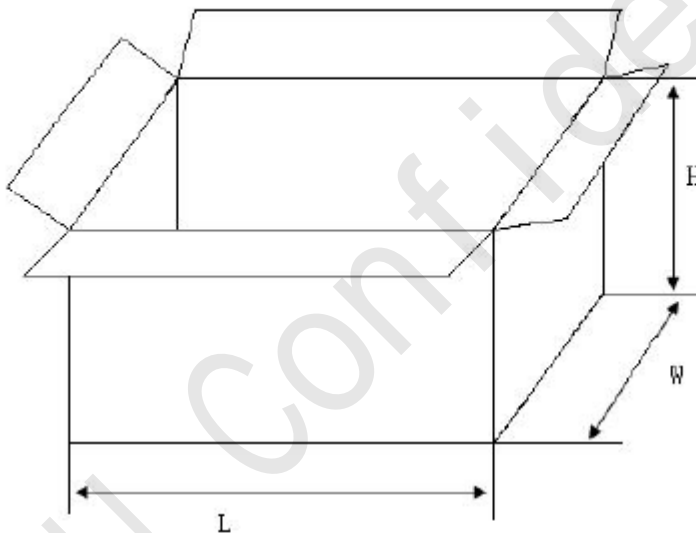

10 boxes per box

Size and Quantity

Number	Size (L*W*H)	Quantity
1	125*100	200pcs
2	190*146*70	2000pcs
3	410*345*252	20000pcs