

**RoHS COMPLIANT**

REVISIONS				
REV.	ECN NO.	DESCRIPTION	DATE	APPROVAL
A	/	Producing release	2021/11/15	

A

A-A



B

C

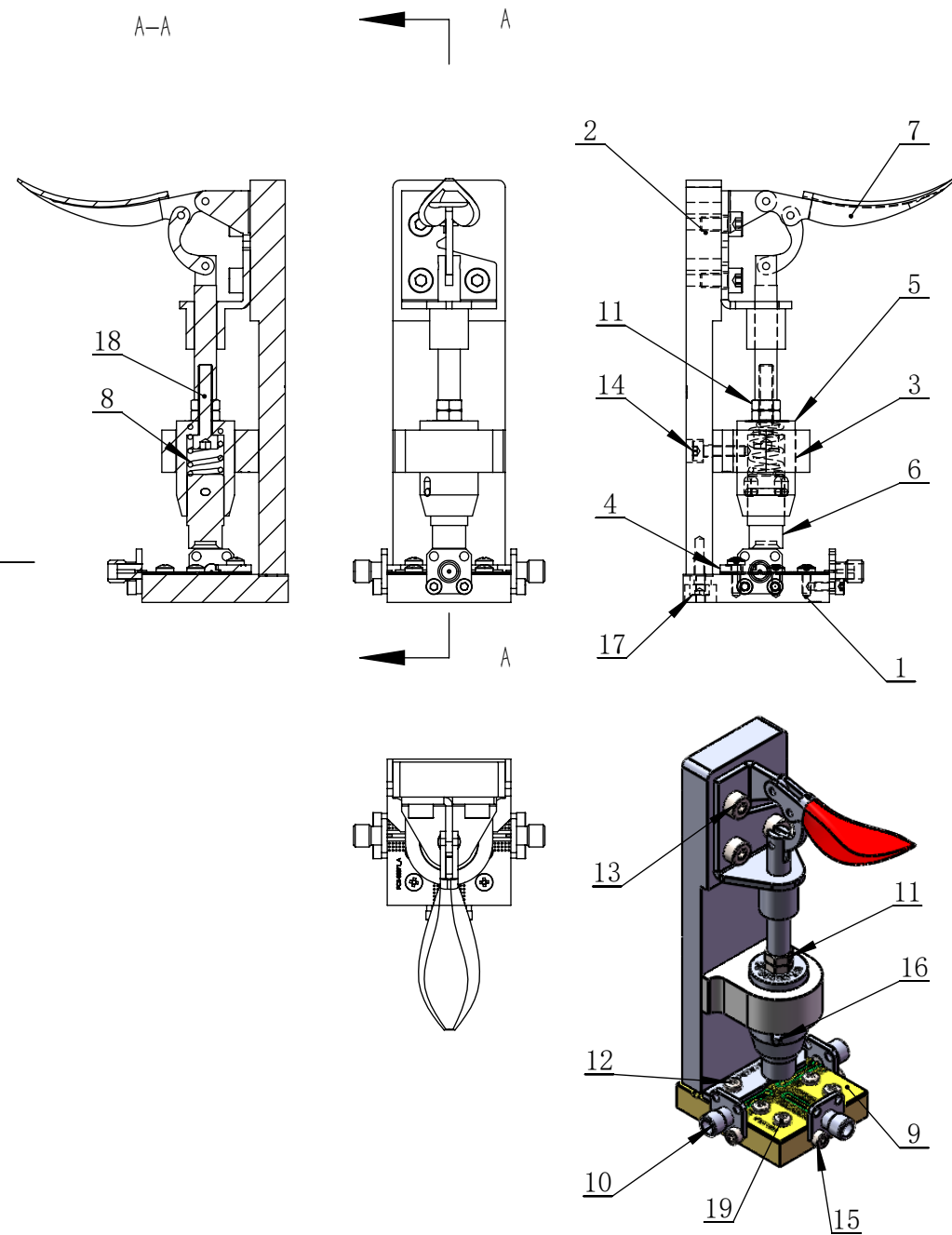
D



项目号	零件号	说明	数量
1	TFF-00103-01	Test Block	1
2	TFF-00012-01	Fixed Block	1
3	TFF-00002-02	Guide Block	1
4	TFF-00103-02	Limited Block	1
5	TFF-00002-05	Pressure Head Fixing Seat	1
6	TFF-00012-03	Pressure Head	1
7	TAS-00088	GH-301-AM	1
8	SPR-00002	SPRING	1
9	PCB-00071	PCB	1
10	con-00004	CONNECTOR SMA-F	3
11	NUT-00001	M4 Nut	2
12	SCR-00003	Screw 十字盘头 M2.5X8	2
13	SCR-00004	Screw 内六角圆柱头 M4X8	3
14	SCR-00005	Screw 内六角圆柱头 M3x12	2
15	SCR-00008	M2.5X6内六角螺丝	6
16	DOW-00002	DOWEL Φ2.0 x 16	1
17	SCR-00023	Screw 内六角圆柱头 M3x8	2
18	SCR-00002	Screw 内六角圆柱头 M4X20	1
19	SCR-00001	SCREW 十字盘头 M2.5X6	4

PART NAME: 7mm 测试夹具		Designed: ZC. Wu	
DRAWING NO.: TFF-00103		Checked:	
DESCRIPTION: TEST FIXTURE		Approval:	TOLERANCES ON
		The first angle projection: 	DECIMALS
		Sheet 1 of 1	ANGLES
		Scale: 1:1	.x ±0.10
		Unit: mm	.xx ±0.05
			.xxx ±0.02
			±0.5°