

Travelling Merchant: _____

DATASHEET

Standard: **T32-R513-25.00MHz**

P/N: **TC-0275**

Plot			The Label
Drew	Audited	Approved	Stamp, please! Thanks!
Date: 2022.03.23			

Guangdong Dapu Telecom Technology Co.,Ltd

Building 5, No.24, Industrial East Road, Songshanhu Park, Dongguan, Guangdong, P.R. China

TEL: 0086-0769-88010888 FAX: 0086-0769-81800098



Table of amendment

Version	Revision contents	Prepared by	Revised date
1.0	The first issued	<i>Amway</i>	2009.01.06
1.1	The “Mechanical Structure” changed	<i>Amway</i>	2022.03.23



1. Electrical Parameters

MODEL: T32-R513-25.00MHz						
Item	Description	Parameters			Unit	Test Condition
		Min.	Typ.	Max.		
Output	Frequency	25.00			MHz	
	Output Waveform	Clipped Sine Wave				
	V _{p-p}	0.8			V	
	Load	10KΩ//10pF				
Frequency Stabilities	Frequency Tolerance vs. Operating Temperature Range	-1		+1	× 10 ⁻⁶	T _A varied from -30°C to 75°C, measurement referenced to frequency observed with T _A =25°C, V _{cc} =3.3V, V _c =1.5V, O _{load} =10KΩ//10pF, temperature variable speed less than 2°C per minute.
	Nominal Frequency Tolerance	-1		+1	× 10 ⁻⁶	Measurement referenced to frequency observed with T _A =25°C, V _{cc} =3.3V, V _c =1.5V within 30 days after ex-works.
	Frequency Tolerance vs. Supply Voltage	-0.2		+0.2	× 10 ⁻⁶	measurement referenced to frequency observed T _A =25°C, V _{cc} varied from 3.13V to 3.47V, V _c =1.5V and O _{Load} =10KΩ//10pF.
	Frequency Tolerance vs. Load	-0.2		+0.2	× 10 ⁻⁶	5% load change measurement referenced to frequency observed with T _A =25°C, V _{cc} =3.3V, V _c =1.5V and O _{Load} =10KΩ//10pF.
	Aging Tolerance Per Day	-0.02		+0.02	× 10 ⁻⁶	T _A =25°C, V _{cc} =3.3V, V _c =1.5V and after 1h of operation.
	Aging Tolerance 1 Year	-1		+1	× 10 ⁻⁶	
Power Supply	Operating Current			3	mA	@25°C, V _{cc} =3.3V, V _c =1.5V, O _{Load} =10KΩ//10pF.
	Supply Voltage	3.13	3.3	3.47	V	
Voltage Control	Frequency tuning range	-15		-10	× 10 ⁻⁶	V _c = 0.5V. measurement referenced to V _c =1.5V.
		-1		+1	× 10 ⁻⁶	V _c =1.5V. measurement referenced to Exactly 25.00MHz.
		+10		+15	× 10 ⁻⁶	V _c =2.5V. measurement referenced to V _c =1.5V.
	Linearity			10	%	
	Slope	Positive				
	Input Impedance	100			KΩ	



Phase Noise	Phase Noise		-80	-75	dBc/Hz	10Hz
			-108	-103		100Hz
			-133	-128		1KHz
			-145	-140		10KHz
			-150	-145		100KHz
			-150	-145		1MHz
Environmental Conditions	Operable Temperature	-30		+75	°C	
	Storage Temperature	-55		+105	°C	
	ESD Level	Human Body Model, class2: 2000V to 4000V; ANSI/ESDA/JEDEC JS-001-2010.				
		Machine Model, class B: 200V to 400V; JEDEC JESD22-A115C.				
	Moisture Sensitivity Level	Level 2.				
	Vibration	Test Condition: 0.75mm ;acceleration:10g;10Hz~2000Hz, one cycle per 30 min, test 2 hour. (3 times for each 3 directions X , Y , Z) .IEC 68-2-06 Test Fc.				
Shock	100g; 6ms; half sine wave (3 times for each 3 directions X, Y, Z), IEC 68-2-27 Test Ea/Severity 50A.					



2. Mechanical Structure(mm)

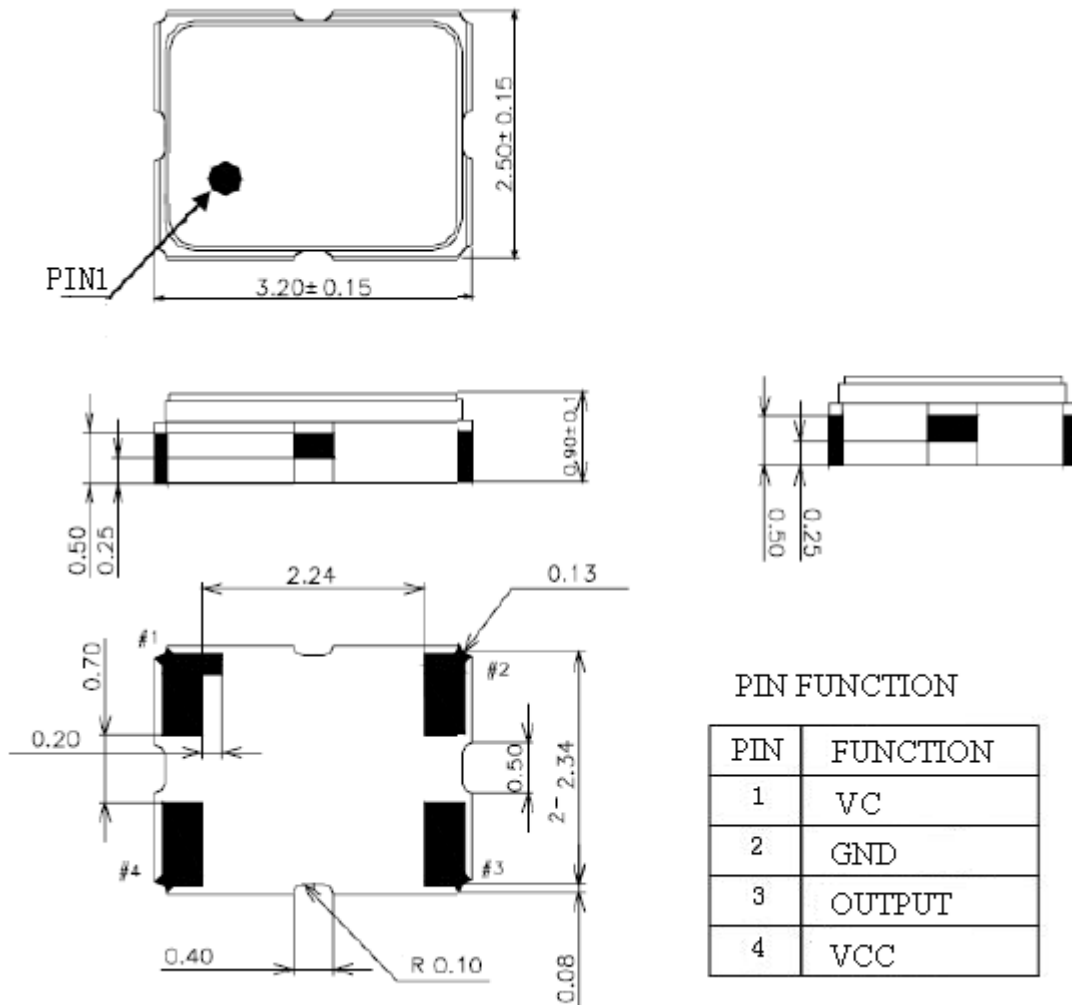

Note1: Tolerance ±0.1mm without mark

Note2: Referential Weight 0.1g

3. Test Circuit

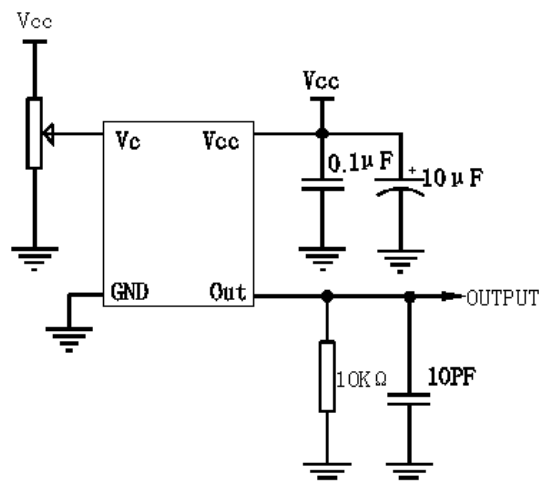



4. Reflow Soldering Curve (RoHS)

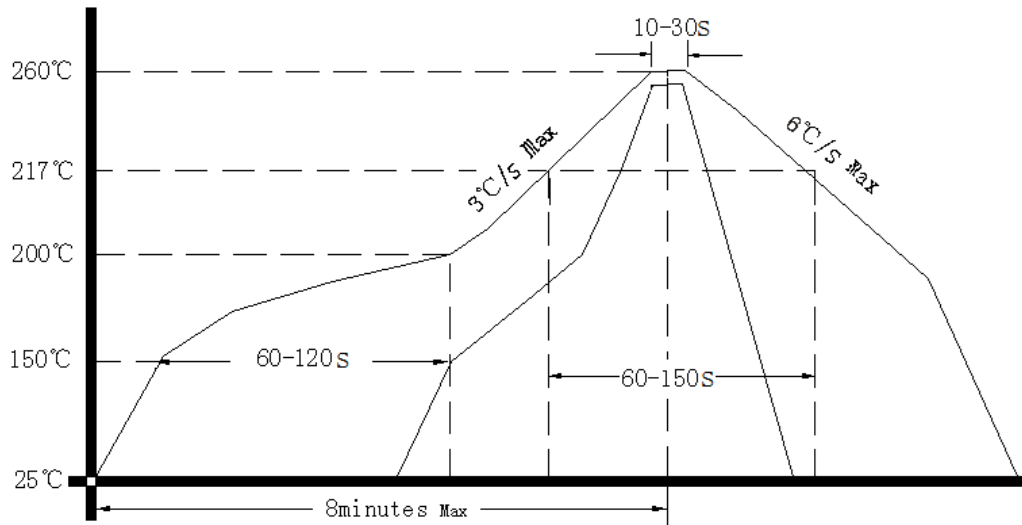

5. Package: Tape & Reel (mm)

