

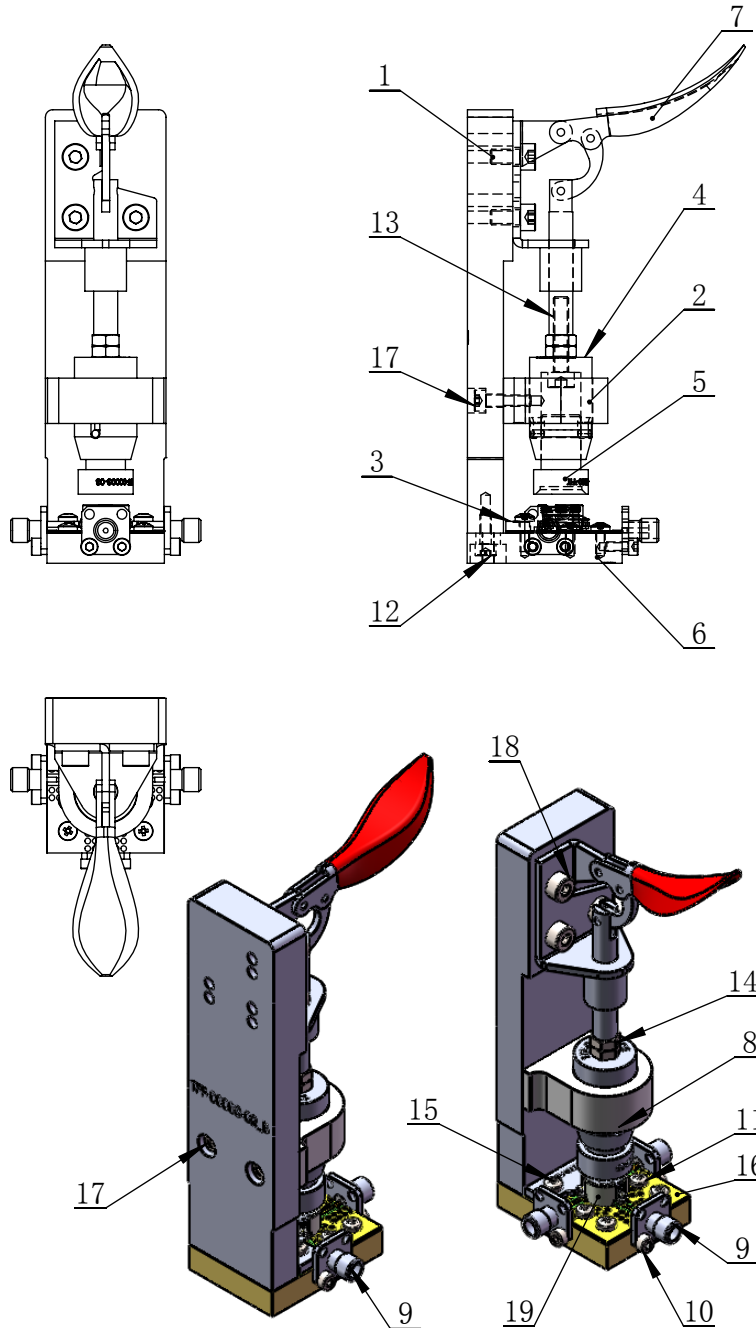

RoHS COMPLIANT



注：4和5之间内置弹簧 SPR-00001 (线径1.6x外径10x长度15)

项目号	零件号	说明	数量
1	TFF-00003-02	Fixed Block	1
2	TFF-00002-02	Guide Block	1
3	TFF-00003-04	Limited Bolck	1
4	TFF-00002-05	Pressure Head Fixing Seat	1
5	TFF-00003-03	Pressure Head	1
6	TFF-00003-01	Test Block	1
7	TAS-00088	GH-301-AM	1
8	DOW-00002	DOWEL $\Phi 2.0 \times 16$	1
9	CON-00001	CONNECTOR SMA-F	3
10	SCR-00008	M2.5X6内六角螺丝	6
11	SCR-00001	SCREW 十字盘头 M2.5X6	4
12	SCR-00023	Screw 内六角圆柱头 M3x8	2
13	SCR-00002	Screw 内六角圆柱头 M4X20	1
14	NUT-00001	M4 Nut	2
15	SCR-00003	Screw 十字盘头 M2.5X8	2
16	PCB-00004	PCB	1
17	SCR-00005	Screw 内六角圆柱头 M3x12	2
18	SCR-00004	Screw 内六角圆柱头 M4X8	3
19	PRODUCT	SMT $\Phi 12.5$ CIRCULATOR	1

PART NAME: 测试夹具	Designed:	ZC. Wu						
	Checked:							
DRAWING NO. : TFF-00003	Approval:		TOLERANCES ON					
	The first angle projection: 		<table border="1"> <tr> <td>DECIMALS</td> <td>ANGLES</td> </tr> <tr> <td>.x ± 0.10</td> <td rowspan="3">$\pm 0.5^\circ$</td> </tr> <tr> <td>.xx ± 0.05</td> </tr> <tr> <td>.xxx ± 0.02</td> </tr> </table>	DECIMALS	ANGLES	.x ± 0.10	$\pm 0.5^\circ$.xx ± 0.05
DECIMALS	ANGLES							
.x ± 0.10	$\pm 0.5^\circ$							
.xx ± 0.05								
.xxx ± 0.02								
DESCRIPTION: TEST FIXTURE	Sheet 1 of 1							
	Scale: 1:1	Unit: mm	-					