

Travelling Merchant: _____

DATASHEET

Standard: **O55F-Q369-10.00MHz**

P/N: _____

Plot			The Label
Drew	Audited	Approved	Stamp, please! Thanks!
Date: 2021.01.27			

Guangdong Dapu Telecom Technology Co.,Ltd

Bldg13-16,,N.Ind.Zone,SSL Industry Park, Dongguan City, Guangdong Province, China

TEL: 0086-0769-88010888 FAX: 0086-0769-81800098



Table of amendment

Version	Revision contents	Prepared by	Revised date
1.0	The first issued	<i>Amway</i>	2021.01.26
1.1	The "Rise / Fall Time" changed	<i>Amway</i>	2021.01.27



1、Electrical Parameters

MODEL: O55F-Q369-10.00MHZ						
Item	Description	Parameters			Unit	Test Condition
		Min.	Typ.	Max.		
Output	Frequency	10.00			MHz	
	Output Waveform	HCMOS				
	Output Low Voltage			0.4	V	$V_{cc}=13.0V, O_{load}=15pF$
	Output High Voltage	2.7			V	$V_{cc}=13.0V, O_{load}=15pF$
	Duty Cycle	45	50	55	%	@50%
	Rise / Fall Time (10%~90%)			3	ns	@25°C
	Load	15			pF	
Frequency Stabilities	Frequency Tolerance vs. Operating Temperature Range			+0.2	$\times 10^{-9}$	T_A varied from -40°C to 85°C, measurement referenced to frequency observed with $f_{ref} = (f_{max}-f_{min})/2f_0, V_{cc}=13.0V, O_{load}=15pF$. temperature variable speed less than 2°C per minute.
	Initial Frequency Tolerance	-0.05		+0.05	$\times 10^{-6}$	Measurement referenced to frequency observed with $T_A=25^\circ C, V_{cc}=13.0V$, and after 15 minutes of operation, within 30 days after ex-works.
	Frequency Tolerance vs. Supply Voltage	-0.2		+0.2	$\times 10^{-9}$	measurement referenced to frequency observed $T_A=25^\circ C, V_{cc}$ varied from 12.35V to 13.65V,, and $O_{Load}=15pF$.
	Frequency Tolerance vs. Load	-0.2		+0.2	$\times 10^{-9}$	5% load change measurement referenced to frequency observed with $T_A=25^\circ C, V_{cc}=12.0V$, and $O_{Load}=15pF$.
	Short-Term Stability : Allan Variance			0.005	$\times 10^{-9}$	Temperature stability, no EMI\EMC or other interference, test after power for 1hour ref. to 25°C; 1s.
	Aging Tolerance Per Day	-0.2		+0.2	$\times 10^{-9}$	V_{cc}, T_A constant measurement referenced to frequency observed with $T_A=25^\circ C, V_{cc}=13.0V$, and after 30 days of operation.
	Aging Tolerance 1 Year	-0.02		+0.02	$\times 10^{-6}$	
Power Supply	Supply Voltage	12.35	13	13.65	V	
	Current Consumption			300	mA	@25°C
	Current Consumption during warm up			700	mA	
	Refer Voltage Output		5		V	



Phase Noise	Phase Noise		-100	-90	dBc/Hz	1Hz
			-130	-120		10Hz
			-145	-135		100Hz
			-150	-145		1KHz
Environmental Conditions	Operable Temperature	-40		+85	°C	
	Storage Temperature	-55		+105	°C	
	ESD Level	Human Body Model, class2: 2000V to 4000V; ANSI/ESDA/JEDEC JS-001-2010.				
		Machine Model, class B: 200V to 400V; JEDEC JESD22-A115C.				
	Moisture Sensitivity Level	Not humidity sensitive.				
	Vibration	Test Condition: 0.75mm ;acceleration:10g;10Hz~500Hz, one cycle per 30 min, test 2 hour. (3 times for each 3 directions X , Y , Z), IEC 68-2-06 Test Fc.				
Shock	50g; 11ms; half sine wave (3 times for each 3 directions X , Y , Z),IEC 68-2-27 Test Ea/Severity 50A.					



2、 Mechanical Structure(mm)

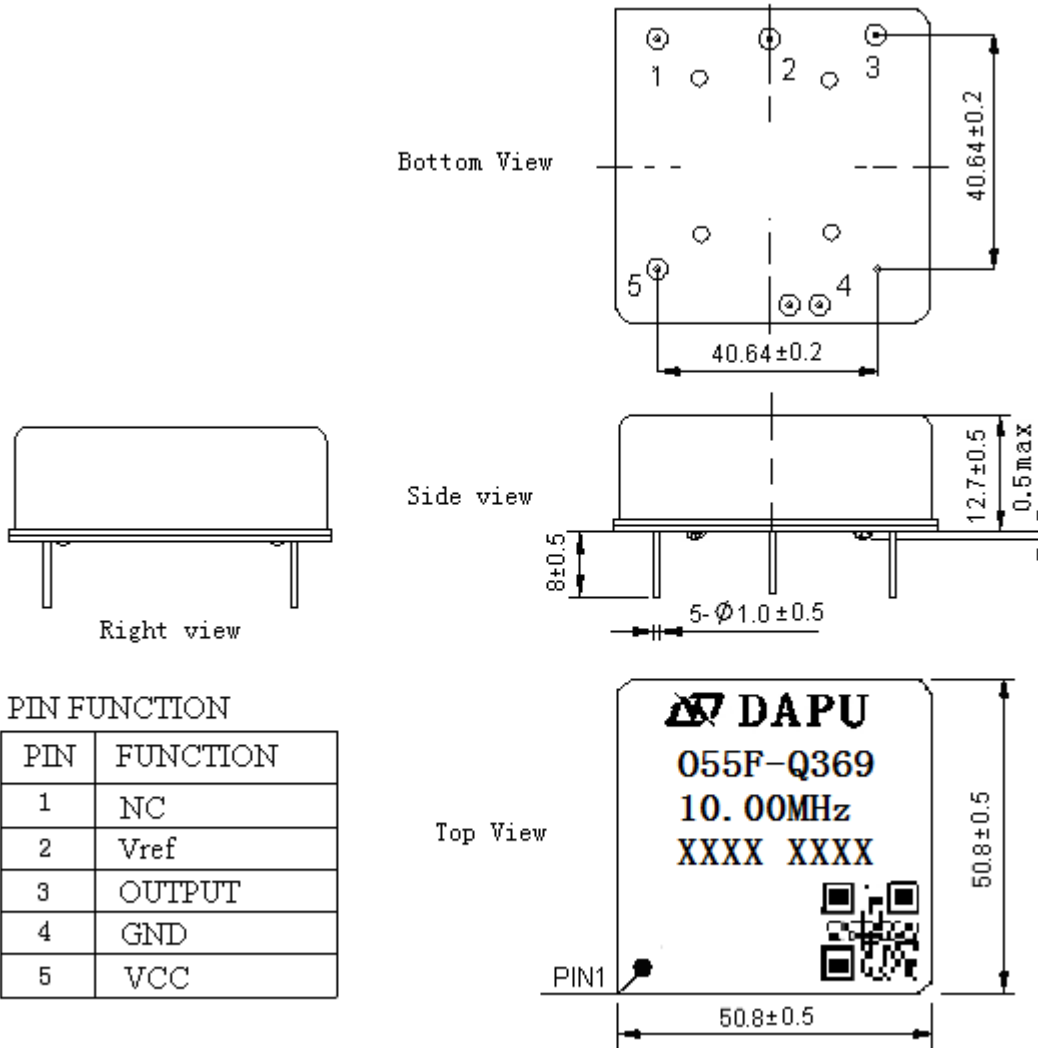

Note1: Tolerance ± 0.2 mm without mark

Note2: The first two xx representative: week

After two xx representative: year

At last four xxxx representative: serial number

Note3: Referential weight 56.1g

Note4: NC is not connect



3、 Test Circuit

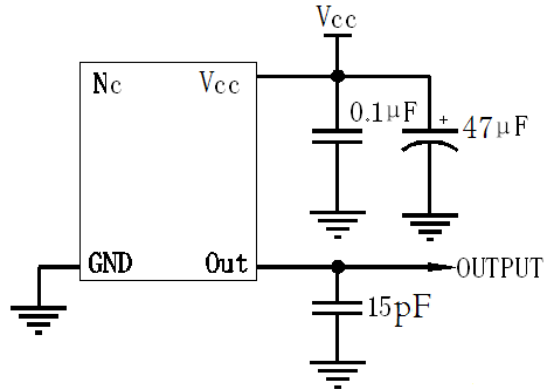

4、 Wave Soldering Curve (RoHS)

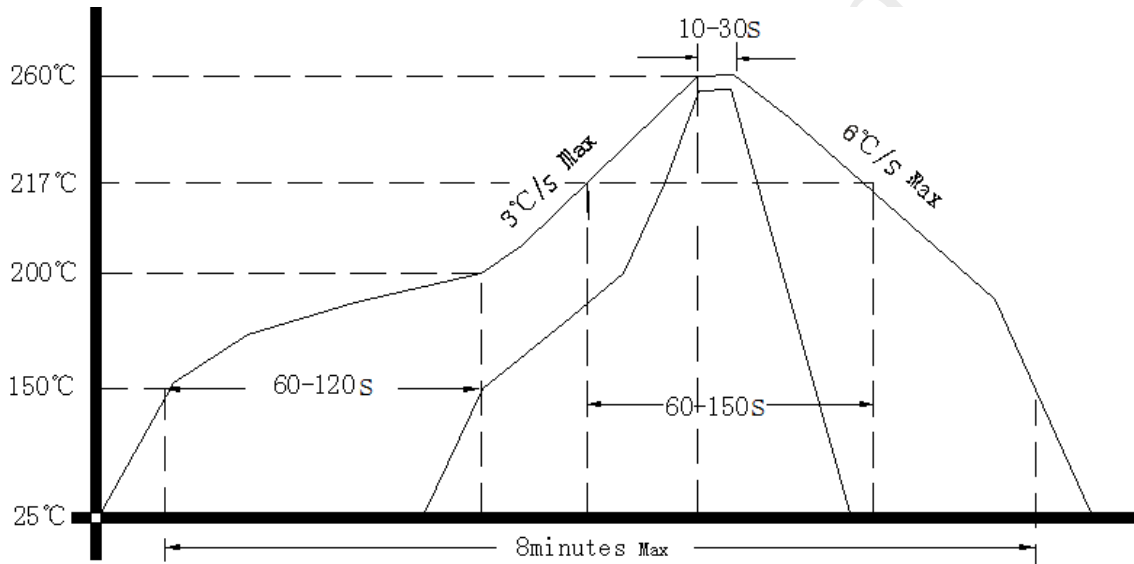

5、 Package (mm)

