

Travelling Merchant: _____

DATASHEET

Standard: DP6X32768002

Plot			The Label
Drew	Audited	Approved	Stamp, please! Thanks!
Date: 2021.12.29			

Guangdong Dapu Telecom Technology Co.,LTD

Building 5, No.24, Industrial East Road, Songshanhu Park, Dongguan, Guangdong, P.R. China

TEL: 0086-0769-88010888 FAX: 0086-0769-81800098



1、 Electrical Parameters

MODEL: DP6X32768002							
No.	Parameters	SYM.	Electrical Spec.				Notes
			Min.	Typ.	Max.	Units	
1	Nominal Frequency	FL	32.768			KHz	
2	Load Capacitance	CL	12.5			pF	
3	Frequency Tolerance	-	-20	~	+20	$\times 10^{-6}$	Ref to 25°C
4	Operating Temperature	-	-40	~	+85	°C	
5	Storage Temperature Range	-	-55	~	+125	°C	
6	Turnover Temperature		20	25	30	°C	
7	Frequency Temperature Curve		-0.04		-0.028	$\times 10^{-6}/^{\circ}\text{C}$	
8	Aging	-	-3	~	+3	$\times 10^{-6}$	+25°C, First year
9	Drive Level	DL	-	-	1	μW	
10	Series Resistance	Rr	-	-	50	K Ω	Ref to 25°C
11	Dynamic capacitance	C1		2.3		fF	
12	Shunt Capacitance C0	C0	0.9	1.3	2	pF	
13	Capacitance Ratio			450			
14	Insulation Resistance	-	500	-	-	M Ω	at DC 100V \pm 15V
15	Quality Factor			75		K	



2、Mechanical Structure(mm)

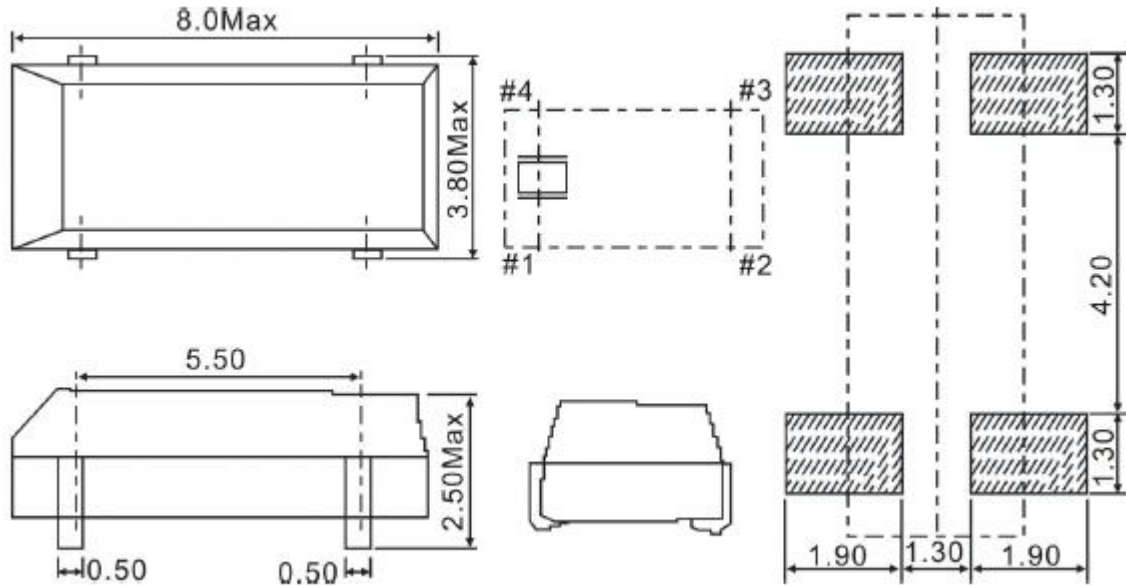

Note1: Tolerance $\pm 0.2\text{mm}$

3、Reflow Soldering

