

Travelling Merchant: _____

DATASHEET

Standard: **DPAF32768005**

Plot			The Label
Drew	Audited	Approved	Stamp, please! Thanks!
Date: 2021.10.13			

Guangdong Dapu Telecom Technology Co.,LTD

Building 5, No.24, Industrial Road East, Songshanhu Park, Dongguan, Guangdong, P.R. China

TEL: 0086-0769-88010888 FAX: 0086-0769-81800098



1、 Electrical Parameters

MODEL: DPAF32768005							
No.	Parameters	SYM.	Electrical Spec.				Notes
			Min.	Typ.	Max.	Units	
1	Nominal Frequency	FL	32.768			KHz	
2	Oscillation Mode	-	Fundamental			-	
3	Load Capacitance	CL	12.5			pF	
4	Frequency Tolerance	-	-20	~	+20	$\times 10^{-6}$	at 25°C \pm 3°C
5	Parabolic Coefficient	-	-0.025	-0.035	-0.045	PPM/°C ²	Values are calculated by frequencies at 10°C, 25°C, and 40°C.
6	Turnover Temperature	TT	20	25	30	°C	
7	Operating Temperature	-	-40	~	+85	°C	
8	Storage Temperature Range	-	-55	~	+125	°C	
9	Aging	-	-3	~	+3	$\times 10^{-6}$	Per year
10	Drive Level	DL	-	0.1	1	uW	
11	Equivalent Series Resistance	Rr	-	-	70	K Ω	
12	Shunt Capacitance C0	C0	0.6	0.9	1.2	pF	
13	Motional Capacitance	C1	3	3.7	4.4	fF	
14	Insulation Resistance	-	500	-	-	M Ω	at DC 100V
15	Quality Factor	Q	13000				



2、Mechanical Structure(mm)

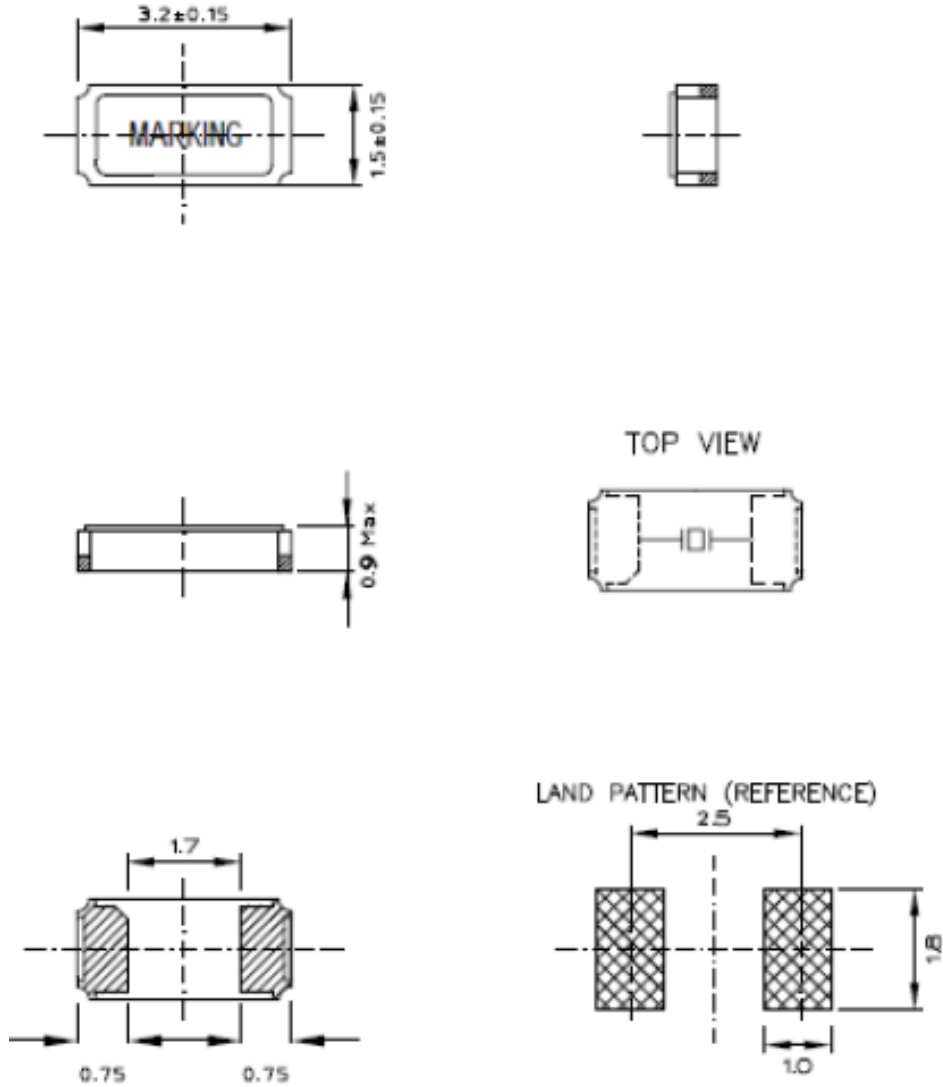



3、 Package: Tape & Reel (mm)

1. CARRIER TYPE

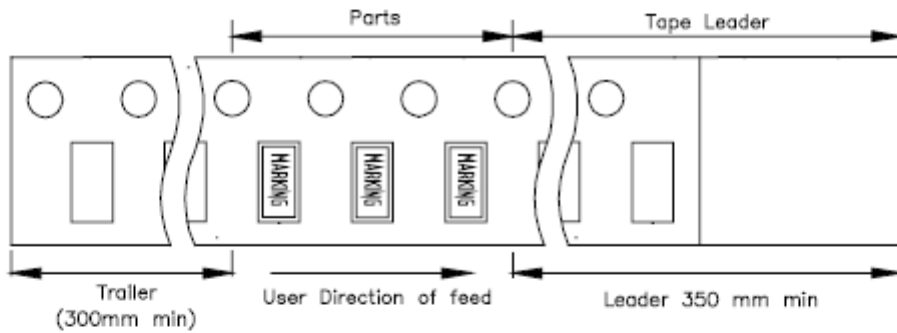
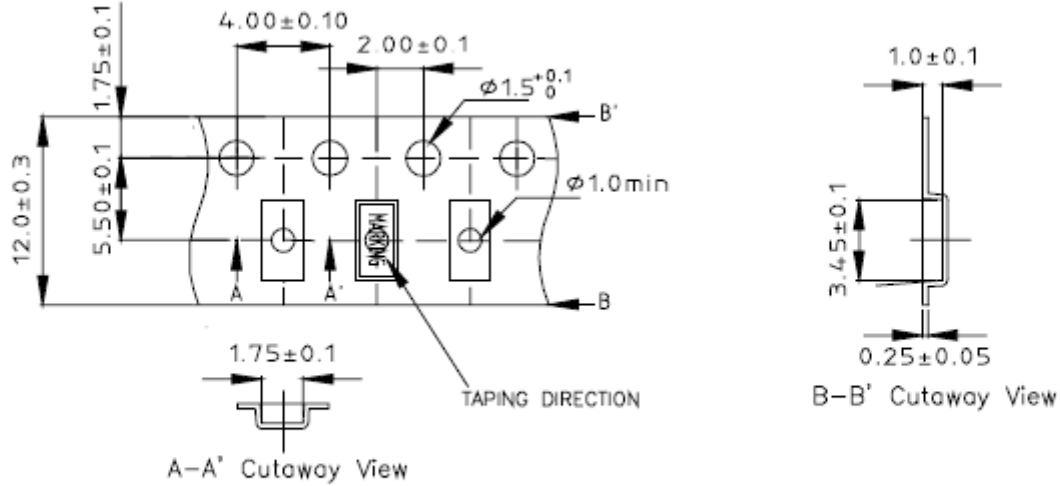

2. REEL : 3000PCS

