



1. Electrical Parameters

MODEL: O11F-1201-10.00MHz						
Item	Description	Parameters			Unit	Test Condition
		Min.	Typ.	Max.		
Output	Frequency	10.00			MHz	
	Output Waveform	LVTTTL				
	Output Low Voltage			0.4	V	$V_{cc}=3.3V$, Load =15pF
	Output High Voltage	2.4			V	$V_{cc}=3.3V$, Load =15pF
	Duty Cycle	45		55	%	Measurement at -40~95°C
	Rise/Fall Time			4	ns	10%~90% V_{CC}
	Load	13.5	15	16.5	pF	
	Start up time			1	s	90% V_{CC} to the correct frequency output time
Frequency Stabilities	Frequency Accuracy	-1.0		+1.0	$\times 10^{-6}$	Within 90 days after shipment and 15 minutes warm up time(before reflow), Measurement referenced to nominal frequency
		-0.1		+0.1	$\times 10^{-6}$	Within 90 days after shipment and 5 minutes warm up time(after reflow), Measurement referenced to initial frequency (after 2 hours and 5 minutes warm up time after reflow)
		-1.0		+1.0	$\times 10^{-6}$	After 2 hours and 5 minutes warm up time (after reflow), Measurement referenced to the frequency (before reflow)
	Frequency Stability vs. Operating Temperature Range	-3.0		+3.0	$\times 10^{-9}$	T_A varied from -40 to 95°C, $V_{cc}=3.3V$, And Load = 15pF. Measurement referenced to frequency observed With $T_A = 25^\circ C$, $V_{cc}=3.3V$.
	Short-Term Stability: Allan Variance		0.01		$\times 10^{-9}$	Temperature stability, no EMI\EMC or other interference, test after power for 1hour ref. to 25°C; 1s.
	Frequency Stability vs. Supply Voltage	-1		1	$\times 10^{-9}$	$T_A = 25^\circ C$, V_{cc} varied from 3.13 to 3.47V and Load =15pF. Measurement referenced to frequency observed with $T_A = 25^\circ C$, $V_{cc}=3.3V$.
	Frequency Tolerance vs Load	-1		1	$\times 10^{-9}$	10% Load Change Measurement referenced to frequency observed with $T_A = 25^\circ C$, $V_{cc}=3.3V$.



	Aging Tolerance per day	-1.0		+1.0	$\times 10^{-9}$	V _{cc} , T _A constant Measurement referenced to frequency observed with TA=25°C, V _{cc} =3.3V. and after 30 days of operation	
	Aging Tolerance 1 Years	-0.15		+0.15	$\times 10^{-6}$		
Power Supply	Supply Voltage	3.13	3.3	3.47	V		
	Steady Consumption			500	mA	@25°C	
	Warm up current			1000	mA	When all temp range	
	Warm Up Time			5	minute		
	Warm Up	-0.05		+0.05	$\times 10^{-6}$	After warm up 10 minute. Measurement referenced to frequency observed with T _A =25 °C ,V _{cc} =3.3V. and after 24 hour of operation.	
Phase Noise	Phase Noise			-80	dBc/Hz	1Hz	
				-120		10Hz	
				-140		100Hz	
				-150		1KHz	
				-150		10KHz	
				-150		100KHz	
Environmental Conditions	Operable Temperature range	-40		+95	°C		
	Operating Temperature	-40		+95	°C		
	Storage Temperature	-55		+105	°C		
	Temperature Rate of Change			1	°C/min		
	Jitter			1.6	ps-rms	12KHz-5MHz	
	Air-tightness			0.1	Pa.cm3/s	Not include PCB conversion board.	
	ESD Level	Human Body Model, class2: 2000V to 4000V; ANSI/ESDA/JEDEC JS-001-2010.					
		Machine Model, class B: 200V to 400V; JEDEC JESD22-A115C.					
	Moisture Sensitivity Level	Level 3.					
	Vibration	Test Condition: 0.75mm ;acceleration:10g;10Hz~500Hz, one cycle per 30 min, test 2 hour. (3 times for each 3 directions X ,Y , Z), IEC 68-2-06 Test Fc.					
Shock	50g; 11ms; half sine wave (3 times for each 3 directions X ,Y , Z),IEC 68-2-27 Test Ea/Severity 50A.						
Full Package Storage	Relative Humidity (%)	20%~70%					
	Temperature (°C)	-10~35°C					



2. Mechanical Structure (mm)

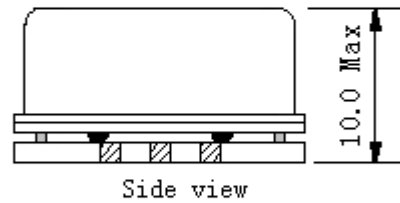
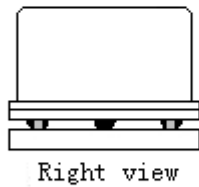
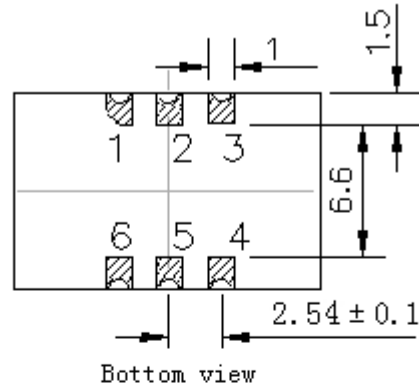
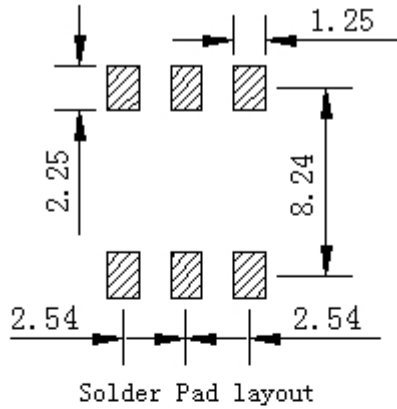

PIN FUNCTION

PIN	NOTATION	FUNCTION
1	NC	Not Connect
2,5	NC	Not Connect
3	GND	GND
4	OUTPUT	RF Output
6	VCC	Supply Voltage

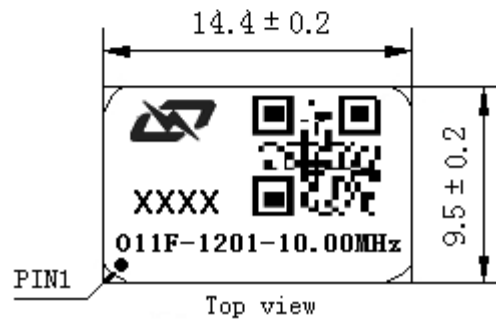

Note1: Tolerance $\pm 0.20\text{mm}$ without mark

Note2: The first two xx representative: week
After two xx representative: year

Note3: Referential weight 5.0g

Note4: NC is not connect



5. Test Circuit

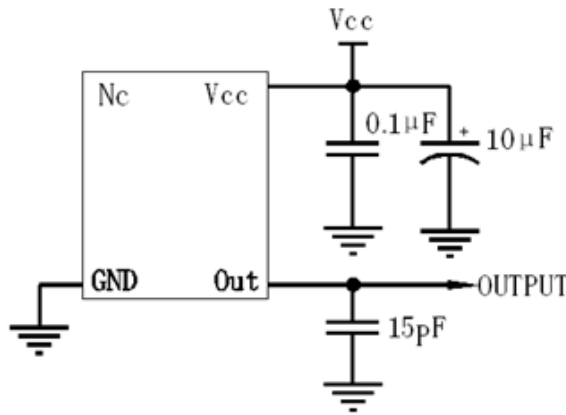

6. Reflow Soldering Curve (RoHS)

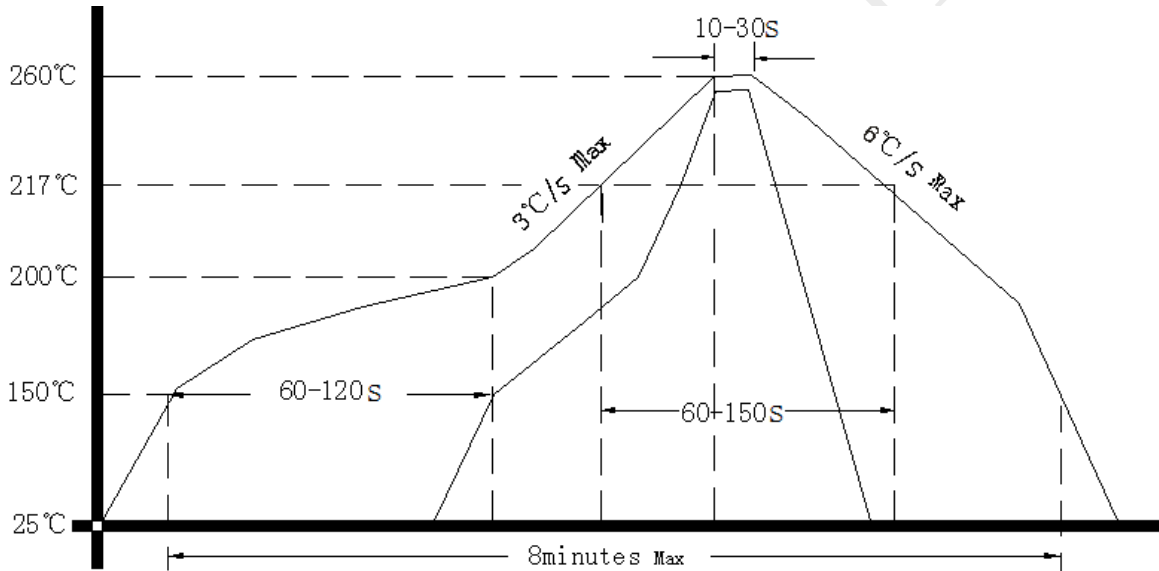

7. Package: Tape & Reel (mm)

