



1. Electrical Parameters

MODEL: O22S-0807-10.00MHz							
Item	Description	Parameters			Unit	Test Condition	
		Min.	Typ.	Max.			
Output	Frequency	10.00			MHz		
	Output Waveform	LVTTTL					
	Output Overshoot			10	%		
	Output Low Voltage			0.4	V	Vcc=3.3V, load=15pF	
	Output High Voltage	2.4			V	Vcc=3.3V, load=15pF	
	Duty Cycle	45		55	%		
	Rise / Fall Time (10%~90%)			4	ns		
	Load	13.5	15	16.5	pF		
	Start-up time			0.8	s		
	Spurious			-90	dBc		
Frequency Stabilities	Frequency Tolerance vs. Operating Temperature Range			3	$\times 10^{-9}$	TA varied from -40°C to 85°C, measurement referenced to frequency observed with pk-pk, Vcc=3.3V, load=15pF, temperature variable speed less than 2°C per minute.	
		-100		+100	$\times 10^{-9}$	TA varied from -40°C to 90°C.	
	Initial Frequency Tolerance	-1		+1	$\times 10^{-6}$	Measurement referenced to frequency observed with TA=25°C, Vcc=3.3V, and after 15 minutes of operation, within 90 days after ex-works	
	Frequency Tolerance vs. Supply Voltage	-0.1		+0.1	$\times 10^{-9}$	measurement referenced to frequency observed TA=25°C, Vcc varied from 3.234V to 3.366V, and Load=15pF.	
	Frequency Tolerance vs. Load	-0.2		+0.2	$\times 10^{-9}$	10% load change measurement referenced to frequency observed with TA=25°C, Vcc=3.3V, and Load=15pF.	
	Micro jump	-0.5		+0.5	$\times 10^{-9}$	Continuous testing for 7 days, temperature Fluctuations < $\pm 5^\circ\text{C}$, one sampling/10s.	
	Temperature hysteresis effect	-0.5		+0.5	$\times 10^{-9}$	Over temperature range(10°C/hour)	
	Reflow shift		-0.1		+0.1	$\times 10^{-6}$	within 90 days after ex-works, put 2 hours after reflow soldering and power on for 5 minutes, relative to the frequency deviation after ex-works
			1		1	$\times 10^{-6}$	within 90 days after ex-works, put 2 hours after reflow soldering and power on for 5 minutes, relative to standard frequency deviation
Retrace	-0.01		+0.01	$\times 10^{-6}$	After 24 hour off at 25°C 15min power on		



	Short-Term Stability Allan Variance			0.005	$\times 10^{-9}$	Temperature stability, no EMI/EMC or other interference, test after power for 1hour ref. to 25°C; 1s.
				0.015	$\times 10^{-9}$	Temperature stability, no EMI/EMC or other interference, test after power for 1hour ref. to 25°C; 10s.
				0.03	$\times 10^{-9}$	Temperature stability, no EMI/EMC or other interference, test after power for 1hour ref. to 25°C; 100s.
	Aging Tolerance Per Day	-0.3		+0.3	$\times 10^{-9}$	Vcc,TA constant measurement referenced to frequency observed with TA=25°C,Vcc=3.3V, and after 30 days of operation.
	Aging Tolerance 1 Year	-0.03		+0.03	$\times 10^{-6}$	
	Aging Tolerance 10 Year	-0.25		+0.25	$\times 10^{-6}$	
	Aging Tolerance 15 Year	-0.3		+0.3	$\times 10^{-6}$	
Power Supply	Supply Voltage	3.135	3.3	3.465	V	
	Steady Consumption			400	mA	@25°C
	Warm up current			1000	mA	
	Warm-Up Time			10	minutes	@25°C within $\pm 0.01 \times 10^{-6}$ of final frequency with reference after 1 hour on.
Phase Noise	Phase Noise			-85	dBc/Hz	1Hz
				-115		10Hz
				-135		100Hz
				-145		1KHz
				-150		10KHz
				-150		100KHz
				-150		1MHz
Jitter	Jitter		0.9	1.8	ps	RMS (12KHz ~5MHz)
Acceleration sensitivity	Acceleration sensitivity			4	ppb/g	Gamma vector,3-axes,30-1500Hz,typically less than



Environmental Conditions	Operating environmental condition	-40		+85	°C		
	Storage Temperature	-55		+105	°C		
	Relative Humidity	5		85	%		
	Air-tightness			0.02	$\times 10^{-6}$ pa.m ³ /s	Leak detection by He mass spectrometry: 2hrs@4 atmospheric pressure, no more than 1H static time.	
	ESD Level	Human Body Model, class2: 2000V to 4000V; ANSI/ESDA/JEDEC JS-001-2010.					
		Machine Model, class B: 200V to 400V; JEDEC JESD22-A115C.					
	Moisture Sensitivity Level	Level 3.					
Vibration	Sweep frequency sine wave, frequency: 10-55 Hz, maximum amplitude 1.0 mm (peak value), 55-1 KHz, maximum acceleration 10 g. Each axis 1H (3 axes 6 directions), sweep rate 1 octave/min.						
Shock	100g; 6ms; half sine wave (3 times for each 3 directions X, Y, Z).						
Full Package Storage	Relative humidity (%)	20% ~70%					
	Temperature (°C)	-10~35°C					



2、 Mechanical Structure (mm)

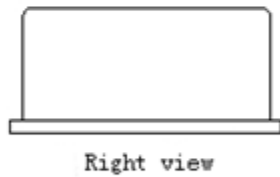
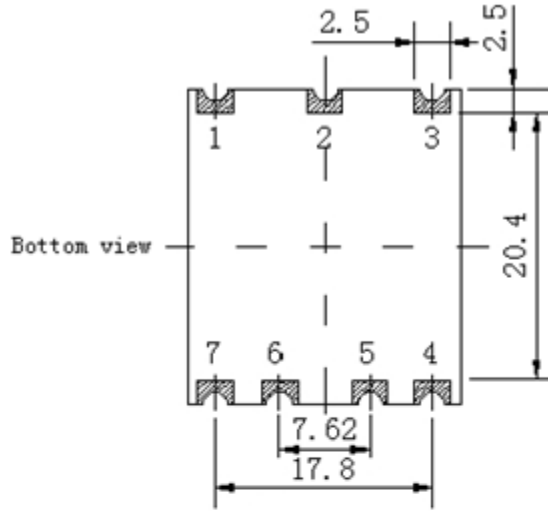
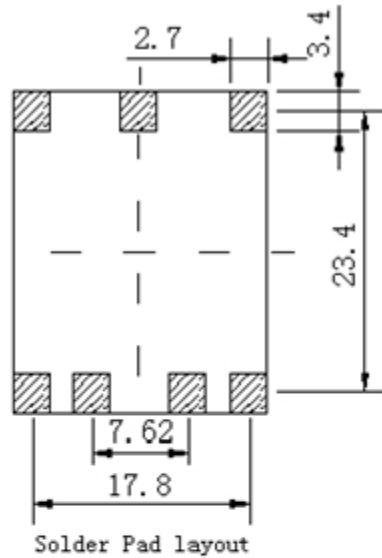

PIN FUNCTION

PIN	FUNCTION
1	NC
2	NC
3	Supply Voltage
4	Output
5	SCL
6	SDA
7	GND

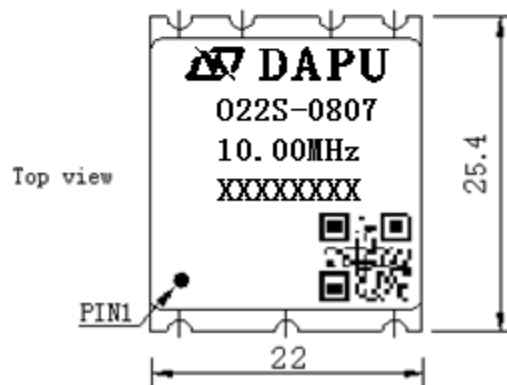

Note1: Tolerance ± 0.2 mm without mark

Note2: The first two xx representative: week

After two xx representative: year

At last four xxxx representative: serial number

Note3: Referential weight 8.0g

Note4: NC is not connect

Note5: Bar-code should include supplier code (20004800),

batch No, week and year code, serial No.

For example, the 200th part produced in the 48th week in 2017,

bar-code is 2000480048170200.



3、I2C Devices Address

3.1. 2kbit I²C SERIAL EEPROM

Device name : 24C02

Device address : 1010 100

Memory map

Address	Size bytes	Parameter	Format	Value
0000h~0000h	1	EEPROM map version	Unsigned byte	01h
0001h~0001h	1	Reserved		00h
0002h~0004h	3	Vendor ID(3 characters)	ASCII	DP
0005h~0024h	32	Vendor Product ID	ASCII	O22S-0807-10.00MHz
0025h~0028h	4	Nominal frequency in Hertz	32-bit unsigned integer	10000000
0029h~002Ch	4	Device serial number	32-bit unsigned integer	001
002Dh~0032h	6	Date code of manufacture	ASCII	“WWYY”
0033h~003Fh	13	Reserved		00h
0040h~0047h	8	Initial Frequency Note1	64-bit floating point	64-bit floating-point type, refer to IEEE754
0048h~004Fh	8	Aging Note 2	64-bit floating	
0050h~0057h	8	Frequency stability vs. temp Note 3	64-bit floating point	
0058h~005Fh	8	Steady state current Note 4	64-bit floating point	
0060h~00FFh	160	Reserved		00h

Note1: Initial frequency after ex-works, unit: ppb

Note2: Aging per day after ex-works, unit: ppb

Note3: Frequency stabilities & Operating Temperature Range (pk-pk) after ex-works, unit: ppb

Note4: Steady state current, unit: mA

3.2. Analog-to-Digital Converter

Device name : NCT75/SGM452

Device supplier : ON/SGMICRO

Device address : 1001000

Note: More detailed information see the datasheet provide by the ON/SGMICRO.



4. Test Circuit

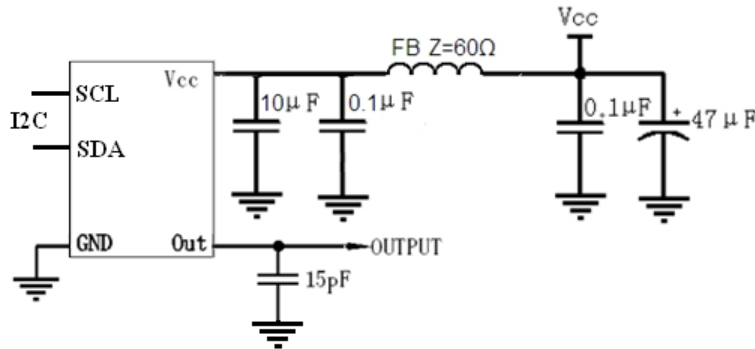

5. Reflow Soldering Curve (RoHS)

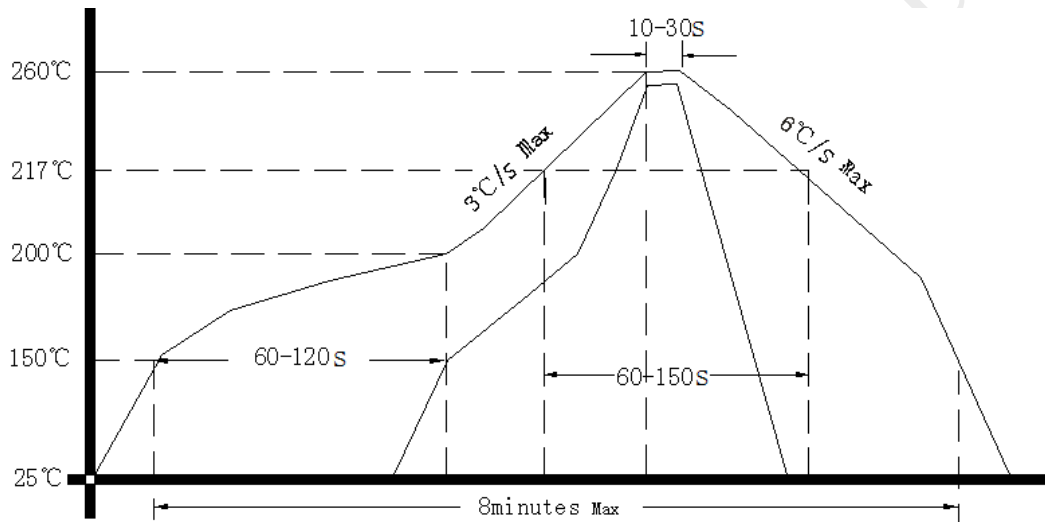

6. Current vs. Temperature Curve

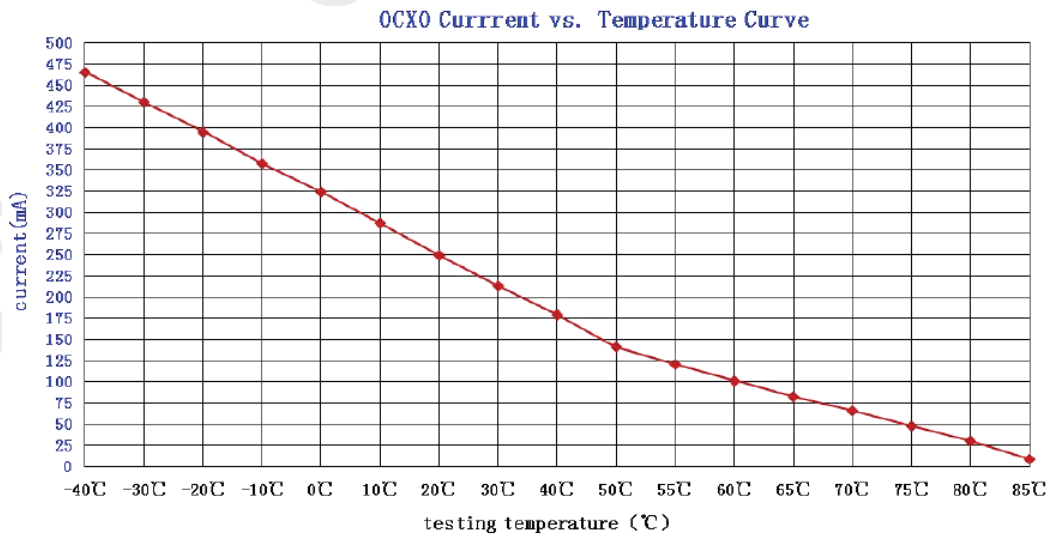



7. Mirco Jump

Case1:

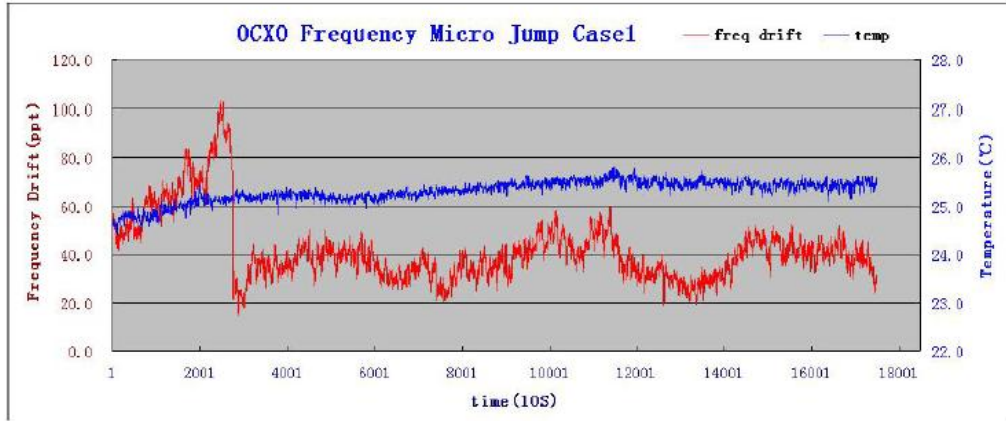

Case2:

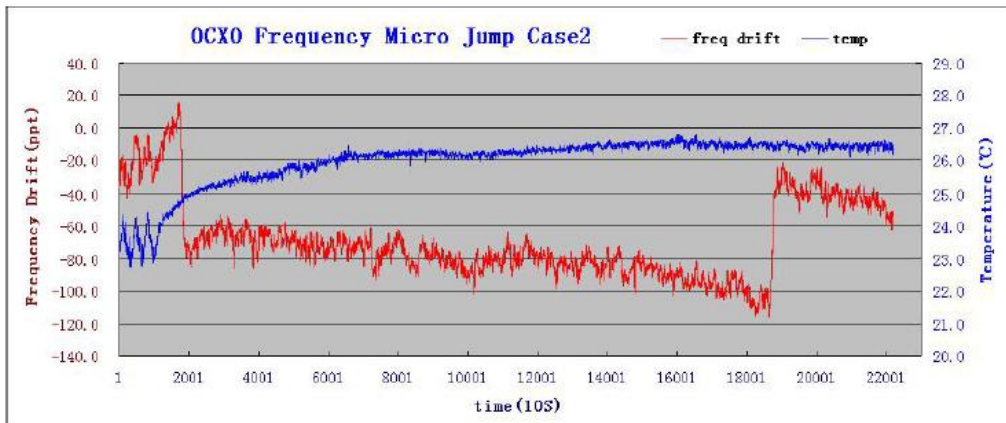

8. Package: Tape & Reel (mm)

