

Travelling Merchant: _____

DATASHEET

Standard: DP7W24000012

Plot			The Label
Drew	Audited	Approved	Stamp, please! Thanks!
Date:			

Guangdong Dapu Telecom Technology Co.,Ltd

Bldg13,.N.Ind.Zone,SSL Industry Park, Dongguan City, Guangdong Province, China

TEL: 0086-0769-88010888 FAX: 0086-0769-81800098



1、Electrical Parameters

MODEL: DP7W24000012							
No.	Parameters	SYM.	Electrical Spec.				Notes
			Min.	Typ.	Max.	Units	
1	Nominal Frequency	FL	24.00			MHz	
2	Frequency Stability	-	-30		+30	ppm	-40~85°C
3	Operating Temperature	Topr	-40		85	°C	
4	Storage Temperature	Tstg	-40	~	85	°C	
5	Supply Voltage	VDD	3.3±10%			V	
6	Input Current	Icc	-	-	20	mA	
7	Frequency Tolerance	-	-20		+20	ppm	@25°C
8	Output Load: CMOS	CL	15			pF	
9	Output Voltage High	VoH	90% Vdd	-	-	V	
10	Output Voltage Low	Vol	-	-	10% Vdd	V	
11	Rise Time	Tr	-	-	6	ns	10%-90% VDD Level
12	Fall Time	Tf	-	-	6	ns	90%-10% VDD Level
13	Symmetry (Duty ratio)	TH/T	40	50	60	%	
14	Aging	-	±5			ppm/yr.	1st. Year at 25°C



2、Mechanical Structure(mm)

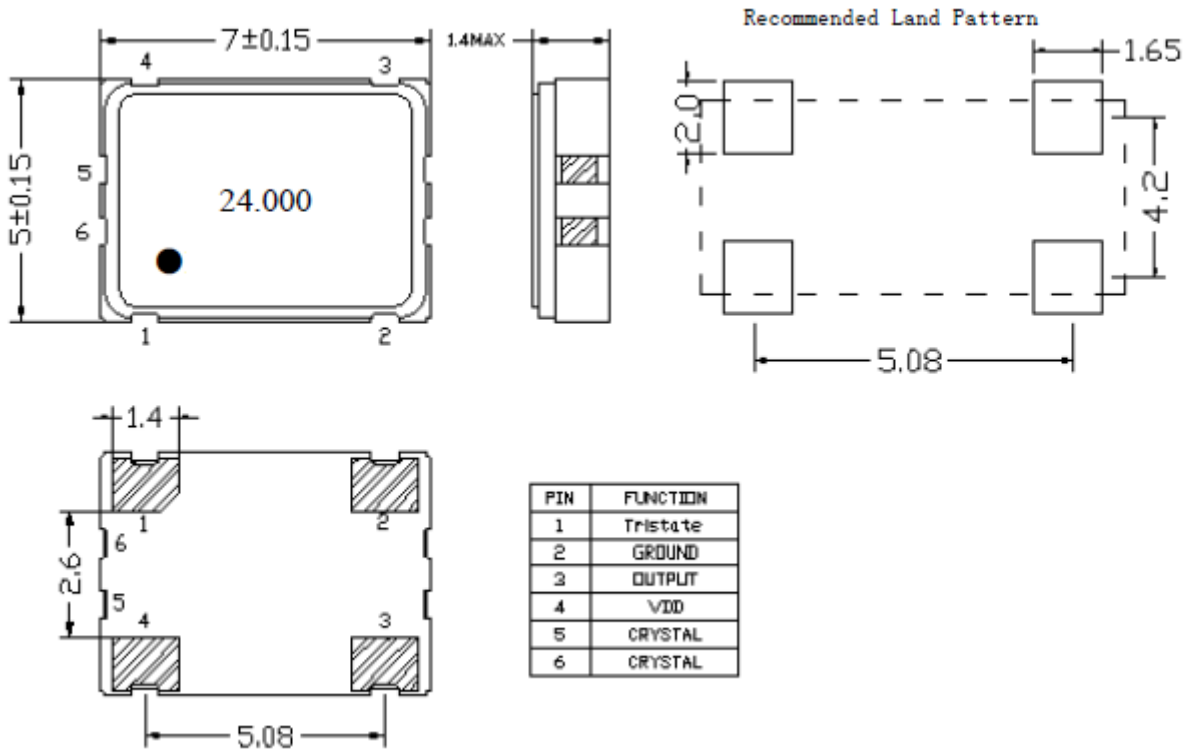

3、Package: Tape & Reel (mm)

