

Travelling Merchant: _____

DATASHEET

Standard: **T32-C563-38.40MHz**

P/N: _____

Plot			The Label
Drew	Audited	Approved	Stamp, please! Thanks!
Date: 2020.11.12			

Guangdong Dapu Telecom Technology Co.,Ltd

Bldg13-16,.N.Ind.Zone,SSL Industry Park, Dongguan City, Guangdong Province, China

TEL: 0086-0769-88010888 FAX: 0086-0769-81800098



1、Electrical Parameters

MODEL: T32-C563-38.40MHz							
Item	Description	Parameters			Unit	Test Condition	
		Min.	Typ.	Max.			
Output	Frequency	38.40			MHz		
	Output Waveform	Clipped Sine Wave					
	Vp-p	0.8			V		
	Duty Cycle	40		60	%	GND level (DC-cut)	
	Start up				3	ms	@90% of Final Vout level
					3	ms	Within ± 2 ppm of final frequency
	Load	10K Ω //10pF					
Frequency Stabilities	Total Tolerance	-3		+3	$\times 10^{-6}$	Temp.variation of (-30 $^{\circ}$ C to 85 $^{\circ}$ C),Supply variation of (3 \pm 5%DC),Load variation of (10K Ω //10pF) \pm 10%	
	Initial Frequency Tolerance	-1.5		+1.5	$\times 10^{-6}$	@25 $^{\circ}$ C, Vc=1.5V, before reflow soldering	
		-2.5		+2.5	$\times 10^{-6}$	@25 $^{\circ}$ C, Vc=1.5V, after reflow soldering	
	Aging Tolerance 5Years	-3		+3	$\times 10^{-6}$	T _A =Room ambient.	
Power Supply	Operating Current			1.8	mA	@25 $^{\circ}$ C, V _{cc} =3.0V, V _c =1.5V, O _{Load} =10K Ω //10pF.	
	Supply Voltage	2.85	3.0	3.15	V		
Voltage Control	Frequency tuning range	-15		-9	$\times 10^{-6}$	V _c = 0V. measurement referenced to V _c =1.5V.	
		-1.5		+1.5	$\times 10^{-6}$	V _c =1.5V. measurement referenced to Exactly 19.20MHz.	
		+9		+15	$\times 10^{-6}$	V _c =2.5V. measurement referenced to V _c =1.5V.	
	Slope	Positive					
Environmental Conditions	Operable Temperature	-30		+85	$^{\circ}$ C		
	Storage Temperature	-40		+85	$^{\circ}$ C		
	ESD Level	Human Body Model,class2: 2000V to 4000V; ANSI/ESDA/JEDEC JS-001-2010.					
		Machine Model, class B: 200V to 400V; JEDEC JESD22-A115C.					
	Moisture Sensitivity Level	Level 2.					
Vibration	Test Condition: 0.75mm ;acceleration:10g;10Hz~2000Hz, one cycle per 30 min, test 2 hour. (3 times for each 3 directions X ,Y , Z) .IEC 68-2-06 Test Fc.						



2、 Mechanical Structure(mm)

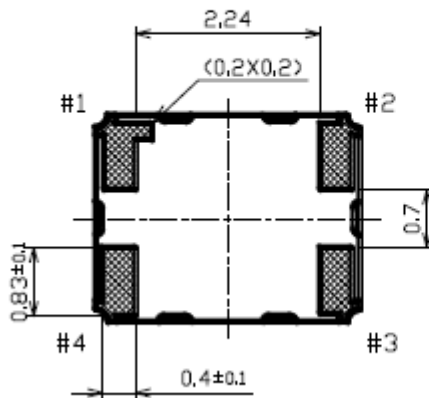
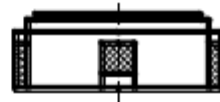
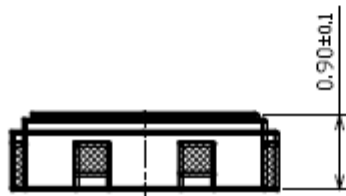
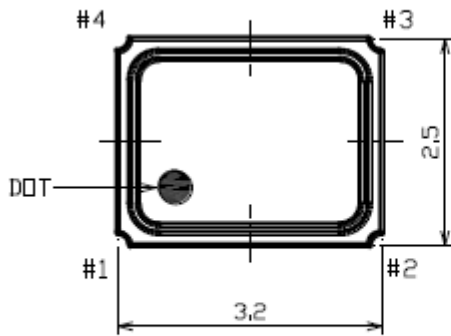

PIN FUNCTION

PIN	FUNCTION
1	VC
2	GND
3	OUTPUT
4	VCC

Note1: Tolerance ± 0.15 mm without mark

Note2: Referential Weight 0.03g



3、 Test Circuit

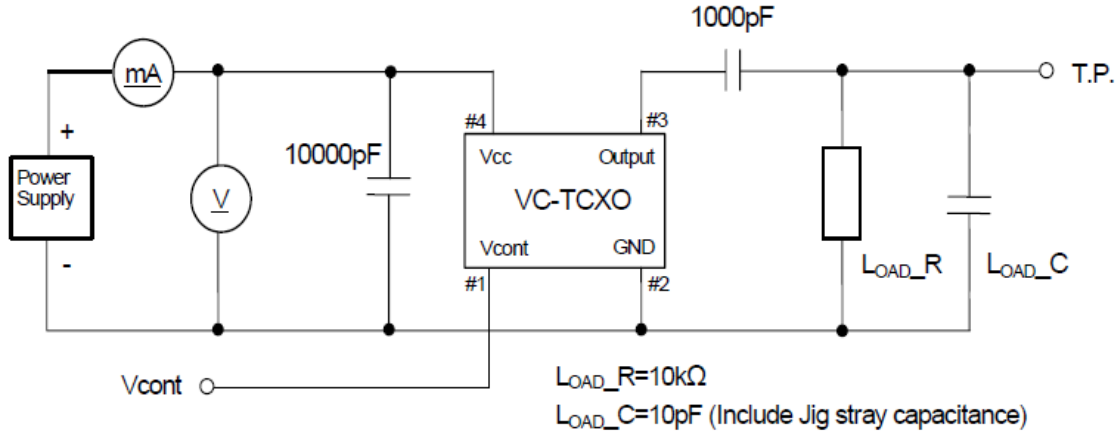

4、 Reflow Soldering Curve (RoHS)

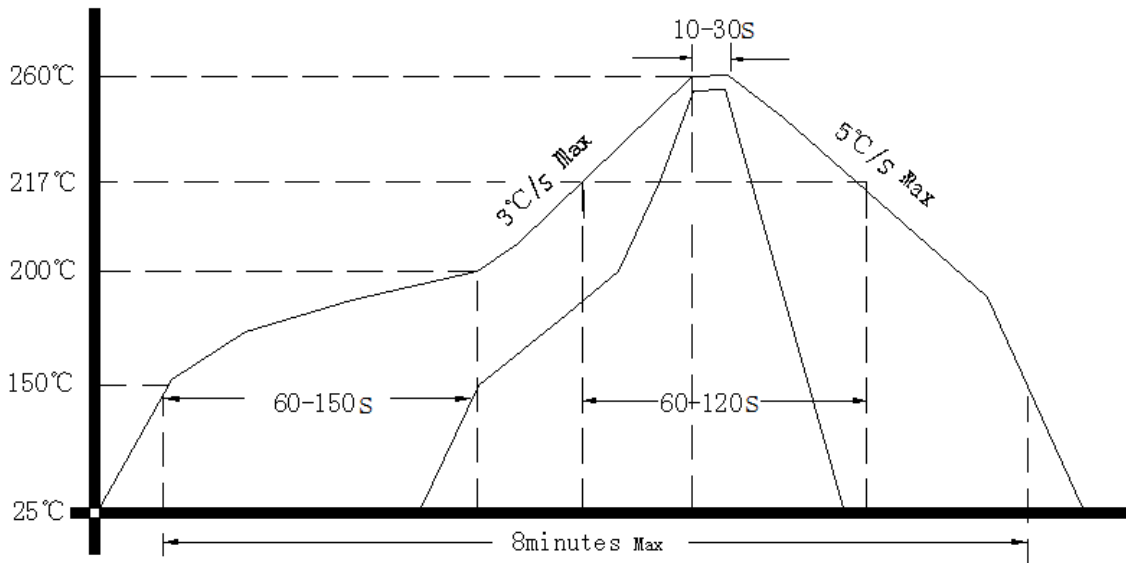

5、 Package: Tape & Reel (mm)

