

Travelling Merchant: \_\_\_\_\_

# DATASHEET

Standard:     **T22-S539-26.00MHz**    

P/N: \_\_\_\_\_

Plot			The Label
Drew	Audited	Approved	Stamp, please! Thanks!
Date: 2020.11.09			

**Guangdong Dapu Telecom Technology Co.,Ltd**

Bldg 16,.N.Ind.Zone,SSL Industry Park, Dongguan City, Guangdong Province, China

TEL: 0086-0769-88010888 FAX: 0086-0769-81800098





## 1. Electrical Parameters

MODEL: T22-S539-26.00MHz							
Item	Description	Parameters			Unit	Test Condition	
		Min.	Typ.	Max.			
Output	Frequency	26.00			MHz		
	Output Waveform	Clipped Sine Wave					
	Vp-p	0.8			V		
	Start up time			2	ms	More than 90% of final amplitude.	
	Load	10KΩ//10pF					
Frequency Stabilities	Frequency Tolerance vs. Operating Temperature Range	-0.5		+0.5	$\times 10^{-6}$	T <sub>A</sub> varied from -30°C to 85°C, measurement referenced to frequency observed with T <sub>A</sub> =25°C, O <sub>load</sub> =10KΩ//10pF, temperature variable speed less than 2°C per minute.	
	Nominal Frequency Tolerance	-1		+1	$\times 10^{-6}$	After 2 times reflow, Ref.to nominal frequency, Please leave after reflow in 2h or more at room ambient.	
	Frequency Tolerance vs. Supply Voltage	-0.2		+0.2	$\times 10^{-6}$	measurement referenced to frequency observed T <sub>A</sub> =25°C, V <sub>cc</sub> ±5% and O <sub>Load</sub> =10KΩ//10pF.	
	Frequency Tolerance vs. Load	-0.2		+0.2	$\times 10^{-6}$	10% load change measurement referenced to frequency observed with T <sub>A</sub> =25°C, V <sub>cc</sub> ±5%, and O <sub>Load</sub> =10KΩ//10pF.	
	Reflow soldering	-1		+1	$\times 10^{-6}$	2 times.	
	Slope		-0.1		+0.1	$\times 10^{-6}/^{\circ}\text{C}$	-20°C ~ +70°C, Every 2°C.
			-0.2		+0.2	$\times 10^{-6}/^{\circ}\text{C}$	-30°C ~ -20°C, Every 2°C.
			-0.2		+0.2	$\times 10^{-6}/^{\circ}\text{C}$	+70°C ~ +85°C, Every 2°C.
Aging Tolerance 1 Year	-1		+1	$\times 10^{-6}$	T <sub>A</sub> =25°C, V <sub>cc</sub> ±5%, and after 1h of operation.		
Power Supply	Operating Current			1.5	mA	@25°C, V <sub>cc</sub> ±5%, O <sub>Load</sub> =10KΩ//10pF.	
	Supply Voltage	1.8		3	V		
Phase Noise	Phase Noise		-92		dBc/Hz	10Hz	
			-116			100Hz	
			-137			1KHz	
			-144			10KHz	
			-144			100KHz	



Environmental Conditions	Operating Temperature	-30		+85	°C	
	Storage Temperature	-40		+85	°C	
	ESD Level	Human Body Model, class2: 2000V to 4000V; ANSI/ESDA/JEDEC JS-001-2010.				
		Machine Model, class B: 200V to 400V; JEDEC JESD22-A115C.				
	Moisture Sensitivity Level	Level 2.				
	Vibration	Test Condition: 0.75mm ;acceleration:10g;10Hz~2000Hz, one cycle per 30 min, test 2 hour. (3 times for each 3 directions X , Y , Z ) .IEC 68-2-06 Test Fc.				
Shock	100g; 6ms; half sine wave (3 times for each 3 directions X , Y , Z ),IEC 68-2-27 Test Ea/Severity 50A.					
Full Package Storage	Relative humidity (%)	20% ~70%				
	Temperature (°C)	-10~35°C				

## 2. Mechanical Structure(mm)

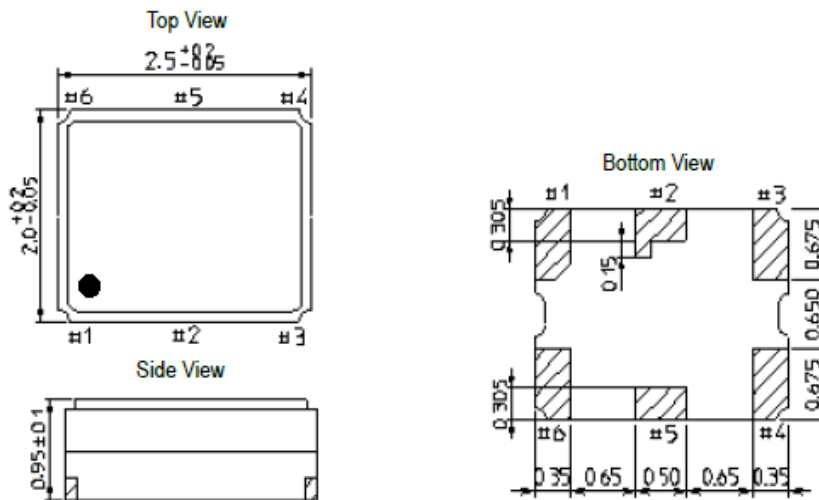

### Recommended Land Pattern

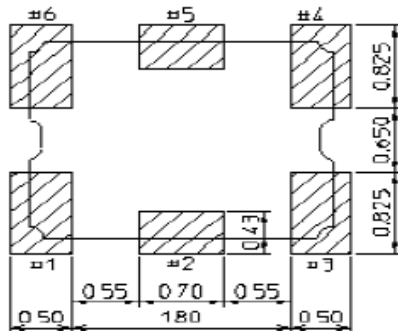

Pad No.	Connection
#1	GND
#3	GND
#4	Output
#6	Vcc
#2,#5	N.C.

**Note1:** Tolerance  $\pm 0.1$ mm without mark

**Note2:** Referential weight 0.01g



### 3. Test Circuit

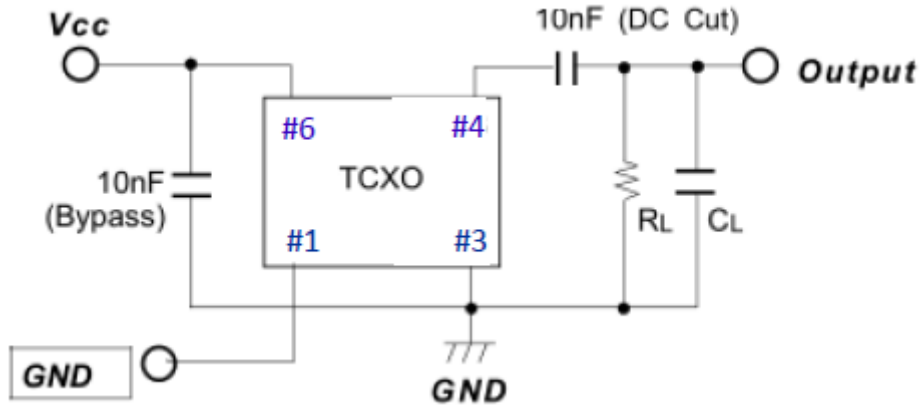

### 4. Reflow Soldering Curve (RoHS)

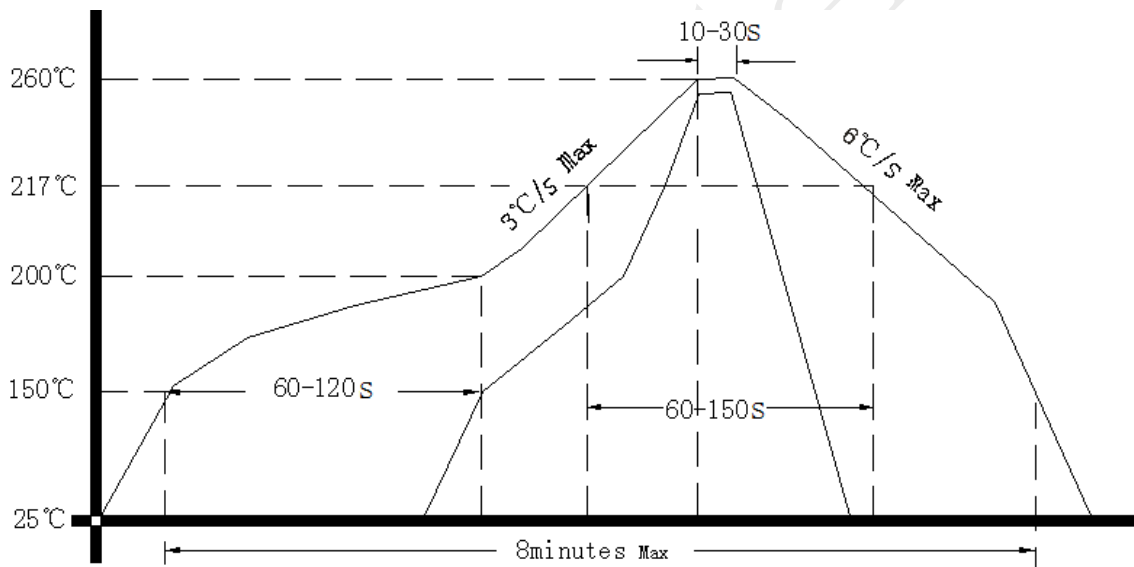

### 5. Package: Tape & Reel (mm)

