

Travelling Merchant: \_\_\_\_\_

# DATASHEET

Standard:     **T1612-P579-26.00MHz**    

P/N: \_\_\_\_\_

Plot			The Label
Drew	Audited	Approved	Stamp, please! Thanks!
Date: 2020.11.09			

**Guangdong Dapu Telecom Technology Co.,Ltd**

Bldg13-16,.N.Ind.Zone,SSL Industry Park, Dongguan City, Guangdong Province, China

TEL: 0086-0769-88010888 FAX: 0086-0769-81800098





## 1. Electrical Parameters

MODEL: T1612-P579-26.00MHz						
Item	Description	Parameters			Unit	Test Condition
		Min.	Typ.	Max.		
Output	Frequency	26.00			MHz	
	Output Waveform	Clipped Sine Wave				
	Vp-p	0.8			V	
	Load	10KΩ//10pF				
Frequency Stabilities	Frequency Tolerance	-2		+2	$\times 10^{-6}$	@25°C ± 2°C, after 2 times reflow soldering, based on nominal frequency.
	vs. Temperature Range	-0.5		+0.5	$\times 10^{-6}$	T <sub>A</sub> varied from -30°C to 85°C, measurement referenced to frequency observed with T <sub>A</sub> =25°C ± 2°C, V <sub>cc</sub> =1.8V, O <sub>load</sub> =10KΩ//10pF, temperature variable speed less than 2°C per minute.
	Frequency Tolerance vs. Supply Voltage	-0.1		+0.1	$\times 10^{-6}$	5% Voltage change measurement referenced to frequency observed T <sub>A</sub> =25°C, and O <sub>Load</sub> =10KΩ//10pF.
	Frequency Tolerance vs. Load	-0.1		+0.1	$\times 10^{-6}$	10% load change measurement referenced to frequency observed with T <sub>A</sub> =25°C, V <sub>cc</sub> =1.8V, and O <sub>Load</sub> =10KΩ//10pF.
	Aging Tolerance 1 Year	-1		+1	$\times 10^{-6}$	T <sub>A</sub> =25°C, V <sub>cc</sub> =1.8V, and after 1h of operation.
Power Supply	Operating Current			1.5	mA	@25°C, V <sub>cc</sub> =1.8V
	Supply Voltage	1.68	1.8	3.63	V	
Environmental Conditions	Operable Temperature	-30		+85	°C	
	Storage Temperature	-40		+85	°C	
	ESD Level	Human Body Model, class2: 2000V to 4000V; ANSI/ESDA/JEDEC JS-001-2010.				
		Machine Model, class B: 200V to 400V; JEDEC JESD22-A115C.				
	Moisture Sensitivity Level	Level 2.				
	Vibration	Test Condition: 0.75mm ;acceleration:10g;10Hz~2000Hz, one cycle per 30 min, test 2 hour. (3 times for each 3 directions X, Y, Z) .IEC 68-2-06 Test Fc.				
Shock	100g; 6ms; half sine wave (3 times for each 3 directions X, Y, Z) ,IEC 68-2-27 Test Ea/Severity 50A.					
Full Package Storage	Relative humidity (%)	20% ~ 70%				
	Temperature (°C)	-10~35°C				



## 2. Mechanical Structure(mm)

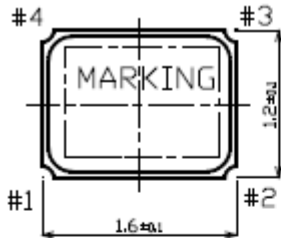

### Marking

- (1) Lot No.
- (2) Manufacture Code
- (3) Nominal frequency (MHz)
- (4) Trace code

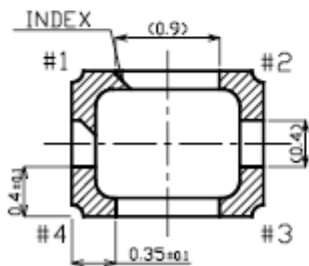
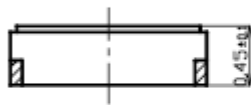

PAD No.	Terminal land Connections
#1	N/C or GND (ground recommended)
#2	GND
#3	OUTPUT
#4	V <sub>CC</sub>

**Note1:** Tolerance  $\pm 0.1\text{mm}$  without mark



### 3. Test Circuit

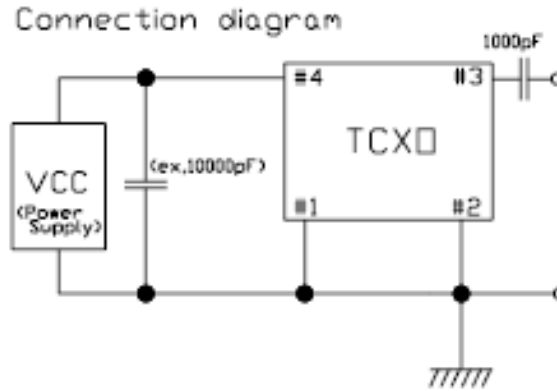

### 4. Reflow Soldering Curve (RoHS)

