

RoHS COMPLIANT

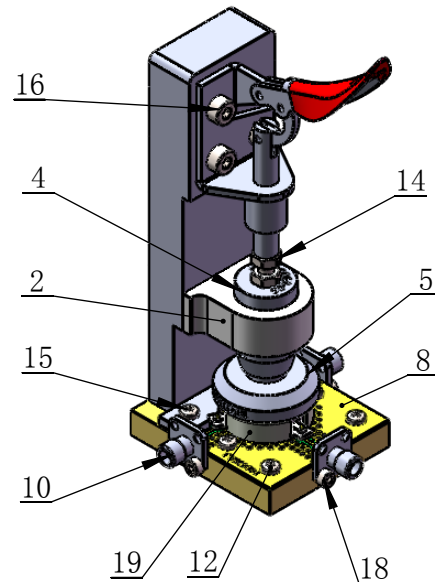
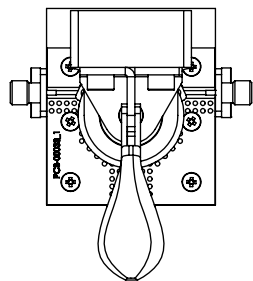
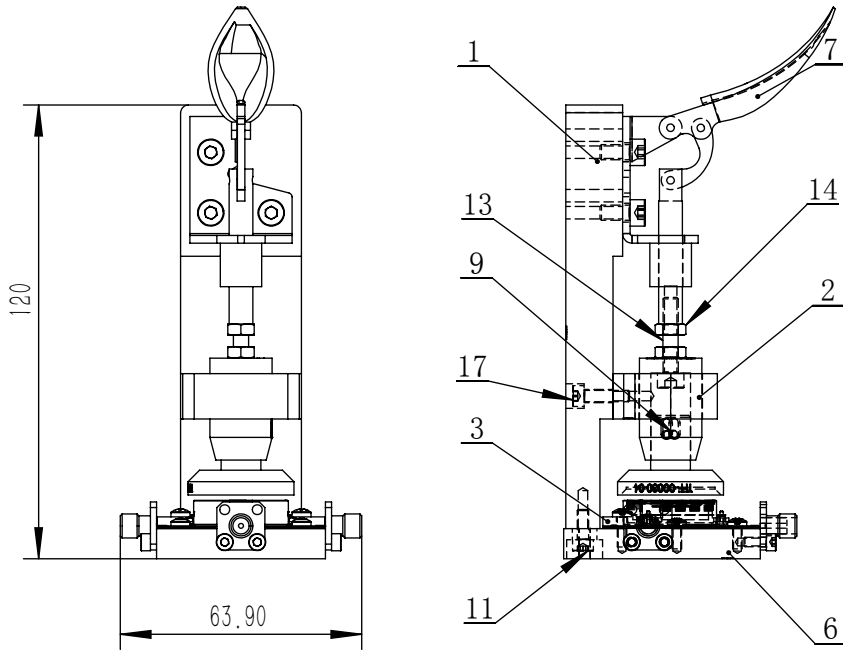

REVISIONS

REV.	DESCRIPTION	DATE	APPROVAL
1		2020/8/18	
2		2020/9/16	

注：4和5之间内置弹簧SPR-00001
(线径1.6x外径10x长度15)



项目号	零件号	说明	数量
1	TFF-00011-02	Fixed Block	1
2	TFF-00002-02	Guide Block	1
3	TFF-00030-03	Limited Block	1
4	TFF-00002-05	Pressure Head Fixing Seat	1
5	TFF-00030-04	Pressure Head	1
6	TFF-00046-01	Test Block	1
7	TAS-00088	GH-301-AM	1
8	PCB-00033	PCB	1
9	DOW-00002	DOWEL $\Phi 2.0 \times 16$	1
10	CON-00001	CONNECTOR SMA-F	3
11	SCR-00023	Screw 内六角圆柱头 M3x8	2
12	SCR-00001	SCREW 十字盘头 M2.5X6	4
13	SCR-00002	Screw 内六角圆柱头 M4X20	1
14	NUT-00001	M4 Nut	2
15	SCR-00003	Screw 十字盘头 M2.5X8	2
16	SCR-00004	Screw 内六角圆柱头 M4X8	3
17	SCR-00005	Screw 内六角圆柱头 M3x12	2
18	SCR-00008	M2.5X6内六角螺丝	6
19	PRODUCT	SMT CIRCULATOR	1

PART NAME: 测试夹具	Designed:	ZC. Wu		
	Checked:			
DRAWING NO. : TFF-00046	Approval:		TOLERANCES ON	
	The first angle projection: 			DECIMALS
DESCRIPTION: TEST FIXTURE	Sheet 1 of 1		±0.20	±0.5°
	Scale: 1:1	Unit: mm		