

Travelling Merchant: \_\_\_\_\_

# DATASHEET

Standard: V754-A312-61.44MHz

P/N: 2PZ75NNM61440

Plot			The Label
Drew	Audited	Approved	Stamp, please! Thanks!
Date: 2020.05.09			

**Dongguan Dapu Telecom Technology Co.,Ltd**

Bldg16.N.Ind.Zone,SSL Industry Park, Dongguan City, Guangdong Province, China

TEL: 0086-0769-88010888 FAX: 0086-0769-81800098



## The Parameter of Product

MODEL: V754-A312-61.44MHz

### 1. Output

1.1. Frequency	61.44MHz
1.2. Waveform	HCMOS
	$V_{OH} \geq 90\%$ , $V_{OL} \leq 10\%$
1.3. Duty cycle	45%~55% @50%
1.4. Rise/Fall time(10%~90% )	$\leq 3ns$
1.5. Load	15pF

### 2. Frequency Stabilities

2.1. Tolerance vs. Temperature Range and voltage variance and first year aging.	$\leq 5 \times 10^{-5}$ @-40°C ~ +85°C ref. to 25°C
2.2. Initial Tolerance	$\leq \pm 2.0 \times 10^{-5}$ @25°C, VC=1.65V
2.3. Stability vs. Load	$\leq \pm 1.0 \times 10^{-6}$ @ $15 \times (1 \pm 0.05)$ pF
2.4. Aging	$\leq \pm 3.0 \times 10^{-6}$ / first year

### 3. Power Supply

3.1. Operating Voltage	$3.3 \times (1 \pm 0.05)$ Vdc
------------------------	-------------------------------

### 4. Current

4.1. Operating Current	30mA(Typical)
------------------------	---------------

### 5. Voltage Control Characteristics

5.1. Control Voltage = 0.3V	-80ppm~-180ppm
5.2. Control Voltage = 1.65 V	-20ppm~+20ppm
5.3. Control Voltage = 3.0V	+80ppm~+180ppm
5.4. Linearity	
5.5. Slope	Positive

### 6.. Phase Noise (Max)

6.1. 10Hz	-63dBc/Hz
6.2. 100Hz	-95dBc/Hz
6.3. 1KHz	-125dBc/Hz
6.4. 10KHz	-140dBc/Hz
6.5. 100KHz	-150dBc/Hz



7. Environmental Conditions

7.1. Operable Temperature Range

-40°C to +85°C

7.2. Storage Temperature Range

-55°C to +125°C

7.3. Vibration

Test Condition: 0.75mm ;acceleration:10g;50Hz~  
2000Hz, one cycle per 30 min, test 2 hour. (3 times for  
each 3 directions X , Y , Z)

7.4. Shock

100g; 11ms; half sine wave (3 times for each 3  
directions X , Y , Z ),IEC 68-2-27 Test Ea/Severity 50A.

7.5. Drop

Test Condition: free drop on steel-made surface or rigid  
planes from a height of 100cm,IEC 68-2-32.

8. Mechanical Structure(mm)

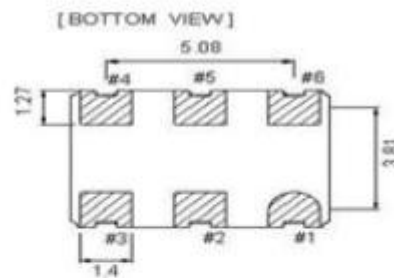
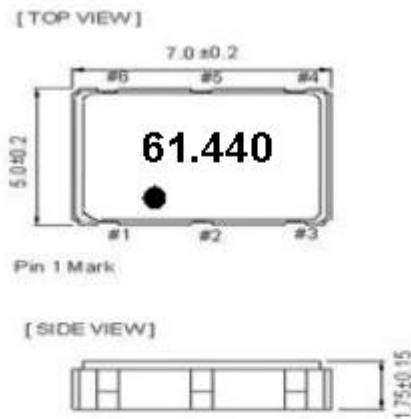

Pin	Function
#1	Vcon
#2	NC
#3	GND
#4	Output
#5	NC
#6	VDD

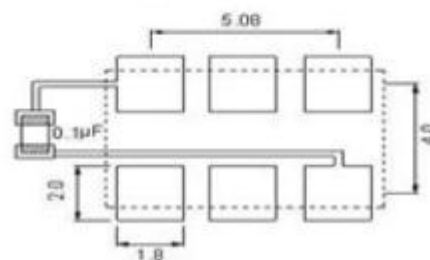

unit:mm



9. Suggested output load configuration

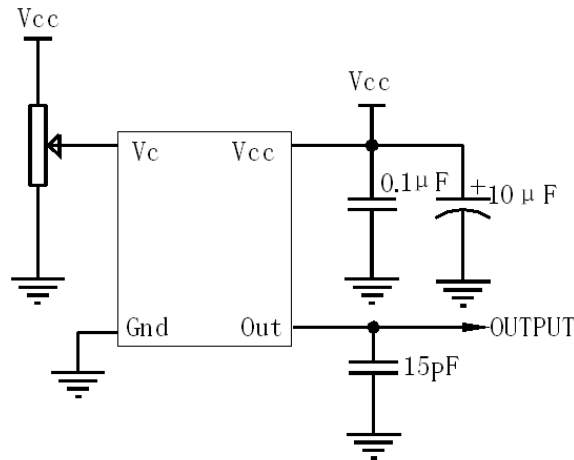

10. Reflow Soldering Curve (RoHS)

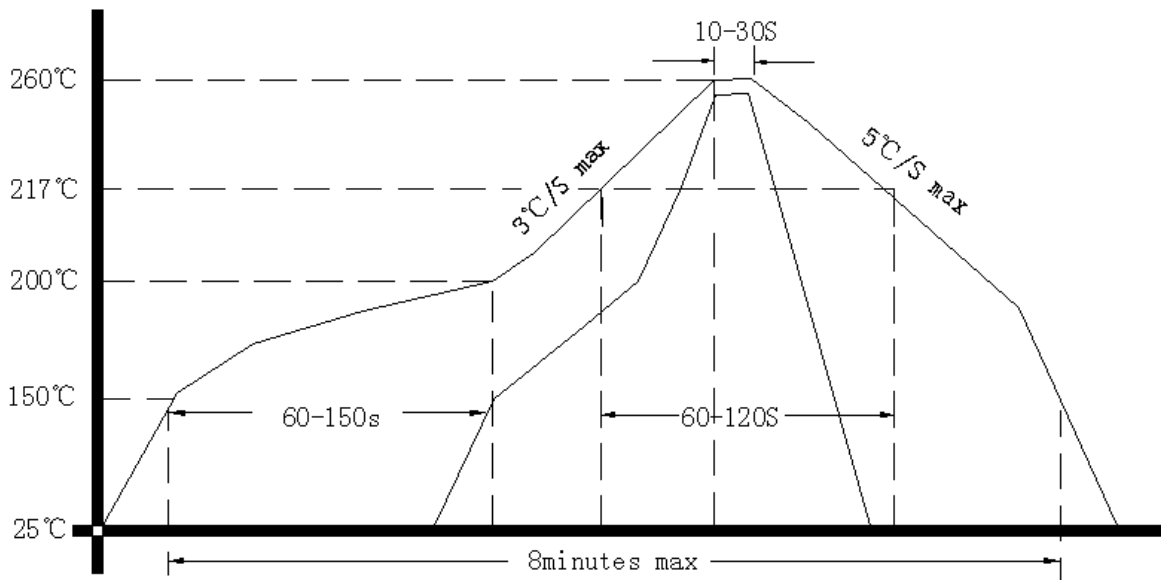

11. Package: Tape & Reel (mm)

