

Customer Code : _____

DATASHEET

DAPU P/N: DP7X2400009Y32NN24002/2PY32NN24002

Plot			The Label
Drew	Audited	Approved	Stamp, please! Thanks!
Date: 2017.04.13			

Guangdong Dapu Telecom Technology Co.,Ltd

Bldg16,.N.Ind.Zone,SSL Industry Park, Dongguan City, Guangdong Province, China

TEL: 0086-0769-88010888 FAX: 0086-0769-81800098



1、Electrical Parameters

MODEL: DP7X2400009							
No.	Parameters	SYM.	Electrical Spec.				Notes
			Min.	Typ.	Max.	Units	
1	Nominal Frequency	FL	24.00			MHz	
2	Output Waveform		LVCMOS				
3	Vdd		-0.5		4	V	
4	Supply Voltage		1.62	1.8	1.98	V	
5	Frequency Stability	F-stab	-25		+25	$\times 10^{-6}$	Inclusive of Initial tolerance at 25 °C, 1st year aging at 25 °C, and variations over operating temperature, rated power supply voltage and load.
6	Operating Temperature	T-opr	-40	~	+85	°C	
7	Storage Temperature	T-stg	-65	~	+150	°C	
8	Current Consumption	Icc	-	3.5	4.1	mA	
9	OE Disable Current	I_OD			4.0	mA	
10	Standby Current	I_std		0.2	1.3	μ A	
11	Rise/Full Time	Tr、Tf		1.3	2.5	ns	20%~80%
12	Duty Cycle	DC	45		55	%	
13	Output Voltage High	VOH	90%	-	-	Vdd	IOH =-2 mA
14	Output Voltage Low	VOL	-	-	10%	Vdd	IOL =2 mA
15	Input Voltage High	VIH	70%	-	-	Vdd	Pin 1 , OE
16	Input Voltage Low	VIL	-	-	30%	Vdd	Pin 1 , OE
17	Input Pull-up Impedence	Z_in	50	87	150	K Ω	Pin 1, OE logic high or logic low, or ST logic high
18	Start up Time	T_start	-	-	5	ms	Measured from the time Vdd reaches its rated minimum value
19	Enable/Disable Time	T_oe	-	-	130	ns	
20	Resume Time	T_resume			5	ms	
21	RMS Period Jitter	T_jitt	-	1.8	3	ps	
22	Peak to Peak Period Jitter	T_pk		14	30	ps	
23	Phase Jitter	T_phj	-	0.5	0.9	ps	Integration bandwidth = 900 kHz to 7.5 MHz
				1.3	2		Integration bandwidth =12kHz to 20MHz
24	Mechanical Shock		MIL-STD-883F,Method 2002				
	Mechanical Vibration		MIL-STD-883F,Method 2007				
	Temperature Cycle		JESD22, Method A104				
	Solderability		MIL-STD-883F,Method 2003				
	Moisture Sensitivity Level		MSL1 @260°C				



2、Mechanical Structure(mm)

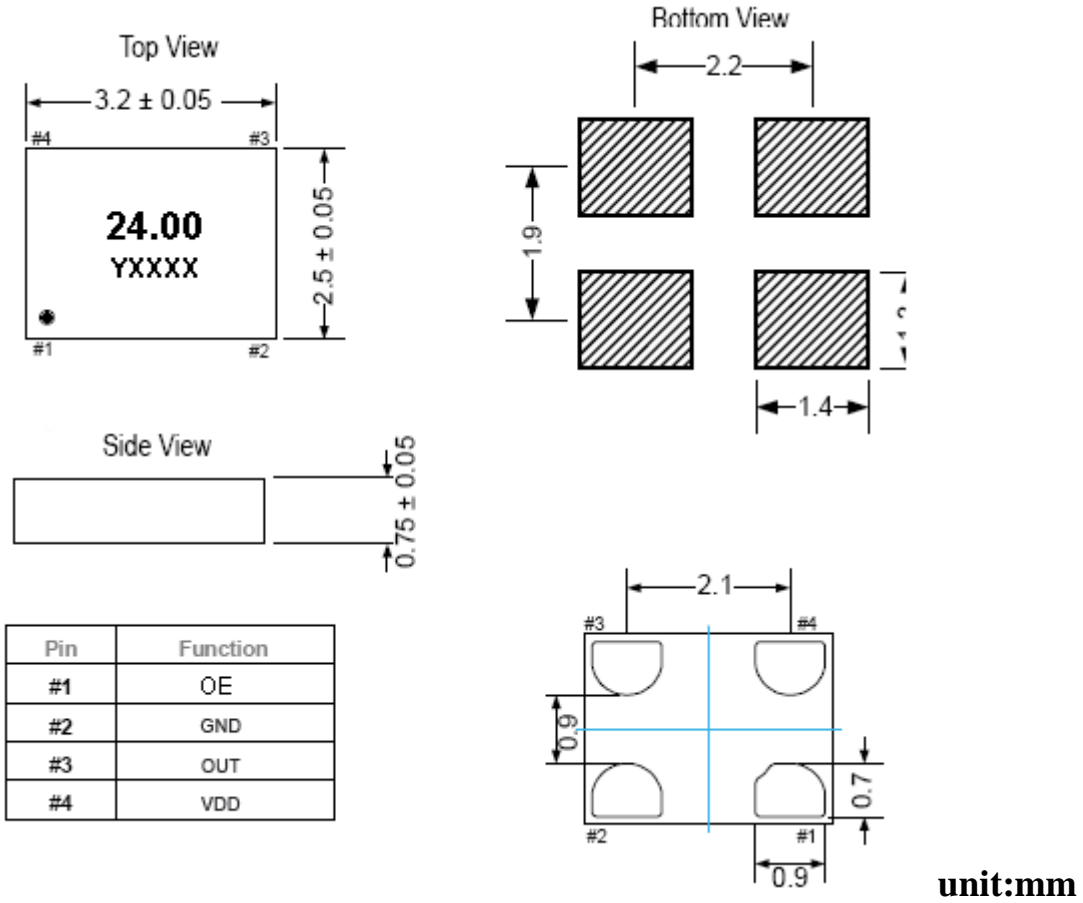

Note1: Tolerance ± 0.2 mm without mark

Note2: Referential weight 0.2g

Note3: Y denotes manufacturing origin and XXXX denotes manufacturing lot number. The value of “Y” will depend on the assembly location of the device

Note4: A capacitor of value 0.1μ F or higher between Vdd and GND is required.



3、 Test Circuit And Waveform

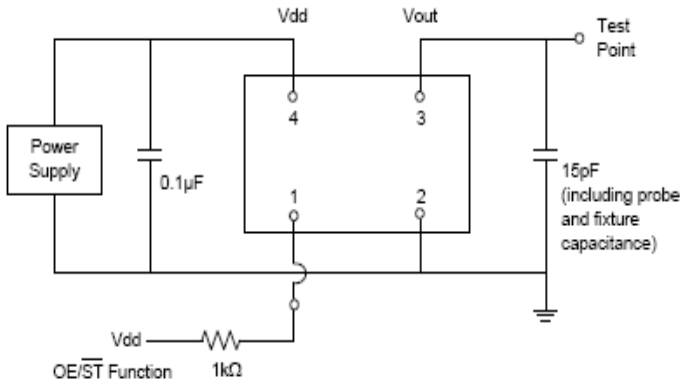

Figure 2. Test Circuit

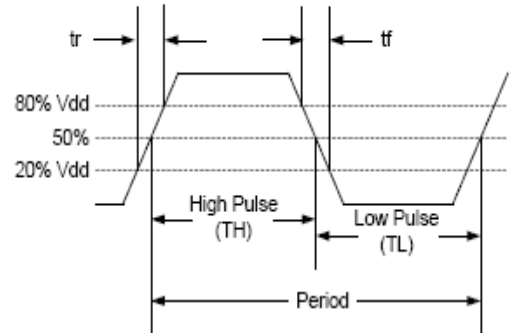
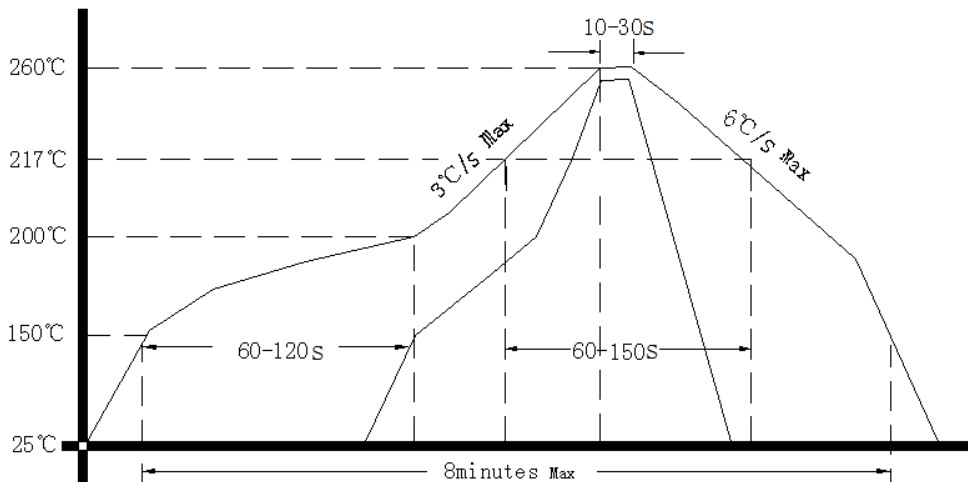

Figure 3. Waveform

4、 Reflow Soldering Curve (RoHS)



5、 Package: Tape & Reel (mm)

