





### Table of amendment

Version	Revision contents	Prepared by	Revised date
1.0	The first issued	<i>Amway</i>	2020.03.16



## 1、Electrical Parameters

MODEL: O22S-2107-12.80MHz							
Item	Description	Parameters			Unit	Test Condition	
		Min.	Typ.	Max.			
Output	Frequency	12.80			MHz		
	Output Waveform	HCMOS					
	Output Low Voltage			0.4	V	$V_{cc}=3.3V, O_{load}=15pF$	
	Output High Voltage	2.7			V	$V_{cc}=3.3V, O_{load}=15pF$	
	Duty Cycle	45	50	55	%	@50%	
	Rise / Fall Time (10%~90%)			10	ns		
	Load	15			pF		
Frequency Stabilities	Frequency Tolerance vs. Operating Temperature Range	-0.01		+0.01	$\times 10^{-6}$	$T_A$ varied from $-40^{\circ}C$ to $85^{\circ}C$ , measurement referenced to frequency observed with $f_{ref}=(f_{max}+f_{min})/2, V_{cc}=3.3V, O_{load}=15pF$ , temperature variable speed less than $2^{\circ}C$ per minute.	
	Initial Frequency Tolerance	-0.1		+0.1	$\times 10^{-6}$	Measurement referenced to frequency observed with $T_A = 25^{\circ}C, V_{cc}=3.3V$ , and after 15 minutes of operation, Within 24 hours after ex-works.	
	Frequency Tolerance vs. Supply Voltage	-3		+3	$\times 10^{-9}$	measurement referenced to frequency observed $T_A=25^{\circ}C, V_{cc}$ varied from 3.13V to 3.47V, and $O_{Load}=15pF$ .	
	Frequency Tolerance vs. Load	-3		+3	$\times 10^{-9}$	5% load change measurement referenced to frequency observed with $T_A=25^{\circ}C, V_{cc}=3.3V, O_{Load}=15pF$ .	
	Short-Term Stability: Allan Variance				0.08	$\times 10^{-9}$	Temperature stability, no EMI/EMC or other interference, test after power for 1hour ref. to $25^{\circ}C$ ; 10s.
					0.05	$\times 10^{-9}$	Temperature stability, no EMI/EMC or other interference, test after power for 1hour ref. to $25^{\circ}C$ ; 100s.
	Aging Tolerance Per Day	-1		+1	$\times 10^{-9}$	$V_{cc}, T_A$ constant measurement referenced to frequency observed with $T_A=25^{\circ}C, V_{cc}=3.3V$ , and after 30 days of operation.	
	Aging Tolerance 1 Year	-0.1		+0.1	$\times 10^{-6}$		
	Aging Tolerance 30 Days	-0.03		+0.03	$\times 10^{-6}$		
	Aging Tolerance 20 Years	-2		+2	$\times 10^{-6}$		



	Holdover 24hours Drift	-1		+1	$\times 10^{-9}$	$V_{cc}=3.3V$ , temperature change range $\pm 2.8^{\circ}C$ , after 30 days of operation.
	Overall Stability	-4.6		+4.6	$\times 10^{-6}$	Inclusive of the following: - operating temperature $-40^{\circ}C$ to $85^{\circ}C$ - $3.3V \pm 5\%$ - 15pF load $\pm 5\%$ - 2 times reflow soldering - 20 years aging reference to nominal frequency
Stratum 3E compliant per GR-1244-CORE teleconcordia						
Power Supply	Supply Voltage	3.13	3.3	3.47	V	
	Steady Consumption			400	mA	@ $25^{\circ}C$
	Warm-Up Time			5	minutes	@ $25^{\circ}C$ within $\pm 0.1 \times 10^{-6}$ of final frequency with reference after 1 hour on.
	Warm up current			900	mA	
Phase Noise	Phase Noise		-120	-110		10Hz
			-140	-130		100Hz
			-145	-140		1KHz
			-150	-145		10KHz
			-150	-145		100KHz
Environmental Conditions	Operable Temperature	-40		+85	$^{\circ}C$	
	Storage Temperature	-55		+105	$^{\circ}C$	
	ESD Level	Human Body Model,class2: 2000V to 4000V; ANSI/ESDA/JEDEC JS-001-2010.				
		Machine Model, class B: 200V to 400V; JEDEC JESD22-A115C.				
	Moisture Sensitivity Level	Level 3.				
	Vibration	Test Condition: 0.75mm ;acceleration:10g;10Hz~500Hz, one cycle per 30 min, test 2 hour. (3 times for each 3 directions X , Y , Z), IEC 68-2-06 Test Fc.				
Shock	50g; 11ms; half sine wave (3 times for each 3 directions X , Y , Z ),IEC 68-2-27 Test Ea/Severity 50A.					
Full Package Storage	Relative humidity (%)	20% ~70%				
	Temperature ( $^{\circ}C$ )	-10~35 $^{\circ}C$				



## 2、Mechanical Structure(mm)

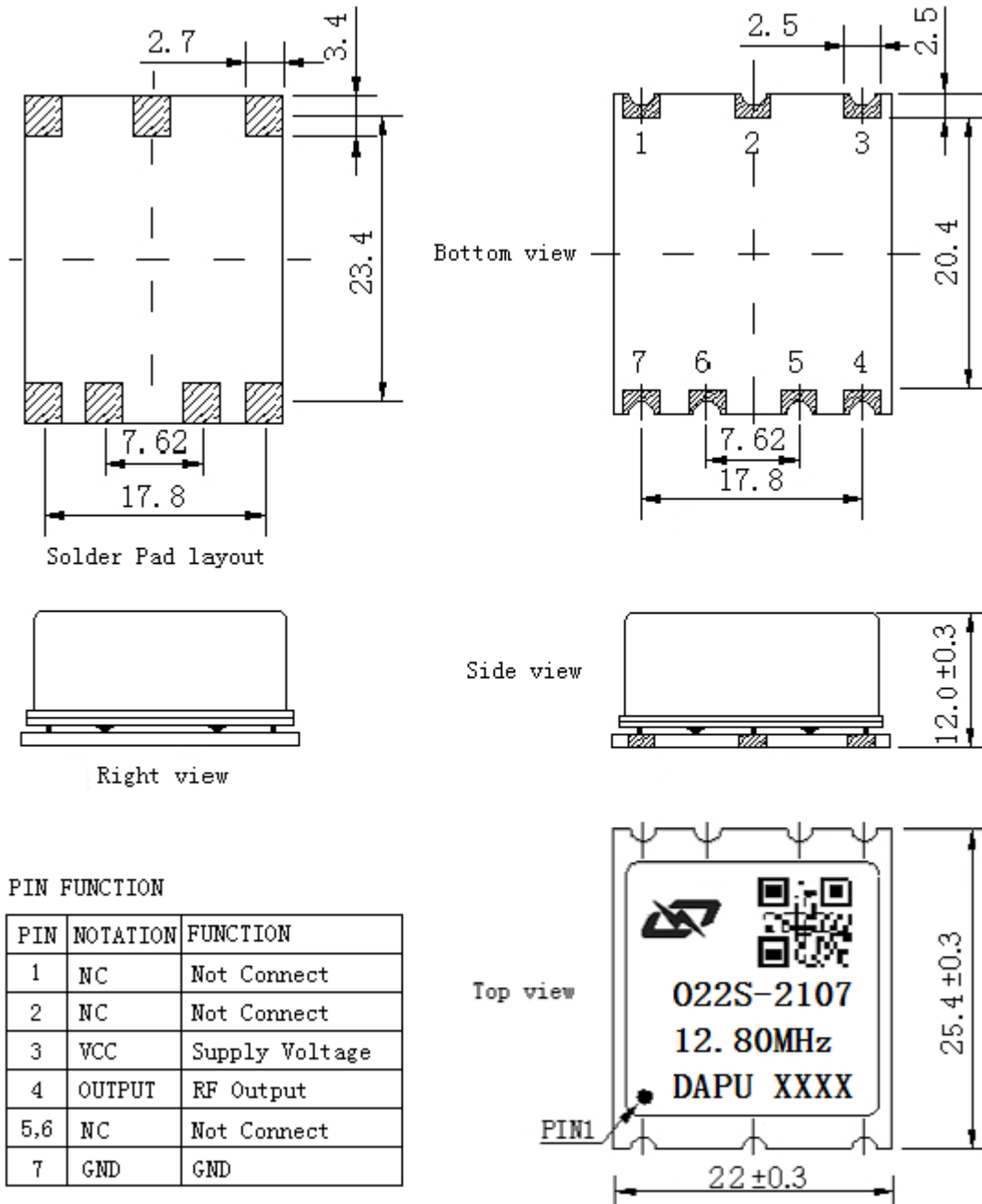

- Note1:** Tolerance  $\pm 0.2\text{mm}$  without mark
- Note2:** Referential weight 7.8g
- Note3:** NC is not connect
- Note4:** The first two xx representative: week  
After two xx representative: year
- Note5:** Washable.



### 3、 Test Circuit

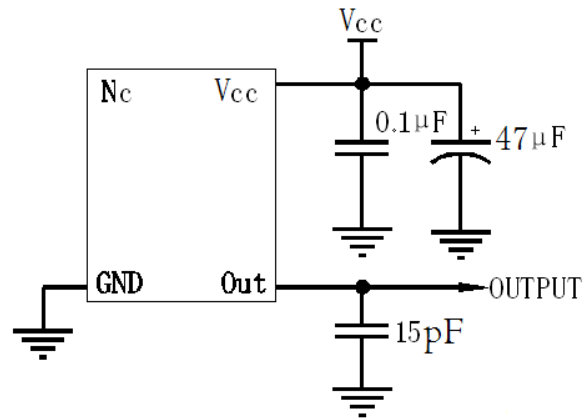

### 4、 Reflow Soldering Curve (RoHS)

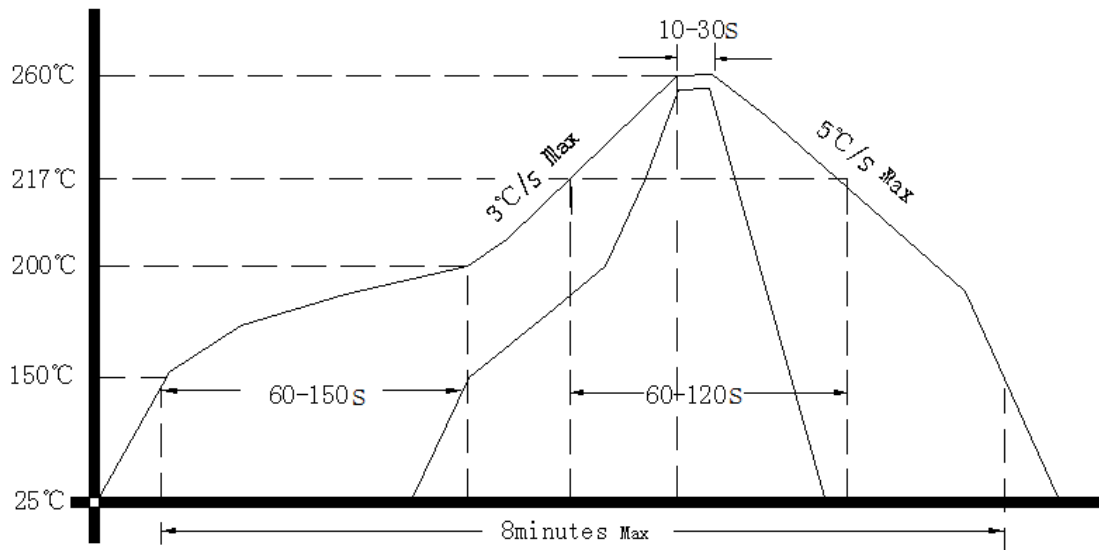

### 5、 Package (mm)

