

Travelling Merchant: _____

DATASHEET

Standard: **V756-D313-122.88MHz** P/N: **Z75YM12281**

Plot			The Label
Drew	Audited	Approved	Stamp, please! Thanks!
<i>Amway.wei</i>	<i>Tina.Tang</i>	<i>James.Liu</i>	
Date: 2014.07.21			

Guangdong Dapu Telecom Technology Co.,Ltd

Bldg13-16,.N.Ind.Zone,SSL Industry Park, Dongguan City, Guangdong Province, China

TEL: 0086-0769-88010888 FAX: 0086-0769-81800098



Table of amendment

Version	Revision contents	Prepared by	Revised date
1.0	The first issued	<i>Amway</i>	2014.07.21



1. Electrical Parameters

MODEL: V756-D313-122.88MHz						
Item	Description	Parameters			Unit	Test Condition
		Min.	Typ.	Max.		
Output	Frequency	122.88			MHz	
	Output Waveform	HCMOS				
	Output Low Voltage			$0.1V_{cc}$	V	$V_{cc}=3.3V, O_{load}=15\text{ pF}$
	Output High Voltage	$0.9V_{cc}$			V	$V_{cc}=3.3V, O_{load}=15\text{ pF}$
	Duty Cycle	45	50	55	%	@50%
	Rise / Fall Time (10%~90%)			3	ns	@25°C
	Load	15			pF	
	Period Jitter			1	ps	RMS (12KHz~20MHzBW)
	Start-up Time			1	ms	To 90% of final amplitude
Frequency Stabilities	Frequency Tolerance vs. Operating Temperature Range	-20		+20	$\times 10^{-6}$	T_A varied from -40°C to 85°C, measurement referenced to frequency observed with $T_A=25^\circ\text{C}, V_{cc}=3.3V, V_c=1.65V, O_{load}=15\text{pF}$, temperature variable speed less than 2°C per minute.
	Initial Frequency Tolerance	-20		+20	$\times 10^{-6}$	Measurement referenced to frequency observed with $T_A=25^\circ\text{C}, V_{cc}=3.3V, V_c=1.65V$ within 30 days after ex-works.
	Aging Tolerance 1 Year	-5		+5	$\times 10^{-6}$	$T_A=25^\circ\text{C}, V_{cc}=3.3V$, and after 1h of operation.
	Aging Tolerance 15 Years	-15		+15	$\times 10^{-6}$	
Power Supply	Current Consumption			40	mA	@25°C, $V_{cc}=3.3V, V_c=1.65V, O_{load}=15\text{pF}$.
	Supply Voltage	3.13	3.3	3.47	V	



Voltage Control Characteristics	Control Voltage	0		3.3	V	
	Absolute Pull Range			-50	$\times 10^{-6}$	
		+50			$\times 10^{-6}$	
	Linearity			10	%	
	Slope	Positive				
	Input Impedance	2	5		M Ω	
Modulation BW	15	20		KHz		
Phase Noise	Phase Noise		-65		dBc/Hz	10Hz
			-95			100Hz
			-124			1KHz
			-139			10KHz
			-150			100KHz
Environmental Conditions	Operable Temperature	-40		+85	$^{\circ}\text{C}$	
	Storage Temperature	-55		+125	$^{\circ}\text{C}$	
	ESD Level	Human Body Model, class2: 2000V to 4000V; ANSI/ESDA/JEDEC JS-001-2010.				
		Machine Model, class B: 200V to 400V; ANSI/ESDA/JEDEC JS-001-2010.				
	Moisture Sensitivity Level	Level 2.				
	Vibration	Test Condition: 0.75mm; acceleration:10g;10Hz~2000Hz, one cycle per 30 min, test 2 hour. (3 times for each 3 directions X , Y , Z) .IEC 68-2-06 Test Fc.				
Shock	100g; 6ms; half sine wave (3 times for each 3 directions X , Y, Z),IEC 68-2-27 Test Ea/Severity 50A.					



2. Mechanical Structure(mm)

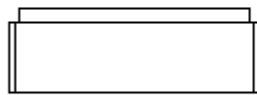
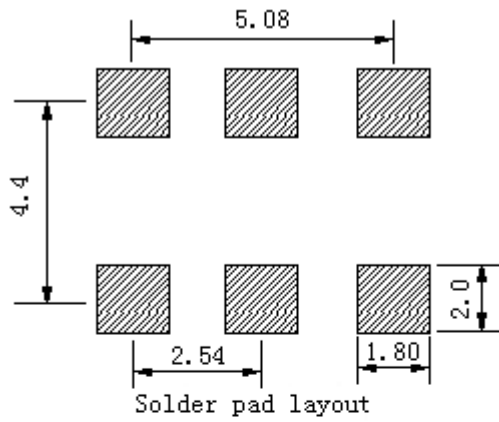

PIN FUNCTION

PIN	FUNCTION
1	VC
2	E/D
3	GND
4	OUTPUT
5	NC
6	VCC

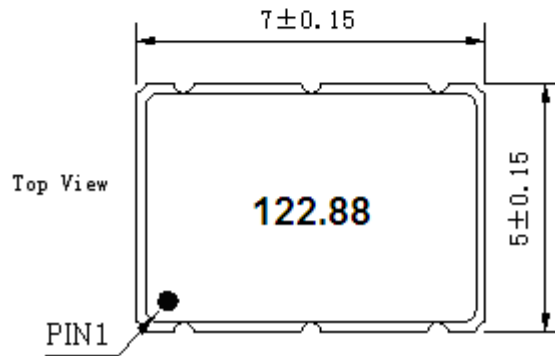
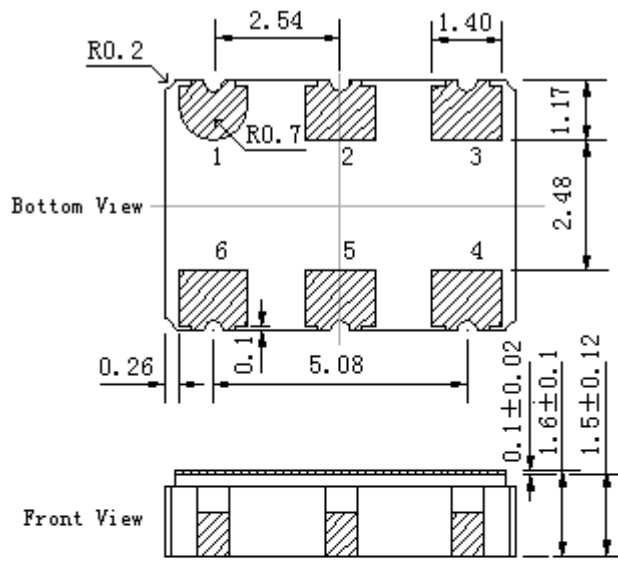

Note1: Tolerance $\pm 0.1\text{mm}$ without mark

Note2: Referential Weight 0.3g

Note3: Disable: $V_{il} \leq 0.1 V_{cc}$
 Enable: $V_{ih} \geq 0.9 V_{cc}$

E/D	OUT
high level, open	data
low level	no data



3. Test circuit

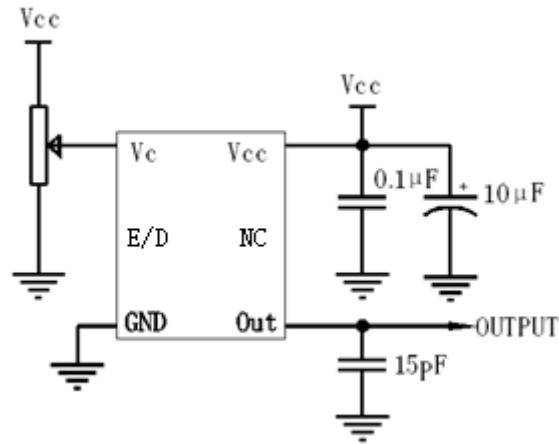

4. Reflow Soldering Curve (RoHS)

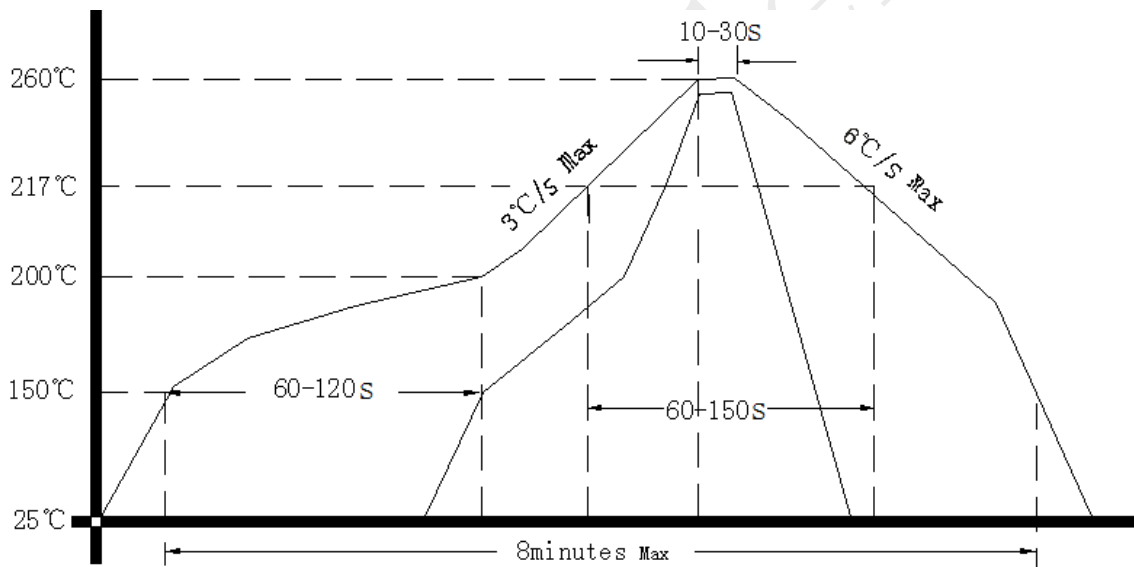

5. Package: Tape & Reel (mm)

