

Travelling Merchant: _____

DATASHEET

Standard: **O11H-E319-38.88MHz**

P/N: _____

Plot			The Label
Drew	Audited	Approved	Stamp, please! Thanks!
Date: 2019.12.19			

Guangdong Dapu Telecom Technology Co.,Ltd

Bldg13-16,.N.Ind.Zone,SSL Industry Park, Dongguan City, Guangdong Province, China

TEL: 0086-0769-88010888 FAX: 0086-0769-81800098



1. Electrical Parameters

MODEL: O11H-E319-38.88MHz						
Item	Description	Parameters			Unit	Test Condition
		Min.	Typ.	Max.		
Output	Frequency	38.88			MHz	
	Output Waveform	LVCMOS				
	Output Low Voltage			0.4	V	$V_{cc}=3.3V, O_{load}=15pF$
	Output High Voltage	2.4			V	$V_{cc}=3.3V, O_{load}=15pF$
	Duty Cycle	45		55	%	@50%
	Rise / Fall Time			6	ns	10%~90%
	Operating Life	15			year	
	Load	13.5	15	16.5	pF	
Frequency Stabilities	Frequency Tolerance vs. Operating Temperature Range	-0.01		+0.01	$\times 10^{-6}$	T_A varied from $-40^{\circ}C$ to $85^{\circ}C$, measurement referenced to frequency observed with $f_{ref}=(f_{max}+f_{min})/2, V_{cc}=3.3V, O_{load}=15pF$, temperature variable speed less than $2^{\circ}C$ per minute.
	Frequency Accuracy	-0.4		+0.4	$\times 10^{-6}$	Within 90 days after shipment and 15 minutes warm up time (before reflow), Measurement referenced to nominal frequency
		-0.4		+0.4	$\times 10^{-6}$	Within 90 days after shipment and 15 minutes warm up time (after reflow), Measurement referenced to nominal frequency.
	Warm Up1	-0.1		+0.1	$\times 10^{-6}$	After warm up 5 minute, Measurement referenced to frequency observed with $T_A=25^{\circ}C, V_{cc}=3.3V$, and after 1H of operation.
	Warm Up2	-0.1		+0.1	$\times 10^{-6}$	After warm up 1H, Measurement referenced to frequency observed with $T_A=25^{\circ}C, V_{cc}=3.3V$, and after 24H of operation.
	Frequency Tolerance vs. Supply Voltage	-5		+5	$\times 10^{-9}$	measurement referenced to frequency observed $T_A=25^{\circ}C, V_{cc}$ varied from 3.15V to 3.45V, and $O_{Load}=15pF$.
	Frequency Tolerance vs. Load	-5		+5	$\times 10^{-9}$	10% load change measurement referenced to frequency observed with $T_A=25^{\circ}C, V_{cc}=3.3V$, and $O_{Load}=15pF$.
	Short-Term Stability: Allan Variance			0.05	$\times 10^{-9}$	Temperature stability, no EMI\EMC or other interference, test after power for 1hour ref. to $25^{\circ}C$; 1s.
			0.2	$\times 10^{-9}$	Temperature stability, no EMI\EMC or other interference, test after power for 1hour ref. to $25^{\circ}C$; 100s.	



	Jitter			0.9	ps	RMS Jitter (12KHz-20MHz)
	Aging Tolerance Per Day	-2		+2	$\times 10^{-9}$	V_{cc} , V_c , T_A constant measurement referenced to frequency observed with $T_A=25^\circ\text{C}$, $V_{cc}=3.3\text{V}$, and after 30 days of operation.
	Aging Tolerance 1 Year	-0.2		+0.2	$\times 10^{-6}$	
	Aging Tolerance 10 Year	-1		+1	$\times 10^{-6}$	
Power Supply	Supply Voltage	3.13	3.3	3.47	V	
	Steady Consumption			300	mA	@25°C
	Warm up current			750	mA	
	Warm up time			5	min	
	Start up time			100	ms	90% VCC to the correct frequency output time
Phase Noise	Phase Noise		-105	-95	dBc/Hz	10Hz
			-135	-125		100Hz
			-150	-145		1KHz
			-159	-154		10KHz
			-160	-155		100KHz
			-162	-157		1MHz
Environmental Conditions	Operable Temperature	-40		+85	°C	
	Storage Temperature	-55		+125	°C	
	ESD Level	Human Body Model, class2: 2000V to 4000V; ANSI/ESDA/JEDEC JS-001-2010.				
		Machine Model, class B: 200V to 400V; ANSI/ESDA/JEDEC JS-001-2010.				
	Moisture Sensitivity Level	Level 2.				
	Vibration	Test Condition: 0.75mm ;acceleration:10g;10Hz~500Hz, one cycle per 30 min, test 2 hour. (3 times for each 3 directions X , Y , Z), IEC 68-2-06 Test Fc.				
Shock	50g; 11ms; half sine wave (3 times for each 3 directions X, Y, Z), IEC 68-2-27 Test Ea/Severity 50A.					
Full Package Storage	Relative humidity (%)	20%~70%				
	Temperature (°C)	-10~35°C				



2. Mechanical Structure (mm)

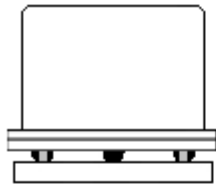
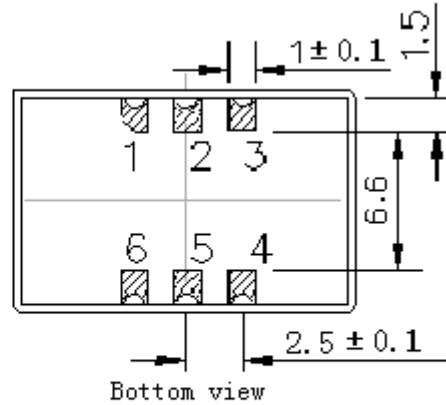

PIN FUNCTION

PIN	NOTATION	FUNCTION
1	NC	Not Connect
2,5	NC	Not Connect
3	GND	GND
4	OUTPUT	RF Output
6	VCC	Supply Voltage



- Note1:** Tolerance $\pm 0.20\text{mm}$ without mark
- Note2:** The first two xx representative: year
After two xx representative: week
- Note3:** Referential weight 2.6g
- Note4:** NC is not connect



3. Test Circuit

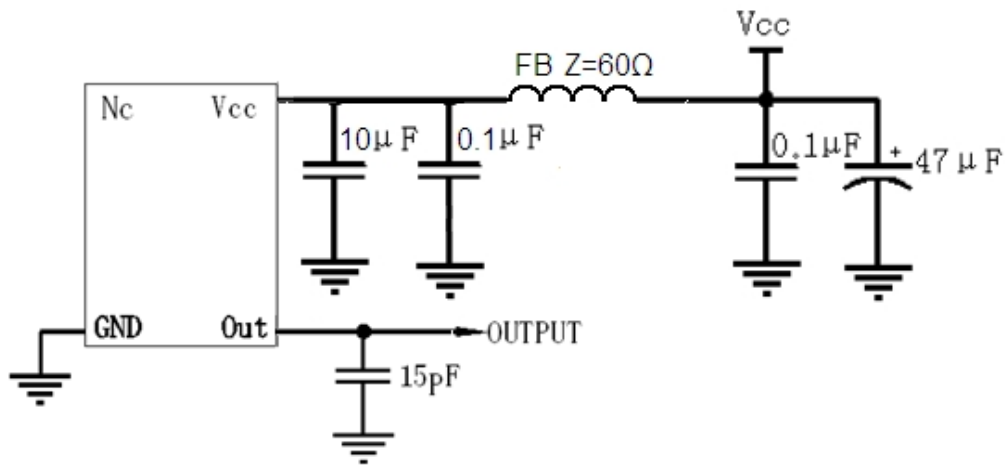

4. Reflow Soldering Curve (RoHS)

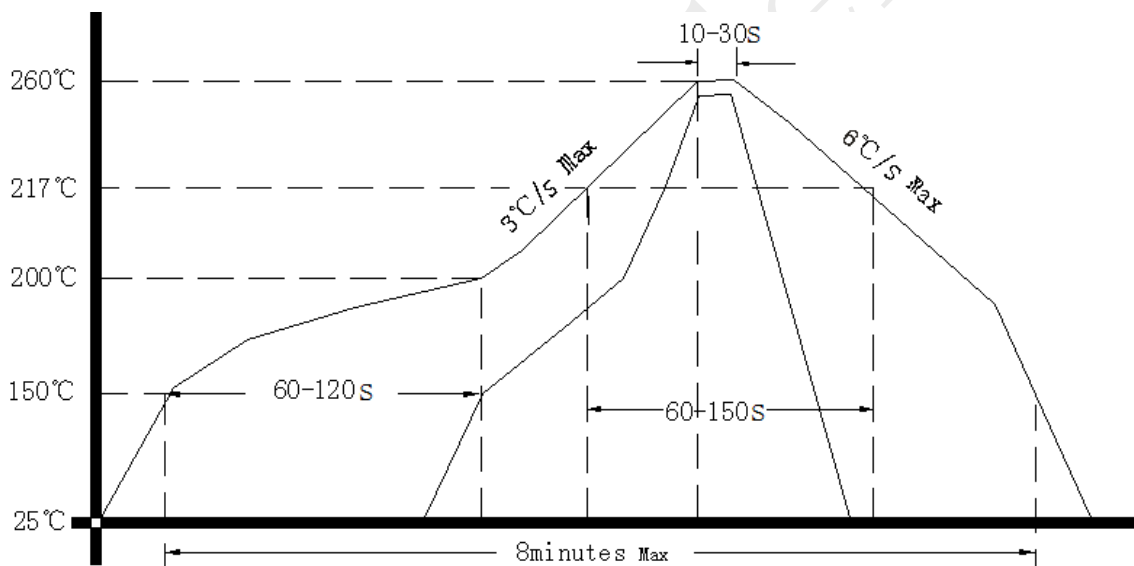

5. Package: Tape & Reel (mm)

