

Customer Code : _____

DATASHEET

DAPU P/N: 023B-0345-16.384MHz

Customer P/N: _____

DAPU			Customer Approval
Drew	Audited	Approved	Stamp, please! Thanks!
Date: 2020.09.07			

Guangdong Dapu Telecom Technology Co.,Ltd

Bldg 16,.N.Ind.Zone,SSL Industry Park, Dongguan City, Guangdong Province, China

TEL: 0086-0769-88010888 FAX: 0086-0769-81800098



1. Electrical Parameters

MODEL: O23B-O345-16.384MHZ						
Item	Description	Parameters			Unit	Test Condition
		Min.	Typ.	Max.		
Output	Frequency	16.384			MHz	
	Output Waveform	HCMOS				
	Output Low Voltage			0.4	V	$V_{cc}=12.0V, O_{load}=15pF$
	Output High Voltage	3.5			V	$V_{cc}=12.0V, O_{load}=15pF$
	Duty Cycle	45	50	55	%	@50%
	Rise / Fall Time (10%~90%)			5	ns	
	Spurious Suppression			-70	dBc	
	Load	15			pF	
Frequency Stabilities	Frequency Tolerance vs. Operating Temperature Range	-2		+2	$\times 10^{-9}$	T_A varied from $-40^{\circ}C$ to $75^{\circ}C$, measurement referenced to frequency observed with $f_{ref}=(f_{max}+f_{min})/2, V_{cc}=12.0V, O_{load}=15pF$, temperature variable speed less than $2^{\circ}C$ per minute.
	Initial Frequency Accuracy	-0.1		+0.1	$\times 10^{-6}$	Power on within 5 minutes, $V_{cc}=12.0V$,
	Initial Frequency Tolerance	-0.01		0.01	$\times 10^{-6}$	Frequency drift after power on 10min against 1hour.
	Frequency Tolerance vs. Load	-0.5		+0.5	$\times 10^{-9}$	10% load change measurement referenced to frequency observed with $T_A=25^{\circ}C, V_{cc}=12.0V$, and $O_{Load}=15pF$.
	Retrace	-5		+5	$\times 10^{-9}$	After 24 hour off at $25^{\circ}C$ 2 hours power on
	Aging Tolerance Per Day	-0.07		+0.07	$\times 10^{-9}$	V_{cc}, V_c, T_A constant measurement referenced to frequency observed with $T_A=25^{\circ}C, V_{cc}=12.0V, V_c=2.5V$, and after 30 days of operation.
	Aging Tolerance Per month	-2.0		+2.0	$\times 10^{-9}$	
	Aging Tolerance The first year	-12.0		+12.0	$\times 10^{-9}$	



Power Supply	Supply Voltage	5		12	V	
	Steady Consumption			300	mA	@25°C
	Warm up current			750	mA	
Phase Noise	Phase Noise		-120		dBc/Hz	10Hz
			-140			100Hz
			-152			1KHz
			-155			10KHz
Environmental Conditions	Operating Temperature	-40		+75	°C	
	Storage Temperature	-55		+90	°C	
	ESD Level	Human Body Model, class2: 2000V to 4000V; ANSI/ESDA/JEDEC JS-001-2010.				
		Machine Model, class B: 200V to 400V; JEDEC JESD22-A115C.				
	Moisture Sensitivity Level	Not humidity sensitive.				
	Vibration	Test Condition: 0.75mm ;acceleration:10g;10Hz~500Hz, one cycle per 30 min, test 2 hour. (3 times for each 3 directions X , Y , Z), IEC 68-2-06 Test Fc.				
Shock	50g; 11ms; half sine wave (3 times for each 3 directions X, Y, Z), IEC 68-2-27 Test Ea/Severity 50A.					
Full Package Storage	Relative humidity (%)	20%~70%				
	Temperature (°C)	-10~35°C				



2. Mechanical Structure (mm)

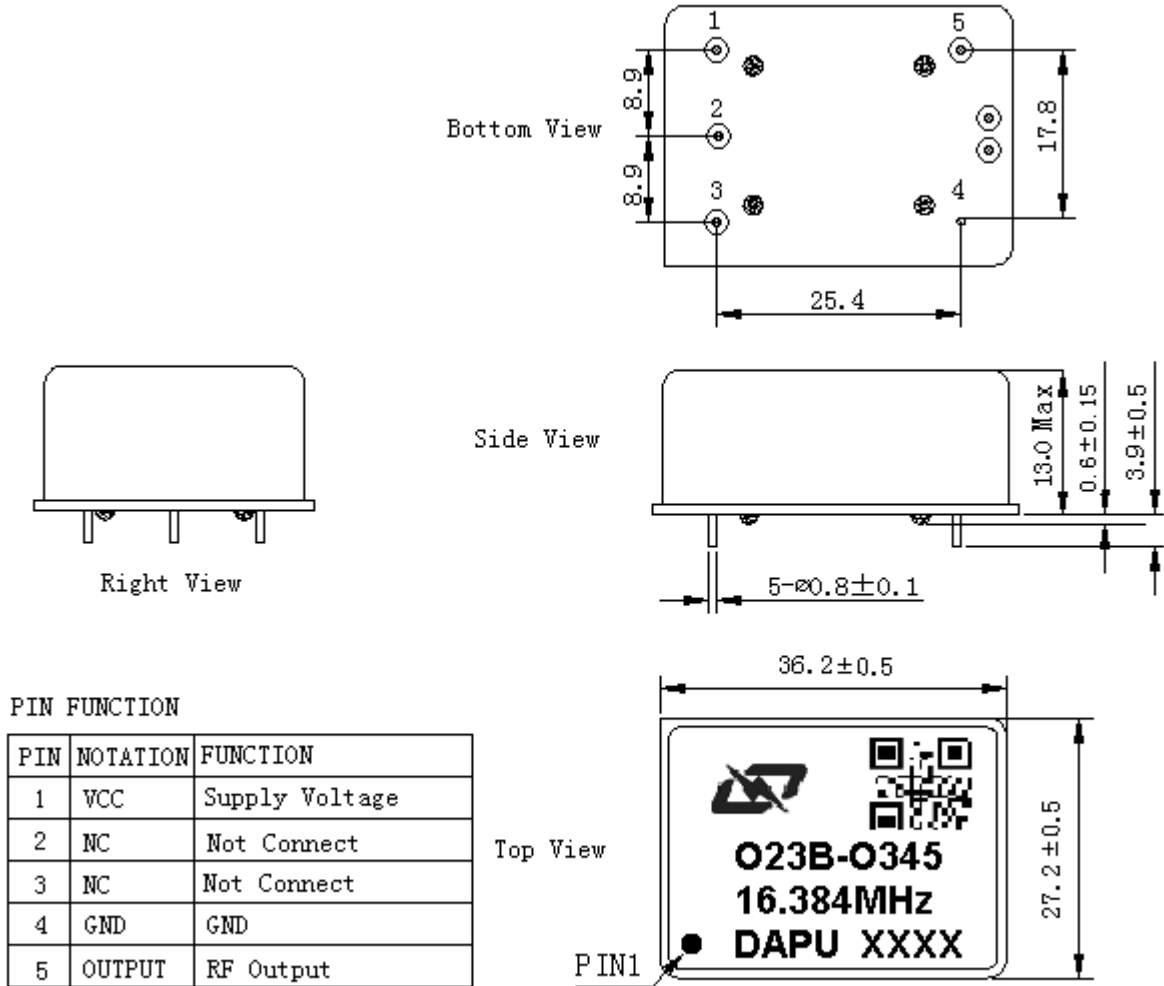

- Note1:** Tolerance ±0.20mm without mark
- Note2:** The first two xx representative: week
After two xx representative: year
- Note3:** Referential weight 20.7g
- Note4:** NC is not connect



3. Test Circuit

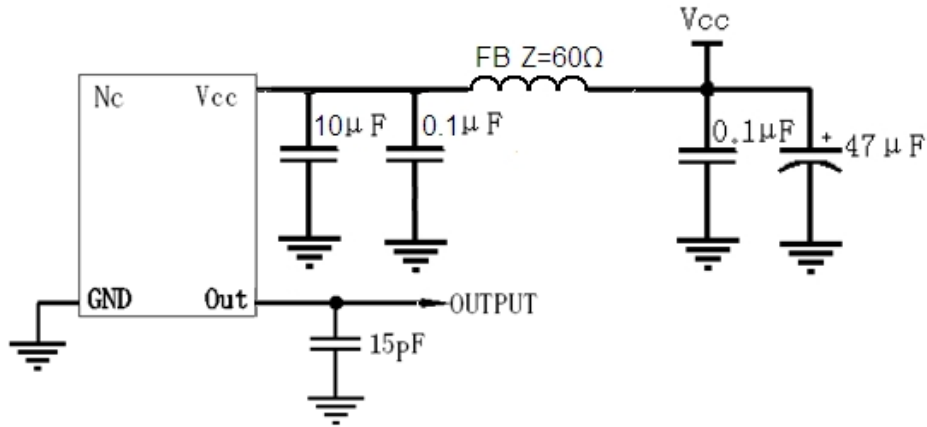

4. Reflow Soldering Curve (RoHS)



5. Package (mm)

