

Travelling Merchant: _____

DATASHEET

Standard: DP7X25000007Y32NN250011

Plot			The Label
Drew	Audited	Approved	Stamp, please! Thanks!
Date: 2014.07.17			

Guangdong Dapu Telecom Technology Co.,Ltd

Bldg13,.N.Ind.Zone,SSL Industry Park, Dongguan City, Guangdong Province, China

TEL: 0086-0769-88010888 FAX: 0086-0769-81800098



1、Electrical Parameters

MODEL: DP7X2500007							
No.	Parameters	SYM.	Electrical Spec.				Notes
			Min.	Typ.	Max.	Units	
1	Nominal Frequency	FL	25.00			MHz	
2	Frequency Stability	-	-50		+50	$\times 10^{-6}$	Incl.25°C tolerance, tolerance over operating temperature range, input Voltage change, load change,1 year aging
3	Operating Temperature	Topr	-20	~	+70	°C	
4	Storage Temperature	Tstg	-55	~	+125	°C	
5	Supply Voltage	VDD	3.3±10%			V	
6	Input Current	Icc	-	-	11	mA	
7	Enable Control	-	Yes			-	Pad 1
8	Output Load: CMOS	CL	15			pF	
9	Aging	-	-3	-	+3	$\times 10^{-6}/\text{yr.}$	1st. Year at 25°C
10	Output Voltage High	VoH	90% Vdd	-	-	V	
11	Output Voltage Low	Vol	-	-	10% Vdd	V	
12	Rise Time	Tr	-	-	5	ns	10%-90% VDD Level
13	Fall Time	Tf	-	-	5	ns	90%-10% VDD Level
14	Symmetry (Duty ratio)	TH/T	45	~	55	%	
15	Start-up Time	Tosc	-	-	10	ms	
16	Enable Voltage High	Vhi	70% Vdd	-	-	V	
17	Disable Voltage Low	Vlo	-	-	30% Vdd	V	
18	ESD Level	Human Body Model,class2: 2000V to 4000V; ANSI/ESDA/JEDEC JS-001-2010.					
		Machine Model, class B: 200V to 400V; ANSI/ESDA/JEDEC JS-001-2010.					
19	Moisture Sensitivity Level	Level 2.					
20	Vibration	Test Condition: 0.75mm ;acceleration:10g;10Hz~2000Hz, one cycle per 30 min, test 2 hour. (3 times for each 3 directions X , Y , Z).IEC 68-2-06 Test Fc.					
21	Shock	100g; 6ms; half sine wave (3 times for each 3 directions X , Y , Z),IEC 68-2-27 Test Ea/Severity 50A.					



2、Mechanical Structure(m

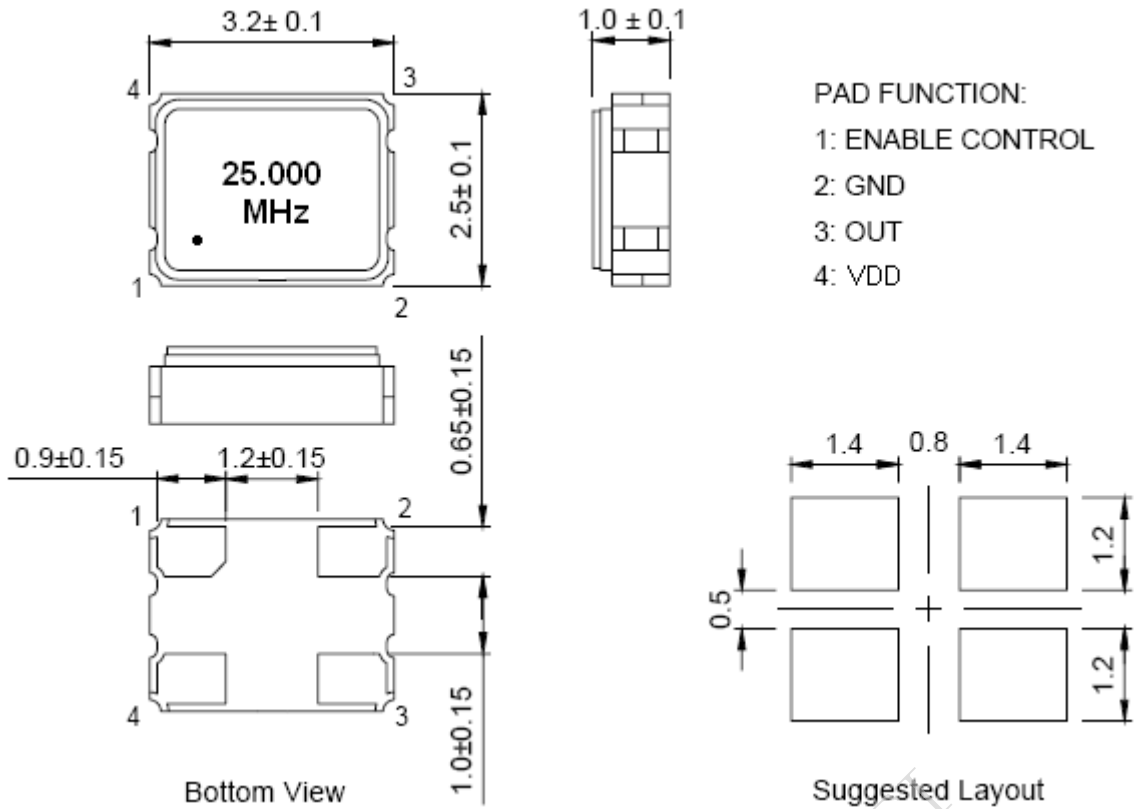

Note1: Tolerance $\pm 0.2\text{mm}$

3、Test Diagram

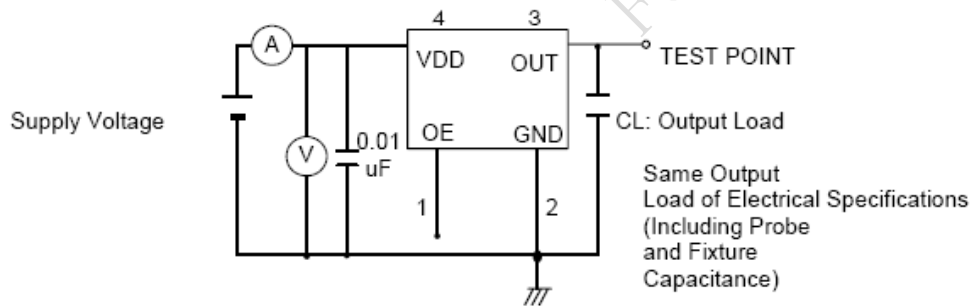

Control input (output enable/disable)
 Logic 1 or open on pad 1: Oscillator output
 Logic 0 on pad 1 : Disable output to high impedance



4、 Reflow Soldering Curve (RoHS)

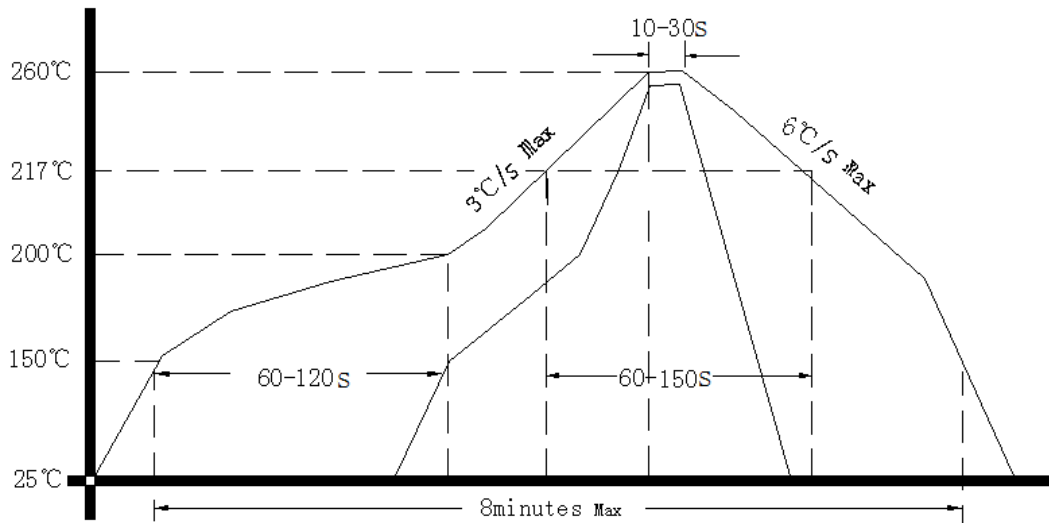

5、 Package: Tape & Reel (mm)

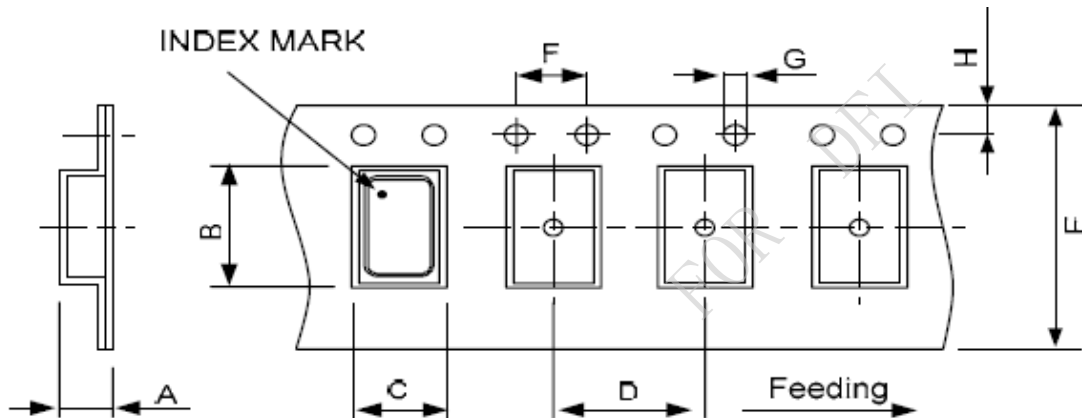

DIMENSIONS	A	B	C	D	E	F	G	H	(UNIT : mm)
	2.30	7.90	5.45	8.00	16.00	4.00	1.50	1.75	

REMARK :

