

Travelling Merchant: _____

DATASHEET

Standard: **O44A-K446-10.00MHz**

P/N: _____

Plot			The Label
Drew	Audited	Approved	Stamp, please! Thanks!
<i>Amway.wei</i>	<i>Tony · Wang</i>	<i>James.Liu</i>	
Date: 2019.06.27			

Guangdong Dapu Telecom Technology Co.,Ltd

Bldg13-16,.N.Ind.Zone,SSL Industry Park, Dongguan City, Guangdong Province, China

TEL: 0086-0769-88010888 FAX: 0086-0769-81800098



1. Electrical Parameters

MODEL: O44A-K446-10.00MHZ						
Item	Description	Parameters			Unit	Test Condition
		Min.	Typ.	Max.		
Output	Frequency	10.00			MHz	
	Output Waveform	Sine wave				
	Level	7			dBm	
	Load	50			Ω	
	Harmonics Suppression			-30	dBc	
	Spurious Suppression			-70	dBc	
Frequency Stabilities	Frequency Tolerance vs. Operating Temperature Range	-5		+5	$\times 10^{-9}$	T_A varied from -20°C to 70°C , measurement referenced to frequency observed with $f_{\text{ref}}=(f_{\text{max}}+f_{\text{min}})/2$, $V_{\text{cc}}=12.0\text{V}$, $V_c=2.5\text{V}$, $O_{\text{load}}=50\Omega$, temperature variable speed less than 2°C per minute.
	Initial Frequency Tolerance	-0.1		+0.1	$\times 10^{-6}$	Measurement referenced to frequency observed with $T_A=25^{\circ}\text{C}$, $V_{\text{cc}}=12.0\text{V}$, $V_c=2.5\text{V}$ and after 15 minutes of operation, within 30 days after ex-works.
	Frequency Tolerance vs. supply voltage	-5		+5	$\times 10^{-9}$	measurement referenced to frequency observed $T_A=25^{\circ}\text{C}$, V_{cc} varied from 11.4V to 12.6V, $V_c=2.5\text{V}$, $O_{\text{load}}=50\Omega$.
	Frequency Tolerance vs. Load	-5		+5	$\times 10^{-9}$	5% Load Change Measurement referenced to frequency observed with $T_A=25^{\circ}\text{C}$, $V_{\text{cc}}=12.0\text{V}$, $V_c=2.5\text{V}$, $O_{\text{load}}=50\Omega$.
	Short Term Stability			0.01	$\times 10^{-9}$	Temperature stability, no EMI\EMC or other interference, test after power for 1hour ref. to 25°C ; 1s, using PN9000 equipment.
	Aging Tolerance per day	-0.5		+0.5	$\times 10^{-9}$	V_{cc}, V_c, T_A constant Measurement referenced to frequency observed with $T_A=25^{\circ}\text{C}$, $V_{\text{cc}}=12.0\text{V}$, $V_c=2.5\text{V}$, $O_{\text{load}}=50\Omega$ and after 30 days of operation.
	Aging Tolerance 1 Year	-0.05		+0.05	$\times 10^{-6}$	
Power Supply	Supply Voltage	11.4	12.0	12.6	V	
	Current Consumption			150	mA	@ 25°C
	Current Consumption during warm up			400	mA	



Voltage Control Characteristics	Frequency Tuning Range			-0.5	$\times 10^{-6}$	$V_c=0V$. measurement referenced to $V_c=2.5V$.
		-0.1		+0.1	$\times 10^{-6}$	$V_c=2.5V$. measurement referenced to exactly 10.00MHz.
		+0.5			$\times 10^{-6}$	$V_c=5.0V$. measurement referenced to $V_c=2.5V$.
	Linearity			10	%	
	Slope	Positive				
	Input Impedance	100				K Ω
Phase Noise	Phase Noise @25°C			-125	dBc/Hz	10Hz
				-145		100Hz
				-150		1KHz
				-150		10KHz
				-155		100KHz
Environmental Conditions	Operable Temperature	-20		+70	°C	
	Storage Temperature	-55		+85	°C	
	ESD Level	Human Body Model, class2: 2000V to 4000V; ANSI/ESDA/JEDEC JS-001-2010.				
		Machine Model, class B: 200V to 400V; ANSI/ESDA/JEDEC JS-001-2010.				
	Moisture Sensitivity Level	Not humidity sensitive.				
	Vibration	Test Condition: 0.75mm ;acceleration:10g;10Hz~500Hz, one cycle per 30 min, test 2 hour. (3 times for each 3 directions X , Y , Z), IEC 68-2-06 Test Fc.				
Shock	50g; 11ms; half sine wave (3 times for each 3 directions X , Y , Z),IEC 68-2-27 Test Ea/Severity 50A.					



2. Mechanical Structure (mm)

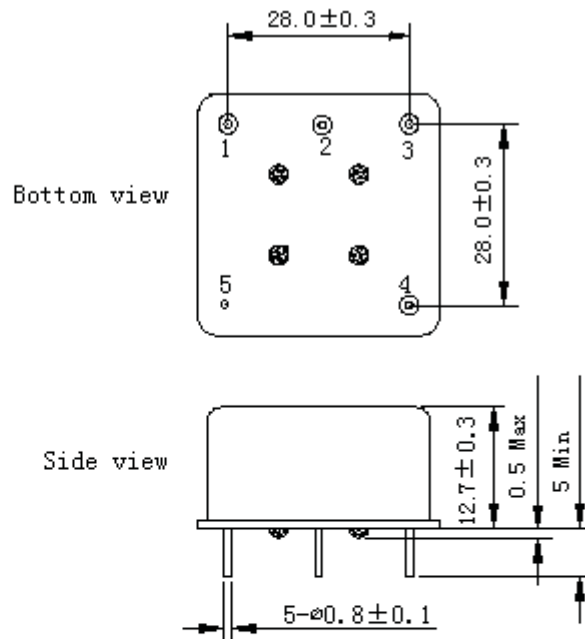

PIN FUNCTION

PIN	NOTATION	FUNCTION
1	VC	VC
2	VREF	Reference Voltage
3	VCC	Supply Voltage
4	RF	RF Output
5	GND	GND

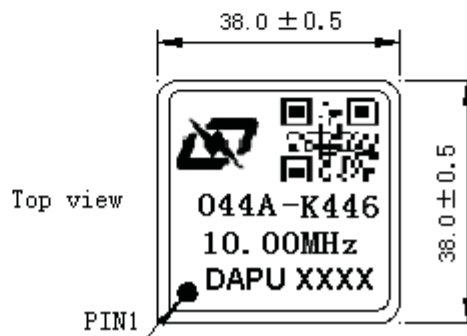

- Note1:** Tolerance ± 0.2 mm without mark
- Note2:** The first two xx representative: week
After two xx representative: year
- Note3:** Referential Weight 13.6g
- Note4:** NC is not connect



3. Test Circuit

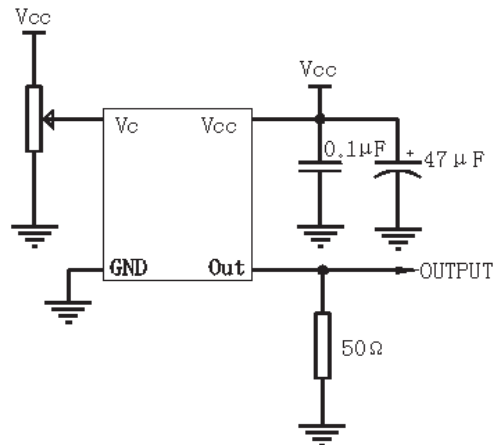

4. Reflow Soldering Curve (RoHS)

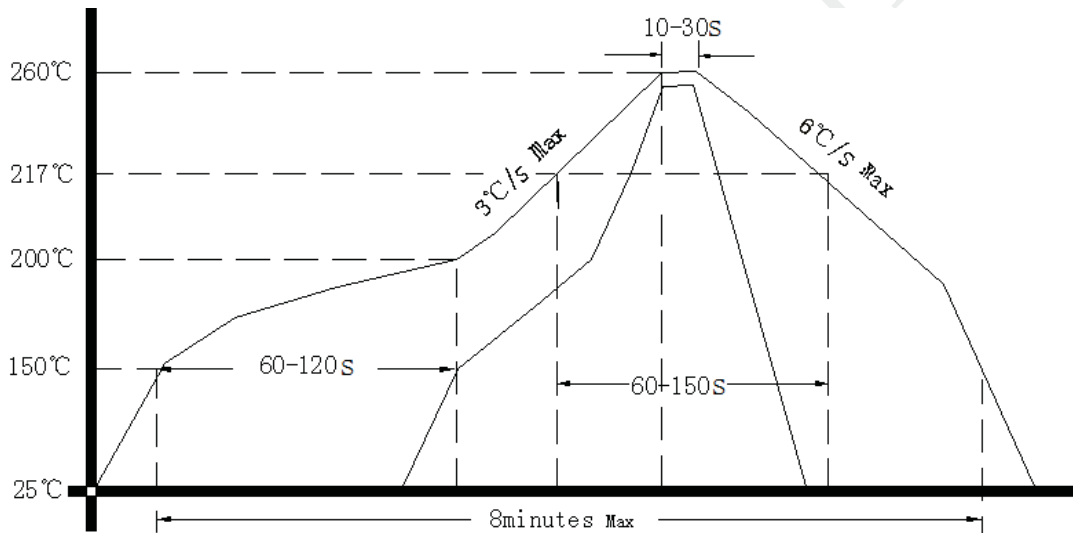

5. Package(mm)

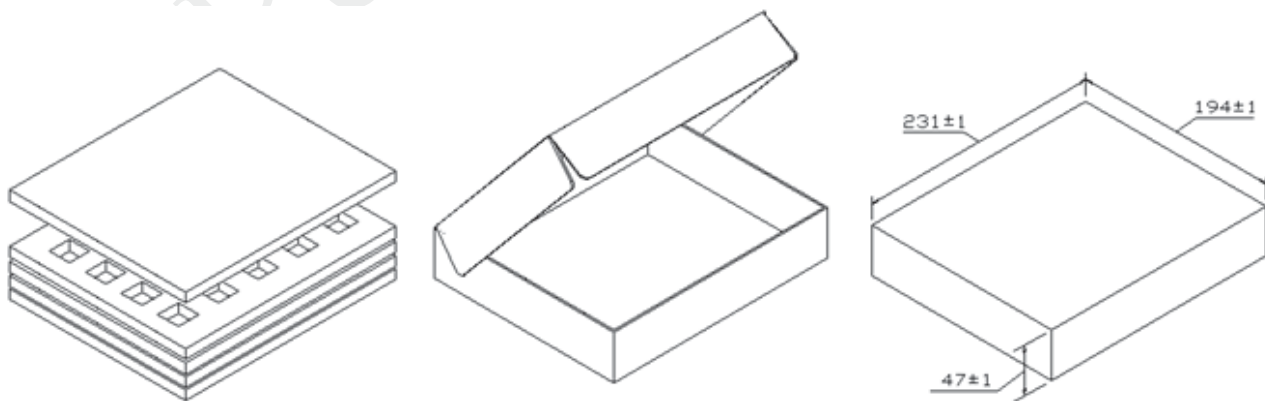

Buffer material

Cardboard
Max 20pcs. circulator