

Travelling Merchant: _____

DATASHEET

Standard: **T77A-K413-10.00MHz**

P/N: _____

Plot			The Label
Drew	Audited	Approved	Stamp, please! Thanks!
Date: 2019.07.04			

Guangdong Dapu Telecom Technology Co.,Ltd

Bldg13-16,.N.Ind.Zone,SSL Industry Park, Dongguan City, Guangdong Province, China

TEL: 0086-0769-88010888 FAX: 0086-0769-81800098



Table of amendment

Version	Revision contents	Prepared by	Revised date
1.0	The first issued	<i>Amway</i>	2019.07.04



1、Electrical Parameters

MODEL: T77A-K413-10.00MHz						
Item	Description	Parameters			Unit	Test Condition
		Min.	Typ.	Max.		
Output	Frequency	10.00			MHz	
	Output Waveform	Sine Wave				
	Level	5			dBm	
	Load	50			Ω	
Frequency Stabilities	Frequency Tolerance vs. Operating Temperature Range	-0.05		+0.05	$\times 10^{-6}$	T_A varied from -40°C to 85°C , measurement referenced to frequency observed with $f_{\text{ref}}=(f_{\text{max}}+f_{\text{min}})/2$, $V_{\text{cc}}=3.3\text{V}$, $V_c=1.65\text{V}$, $O_{\text{Load}}=50\Omega$. temperature variable speed less than 2°C per minute.
	Initial Frequency Tolerance	-0.5		+0.5	$\times 10^{-6}$	Measurement referenced to frequency observed with $T_A=25^{\circ}\text{C}$, $V_{\text{cc}}=3.3\text{V}$, $V_c=1.65\text{V}$ within 30 days after ex-works.
	Frequency Tolerance vs. Supply Voltage	-0.1		+0.1	$\times 10^{-6}$	measurement referenced to frequency observed $T_A=25^{\circ}\text{C}$, V_{cc} varied from 3.13V to 3.47V, $V_c=1.65\text{V}$ and $O_{\text{Load}}=50\Omega$.
	Frequency Tolerance vs. Load	-0.2		+0.2	$\times 10^{-6}$	10% load change measurement referenced to frequency observed with $T_A=25^{\circ}\text{C}$, $V_{\text{cc}}=3.3\text{V}$, $V_c=1.65\text{V}$ and $O_{\text{Load}}=50\Omega$.
	RMS Jitter (By E5052B)	0.4		1.3	ps	12KHz-5MHz
	Aging Tolerance 1 Year	-1		+1	$\times 10^{-6}$	$T_A=25^{\circ}\text{C}$, $V_{\text{cc}}=3.3\text{V}$, $V_c=1.65\text{V}$ and after 1h of operation.
Power Supply	Operating Current			10	mA	@ 25°C , $V_{\text{cc}}=3.3\text{V}$, $V_c=1.65\text{V}$, $O_{\text{Load}}=50\Omega$
	Supply Voltage	3.13	3.3	3.47	V	
Voltage Control	Frequency tuning range	-11		-5	$\times 10^{-6}$	$V_c=0\text{V}$. measurement referenced to $V_c=1.65\text{V}$.
		-0.5		+0.5	$\times 10^{-6}$	$V_c=1.65\text{V}$. measurement referenced to Exactly 10.00MHz.
		+5		+11	$\times 10^{-6}$	$V_c=3.3\text{V}$. measurement referenced to $V_c=1.65\text{V}$.
	Linearity			10	%	
	Slope	Positive				
	Input Impedance	100			$\text{K}\Omega$	



Phase Noise	Phase Noise		-90	-85	dBc/Hz	10Hz
			-120	-115		100Hz
			-145	-140		1KHz
			-153	-148		10KHz
			-155	-150		100KHz
			-155	-150		1MHz
Environmental Conditions	Operable Temperature	-40		+85	°C	
	Storage Temperature	-55		+125	°C	
	ESD Level	Human Body Model, class2: 2000V to 4000V; ANSI/ESDA/JEDEC JS-001-2010.				
		Machine Model, class B: 200V to 400V; ANSI/ESDA/JEDEC JS-001-2010.				
	Moisture Sensitivity Level	Level 3.				
	Vibration	Test Condition: 0.75mm ;acceleration:10g;10Hz~2000Hz, one cycle per 30 min, test 2 hour. (3 times for each 3 directions X , Y , Z) .IEC 68-2-06 Test Fc.				
Shock	100g; 6ms; half sine wave (3 times for each 3 directions X , Y, Z),IEC 68-2-27 Test Ea/Severity 50A.					



2、 Mechanical Structure(mm)

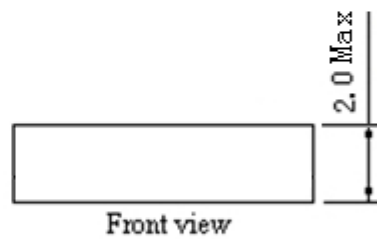
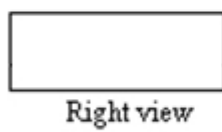
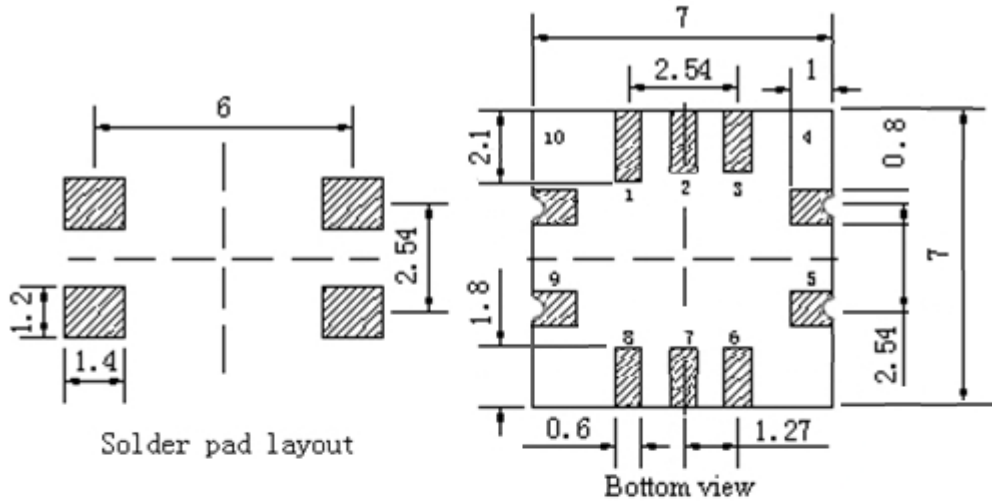

Pin Function	
Pin	Function
1, 2, 3, 6, 7, 8	NC
4	GND
5	OUTPUT
9	VCC
10	VC

Note1: Tolerance ± 0.2 mm without mark

Note2: Referential Weight 0.2g

Note3: NC is not connect



3、 Test Circuit

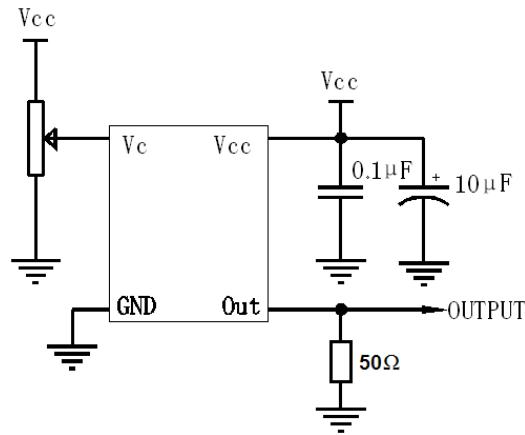

4、 Reflow Soldering Curve (RoHS)

