

Travelling Merchant: _____

DATASHEET

Standard: DP7V2400008

Plot			The Label
Drew	Audited	Approved	Stamp, please! Thanks!
Date: 2018.05.02			

Guangdong Dapu Telecom Technology Co.,Ltd

Bldg13,.N.Ind.Zone,SSL Industry Park, Dongguan City, Guangdong Province, China

TEL: 0086-0769-88010888 FAX: 0086-0769-81800098



1、Electrical Parameters

MODEL: DP7V12000008

No.	Parameters	SYM.	Electrical Spec.				Notes
			Min.	Typ.	Max.	Units	
1	Nominal Frequency	FL	24.00			MHz	
2	Oscillation Mode	-	Fundamental				
3	Load Capacitance	CL	15			pF	
4	Frequency Tolerance	-	-10		+10	ppm	at 25°C ±3°C
5	Frequency Stability	-	-30		+30	ppm	At -40°C ~+85°C
6	Operating Temperature Range	-	-40	~	+85	°C	
7	Aging	-	-3		+3	ppm	1st Year
8	Drive Level	DL	-		100	uW	
9	Equivalent Series Resistance	Rr	-	-	50	Ω	
10	Shunt Capacitance	C0	-	-	5.0	pF	
11	Insulation Resistance	-	500	-	-	MΩ	at DC 200V
12	Storage Temperature Range	-	-40	~	+85	°C	



2、Mechanical Structure(mm)

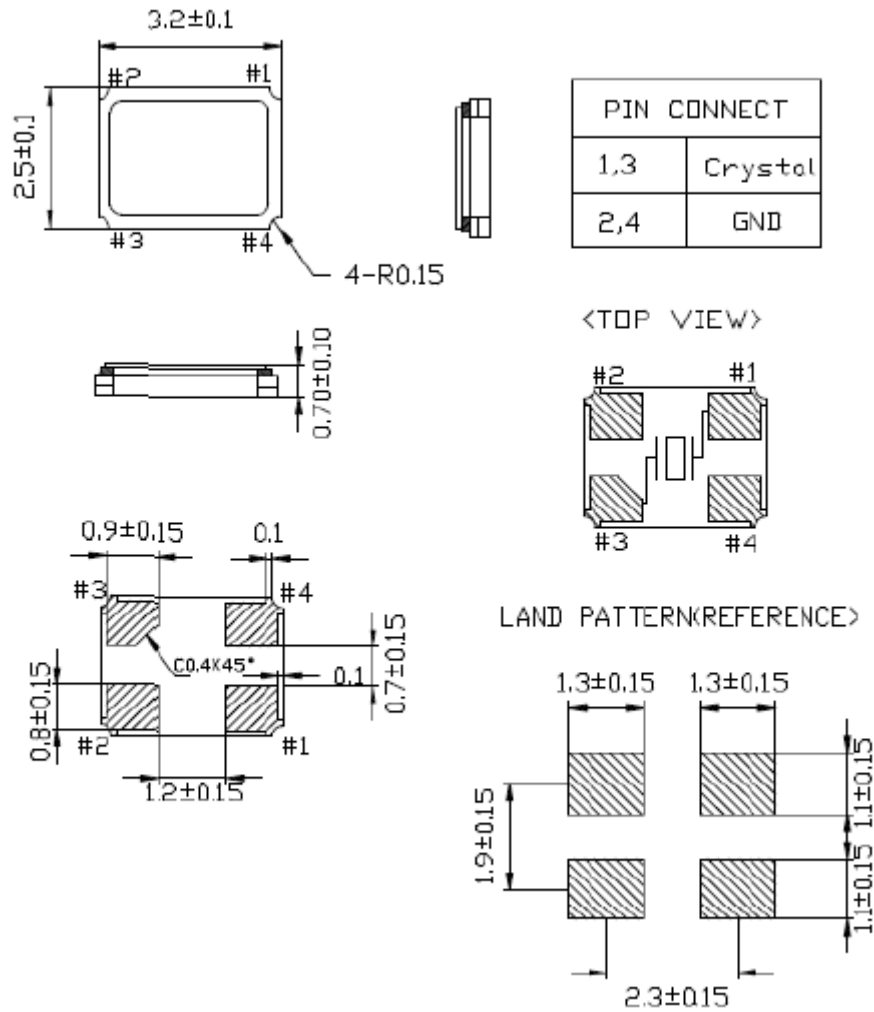



3、Reliability test

序号 NO.	试验项目 Test Item	试验条件 Condition of Test	标准要求 Performance Requirements
1	跌落 Drop	从75cm位置高度,自由跌落在木板上,连续3次 [Form 75cm height 3 times on 3cm hard wooden floor]	试验前后,频率变化不超过 $\pm 5\text{ppm}$,电阻变化不超过 $\pm 15\%$ (1).Frequency Change: $\pm 5\text{ppm}$ (2).Resistance: $\pm 15\%$
2	振动 Vibration	振动频率(Frequency) : 10~55 Hz 全振幅(Amplitude) : 1.5mm $\pm 15\%$ 时间(Period) : 每个方位三面(X、Y、Z)各振动2小时[3 direction (x, y, z) each for 2 hrs]	试验前后,频率变化不超过 $\pm 5\text{ppm}$,电阻变化不超过 $\pm 15\%$ (1).Frequency Change: $\pm 5\text{ppm}$ (2).Resistance: $\pm 15\%$
3	冷热冲击 Temperature Cycle	晶体放入试验箱中,高低温循环100次[The crystal is put into the test box, and the high and low temperature cycle is 100 times] 低温为 $-40\pm 3^\circ\text{C}$ 保持30分钟,高温 $85\pm 2^\circ\text{C}$ 保持保持30分钟,高、低温每3分钟变换一次[The low temperature is kept at $-40\pm 3^\circ\text{C}$ for 30 minutes, and the high temperature is maintained at $85\pm 2^\circ\text{C}$ for 30 minutes, and the high and low temperature are changed every 3 minutes.] 	试验前后,频率变化不超过 $\pm 5\text{ppm}$,电阻变化不超过 $\pm 15\%$ (1).Frequency Change: $\pm 5\text{ppm}$ (2).Resistance: $\pm 15\%$
4	气密性(大漏) Sealing (Gross Leak)	气密检测机(Sealing Check Equipment) 试验压力(Test Pressure):0.2 Mpa	漏率标准(leak rate) : $\leq 1 \times 10^{-4} \text{Pa} \cdot \text{m}^3/\text{s}$
5	气密性(细漏) Sealing (Fine leak)	氦气气压标准 : 5~5.5 kgf / cm^2 , 氦气加压时间 : 2 小时 [Helium bombing 5~5.5 kgf / cm^2 for 2 hours.]	漏率标准(leak rate) : $\leq 1 \times 10^{-9} \text{Pa} \cdot \text{m}^3/\text{s}$

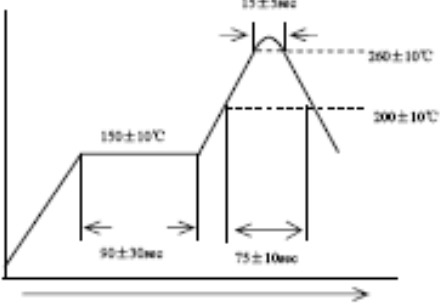

6	耐焊接热 Resistance to soldering heat	<p>波峰温度(Peak Temp) : $260^{\circ}\text{C} \pm 10^{\circ}\text{C}$ 时间(Time) : $15\text{s} \pm 5\text{sec}$</p> 	<p>试验前后,频率变化不超过$\pm 5\text{ppm}$,电阻变化不超过$\pm 15\%$ (1).Frequency Change:$\pm 5\text{ppm}$ (2).Resistance:$\pm 15\%$</p>
7	沾锡试验 Solder bility	<p>温度(Temperature) : $260^{\circ}\text{C} \pm 10^{\circ}\text{C}$ 浸泡时间(Soaking Time) : $3\text{s} \pm 1\text{sec}$</p>	<p>引脚沾锡后覆盖面积达 90%以上[A new uniform coating of solder shall cover min mun 95% of the surface being immersed.]</p>
8	高温高湿 High Temp. & Humidity	<p>温度(Temperature) : $60^{\circ}\text{C} \pm 2^{\circ}\text{C}$ 湿度(Humidity) : 90%~95% 保持时间(Hold time): 500 hours</p>	<p>1. 试验前后,频率变化不超过$\pm 5\text{ppm}$,电阻变化不超过$\pm 15\%$ (1).Frequency Change:$\pm 5\text{ppm}$ (2).Resistance:$\pm 15\%$ 2. 制品表面不可生锈[No rust on the surface of the product.]</p>
9	高温试验 High Temperature Storage	<p>高温温度(Temperature) : $85^{\circ}\text{C} \pm 2^{\circ}\text{C}$ 时间(Hold time): 500 hours</p>	<p>试验前后,频率变化不超过$\pm 5\text{ppm}$,电阻变化不超过$\pm 15\%$ (1).Frequency Change:$\pm 5\text{ppm}$ (2).Resistance:$\pm 15\%$</p>
10	低温试验 Low Temperature Storage	<p>低温温度(Temperature) : $-40^{\circ}\text{C} \pm 2^{\circ}\text{C}$ 时间(Hold time): 500 hours</p>	<p>试验前后,频率变化不超过$\pm 5\text{ppm}$,电阻变化不超过$\pm 15\%$ (1).Frequency Change:$\pm 5\text{ppm}$ (2).Resistance:$\pm 15\%$</p>
11	盐雾 Salt Mist	<p>盐雾浓度 (Salt mist concentration) : 5% 温度(Temperature) : 25°C 时间(Hold time):36 hours</p>	<p>制品表面不可生锈[No rust on the surface of the product.]</p>

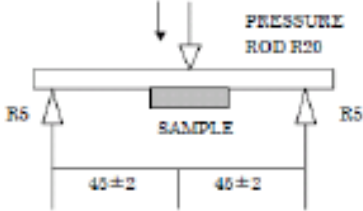
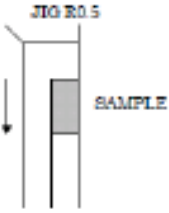
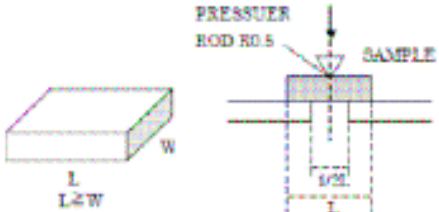

12	折板弯曲试验 Terminal Strength	高度(Height) : 3mm 时间(Time) : 5sec 速度(Speed) : 0.5mm/sec 	试验前后,频率变化不超过±5ppm,电阻变化不超过±15% 1).Frequency Change:±5ppm (2).Resistance:±15%
13	折板推力试验 Sticking Tendency	荷重(Load) : 10N 时间(Hold time) : 10sec 治具(Tool) : R0.5(制品侧边位置[Side position of product]) 	试验前后,频率变化不超过±5ppm,电阻变化不超过±15% 1).Frequency Change:±5ppm (2).Resistance:±15%
14	本体荷重试验 Element Assembly Strength	荷重(Load) : 10N 时间(Hold time) : 10 sec 治具(Tool) : R0.5(制品中心位置[Center position of product]) 	试验前后,频率变化不超过±5ppm,电阻变化不超过±15% 1).Frequency Change:±5ppm (2).Resistance:±15%



3、 Packing Descripction

6.1 帶子尺寸[CARRIER TYPE] (unit:mm)

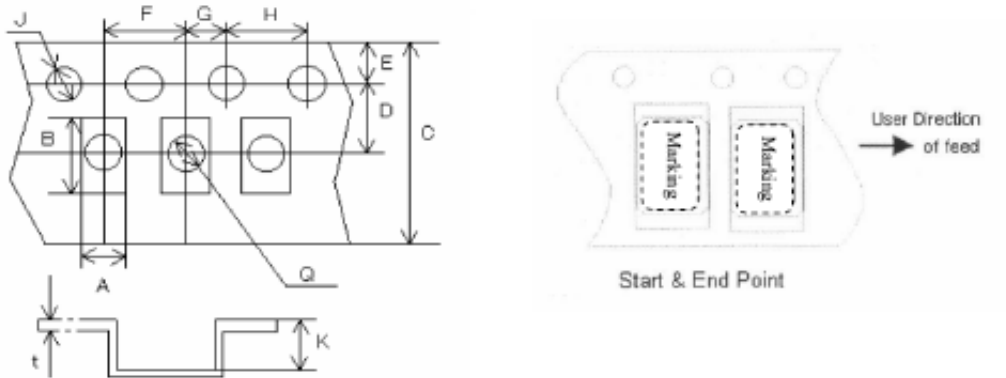

A	B	C	D	E	F	G	H	J	K	t
2.7	3.4	8.0	3.5	1.75	4.0	2.0	4.0	1.55	1.4	0.25

6.2 卷盘尺寸[REEL] (unit:mm)

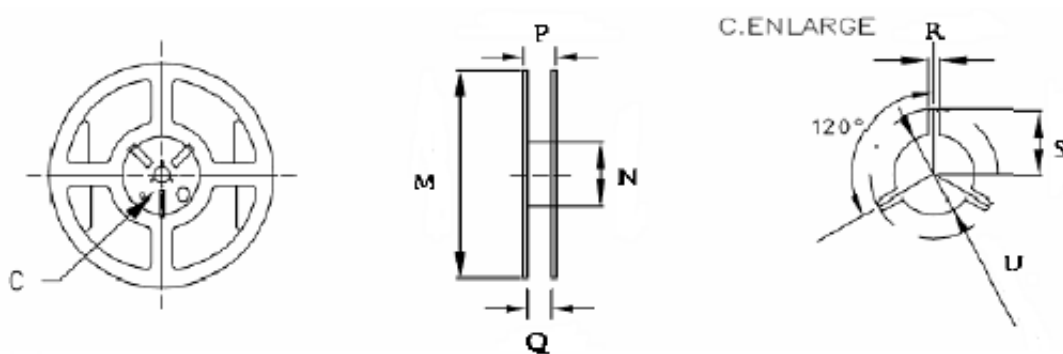

M	N	P	Q	R	S	U
178.0	60.2	11.5	8.0	2.5	11.0	13.0