



1. Electrical Parameters

MODEL: O23B-0802-12.80MHz							
Item	Description	Parameters			Unit	Test Condition	
		Min.	Typ.	Max.			
Output	Frequency	12.80			MHz		
	Output Waveform	HCMOS					
	Output Low Voltage			0.5	V	$V_{cc}=5.0V, O_{load}=15pF$	
	Output High Voltage	4.5			V	$V_{cc}=5.0V, O_{load}=15pF$	
	Duty Cycle	45	50	55	%	@50%	
	Rise / Fall Time (10%~90%)			3	ns		
	Load	15 ± 10%			pF		
Frequency Stabilities	Frequency Tolerance vs. Operating Temperature Range	-10		+10	$\times 10^{-9}$	T_A varied from -10°C to 60°C, measurement referenced to frequency observed with $f_{ref}=(f_{max}+f_{min})/2, V_{cc}=5.0V, V_c=2.0V, O_{load}=15pF$, temperature variable speed less than 2°C per minute.	
	Initial Frequency Tolerance	-0.1		+0.1	$\times 10^{-6}$	Measurement referenced to frequency observed with $T_A=25^\circ C, V_{cc}=5.0V, V_c=2.0V$, and after 30 minutes of operation, within 30 days after ex-works.	
	Frequency Tolerance vs. Supply Voltage	-2.0		+2.0	$\times 10^{-9}$	measurement referenced to frequency observed $T_A=25^\circ C, V_{cc}$ varied from 4.75V to 5.25V, $V_c=2.0V$, and $O_{Load}=15pF$.	
	Frequency Tolerance vs. Load	-1.0		+1.0	$\times 10^{-9}$	5% load change measurement referenced to frequency observed with $T_A=25^\circ C, V_{cc}=5.0V, V_c=2.0V$, and $O_{Load}=15pF$.	
	Short-Term Stability Allan Variance				0.05	$\times 10^{-9}$	Temperature stability, no EMI\EMC or other interference, test after power for 1hour ref. to 25°C; 1s, using PN9000 equipment.
					0.1	$\times 10^{-9}$	Temperature stability, no EMI\EMC or other interference, test after power for 1hour ref. to 25°C; 100s, using PN9000 equipment.
	Aging Tolerance Per Day	-0.5		+0.5	$\times 10^{-9}$	V_{cc}, V_c, T_A constant measurement referenced to frequency observed with $T_A=25^\circ C, V_{cc}=5.0V, V_c=2.0V$, and after 30 days of operation.	
	Aging Tolerance 1 Year	-0.05		+0.05	$\times 10^{-6}$		
	Aging Tolerance 10 Year	-0.6		+0.6	$\times 10^{-6}$		



Power Supply	Supply Voltage	4.75	5.0	5.25	V	
	Steady Consumption			250	mA	@25°C
	Warm up current			600	mA	
	Warm up time			15	min	@25 °C within $\pm 0.01 \times 10^{-6}$ of final frequency with reference after 1 hour on.
Voltage Control Characteristics	Frequency Tuning Range	-1.3		-0.5	$\times 10^{-6}$	$V_c=0V$. measurement referenced to $V_c=2.0V$.
		-0.1		+0.1	$\times 10^{-6}$	$V_c=2.0V$. measurement referenced to exactly 12.80MHz.
		+0.5		+1.3	$\times 10^{-6}$	$V_c=4.0V$. measurement referenced to $V_c=2.0V$.
	Linearity			10	%	
	Slope	Positive				
	Modulation Bandwidth	10			KHz	
	Input Impedance	100			K Ω	
Jitter			1	ps	RMS(12K~20M)	
Phase Noise	Phase Noise		-120	-110	dBc/Hz	10Hz
			-135	-125		100Hz
			-150	-145		1KHz
			-150	-145		10KHz
			-150	-145		100KHz
Environmental Conditions	Operating Temperature	-10		+70	°C	
	Operable Temperature	-40		+70	°C	
	Storage Temperature	-55		+85	°C	
	ESD Level	Human Body Model, class2: 2000V to 4000V; ANSI/ESDA/JEDEC JS-001-2010.				
		Machine Model, class B: 200V to 400V; ANSI/ESDA/JEDEC JS-001-2010.				
	Moisture Sensitivity Level	Not humidity sensitive.				
	Vibration	Test Condition: 0.75mm ;acceleration:10g;10Hz~500Hz, one cycle per 30 min, test 2 hour. (3 times for each 3 directions X , Y , Z), IEC 68-2-06 Test Fc.				
Shock	50g; 11ms; half sine wave (3 times for each 3 directions X, Y, Z), IEC 68-2-27 Test Ea/Severity 50A.					
Full Package Storage	Relative humidity (%)	20%~70%				
	Temperature (°C)	-10~35°C				



2. Mechanical Structure (mm)

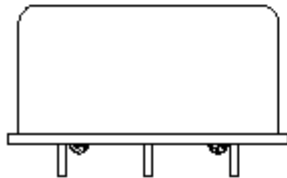
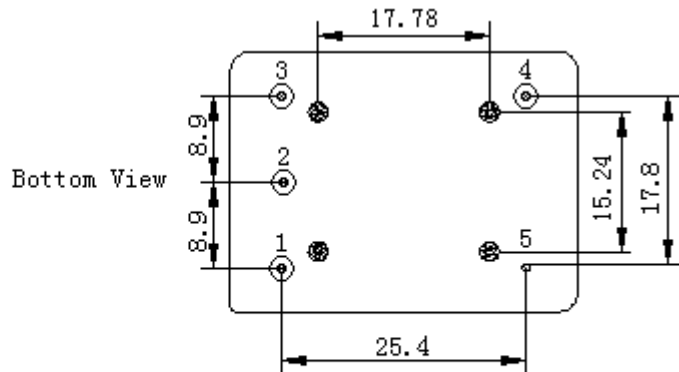

Right View

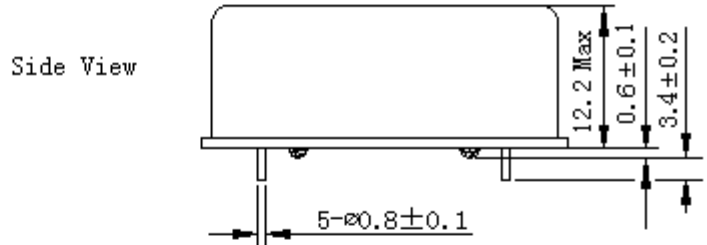

Side View

PIN FUNCTION

PIN	NOTATION	FUNCTION
1	VC	Control Voltage
2	NC	Not Connect
3	VCC	Supply Voltage
4	OUTPUT	RF Output
5	GND	GND

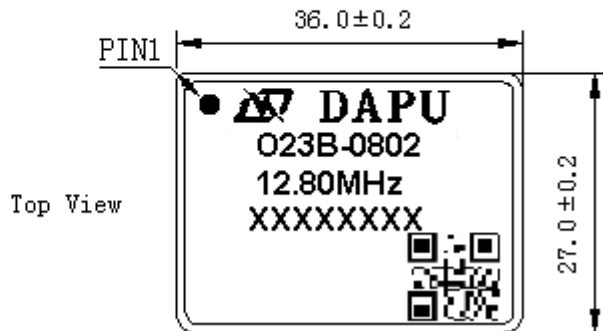

Top View

Note1: Tolerance ± 0.2 mm without mark

Note2: The first two xx representative: week

After two xx representative: year

At last four xxxx representative: serial number

Note3: Referential weight 20.7g

Note4: NC is not connect



3. Test Circuit

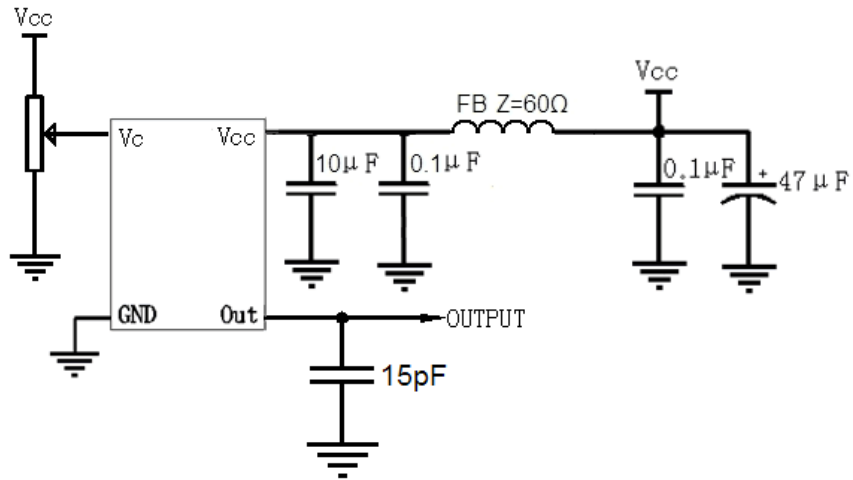

4. Reflow Soldering Curve (RoHS)

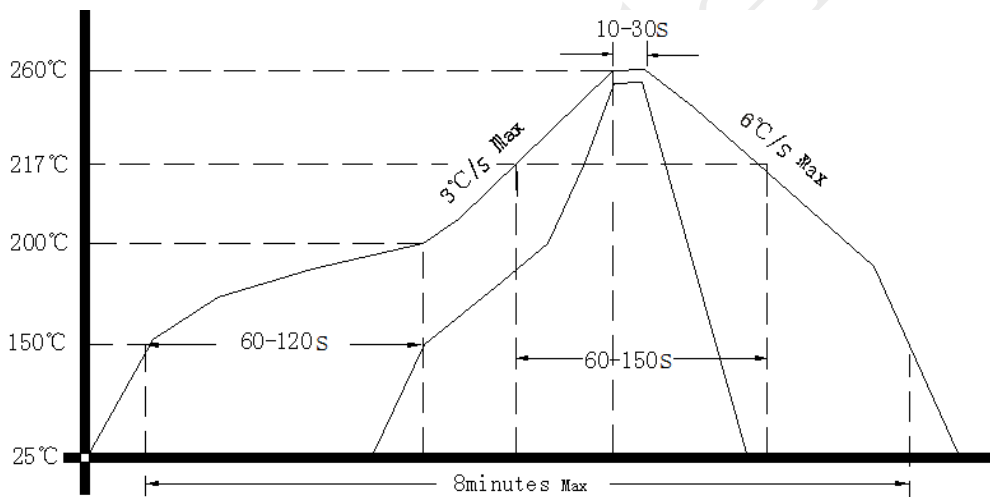

5. Package (mm)

