





**Table of amendment**

Version	Revision contents	Prepared by	Revised date
1.0	The first issued	<i>Amway</i>	2018.08.03



## 1. Electrical Parameters

MODEL: O22B-0804-10.00MHz						
Item	Description	Parameters			Unit	Test Condition
		Min.	Typ.	Max.		
Output	Frequency	10.00			MHz	
	Output Waveform	LVTTTL				
	Output Low Voltage			0.4	V	$V_{cc}=3.3V, O_{load}=15pF$
	Output High Voltage	2.8		3.1	V	$V_{cc}=3.3V, O_{load}=15pF$
	Duty Cycle	45	50	55	%	@50%
	Rise / Fall Time (10%~90%)			6	ns	
	Load	15 ±10%			pF	
	Spurious			-60	dBc	
	Output overshoot			10	%	
Frequency Stabilities	Frequency Tolerance vs. Operating Temperature Range	-0.01		+0.01	$\times 10^{-6}$	$T_A$ varied from $-10^{\circ}C$ to $70^{\circ}C$ , measurement referenced to frequency observed with $f_{ref}=(f_{max}+f_{min})/2, V_{cc}=3.3V, V_c=1.65V, O_{load}=15 pF,$ temperature rise speed less than $2^{\circ}C$ per minute.
		-0.01		+0.01	$\times 10^{-6}$	$T_A$ varied from $-10^{\circ}C$ to $-40^{\circ}C$ , measurement referenced to frequency observed with $f_{ref}=f_{max}+f_{min}, V_{cc}=3.3V, V_c=1.65V, O_{load}=15 pF,$ temperature rise speed less than $2^{\circ}C$ per minute.
	Initial Frequency Tolerance	-0.2		+0.2	$\times 10^{-6}$	Measurement referenced to frequency observed with $T_A=25^{\circ}C, V_{cc}=3.3V, V_c=1.65V,$ and after 30 minutes of operation, within 180days after ex-works .
	Frequency Tolerance vs. Supply Voltage	-2		+2	$\times 10^{-9}$	measurement referenced to frequency observed $T_A=25^{\circ}C, V_{cc}$ varied from 3.13V to 3.47V, $V_c=1.65V$ and $O_{Load}=15pF.$
	Frequency Tolerance vs. Load	-2		+2	$\times 10^{-9}$	10% load change measurement referenced to frequency observed with $T_A=25^{\circ}C, V_{cc}=3.3V, V_c=1.65V,$ and $O_{Load}=15pF.$
	Short-Term Stability: Alan Variance			0.05	$\times 10^{-9}$	Temperature stability, no EMI\EMC or other interference, test after power for 48 hour ref. to $25^{\circ}C$ ; 1s, using PN9000 equipment.
	Daily Fluctuation	-5		+5	$\times 10^{-9}$	$25\pm 5^{\circ}C$



	Retrace	-0.01		+0.01	$\times 10^{-6}$	24 hour continuous power on ,power off 24 hour, power on 1 hour.
	Aging Tolerance Per Day	-1.0		+1.0	$\times 10^{-9}$	
	Aging Tolerance 1 Year	-0.1		+0.1	$\times 10^{-6}$	
	Aging Tolerance 10Year	-0.4		+0.4	$\times 10^{-6}$	
Power Supply	Supply Voltage	3.13	3.3	3.47	V	Tolerate input voltage (no damage) -0.3VDC~4.0VDC
	Steady Consumption			400	mA	@25°C
	Warm up current			1000	mA	
	Warm-Up Time			15	minutes	@25 °C within $\pm 0.01 \times 10^{-6}$ power on 5 minutes compared with 1 hour
Voltage Control Characteristics	Frequency Tuning Range	-2.4		-0.8	$\times 10^{-6}$	$V_c=0V$ . measurement referenced to $V_c=1.65V$
		-0.2		+0.2	$\times 10^{-6}$	$V_c=1.65V$ . measurement referenced to exactly 10.00MHz
		+0.8		+2.4	$\times 10^{-6}$	$V_c=3.3V$ . measurement referenced to $V_c=1.65V$
	Linearity			10	%	
	Slope		Positive			
	Input Impedance	100			K $\Omega$	
Jitter				1	ps	RMS (12kHz ~10MHz), power ripple < 50mV
Phase Noise	Phase Noise		-80	-70	dBc/Hz	1Hz
			-120	-110		10Hz
			-140	-130		100Hz
			-145	-140		1KHz
			-150	-145		10KHz
			-155	-150		100KHz



Environmental Conditions	Operating Temperature	-10		70		
	Operable Temperature	-40		+85	°C	
	Storage Temperature	-40		+85	°C	
	ESD Level	Human Body Model, class2: 2000V to 4000V; ANSI/ESDA/JEDEC JS-001-2010.				
		Machine Model, class B: 200V to 400V; ANSI/ESDA/JEDEC JS-001-2010.				
	Moisture Sensitivity Level	Not humidity sensitive.				
	Vibration	Test Condition: 0.75mm ;acceleration:10g;10Hz~500Hz, one cycle per 30 min, test 2 hour. (3 times for each 3 directions X , Y , Z), IEC 68-2-06 Test Fc.				
Shock	50g; 11ms; half sine wave (3 times for each 3 directions X, Y, Z), IEC 68-2-27 Test Ea/Severity 50A.					
Full Package Storage	Relative humidity (%)	20% ~70%				
	Temperature (°C)	-10~35°C				



## 2. Mechanical Structure (mm)

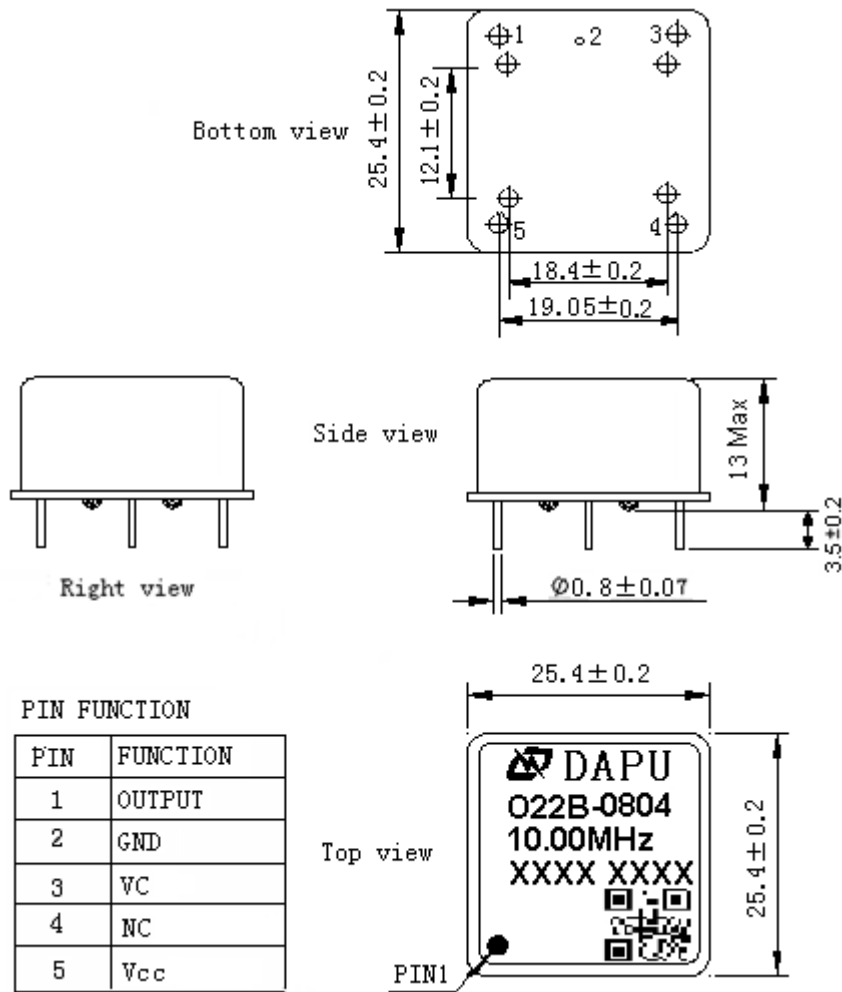

- Note1:** Tolerance ± 0.2mm without mark
- Note2:** Referential weight 13.6g
- Note3:** NC is not connect
- Note4:** The first two xx representative: week  
After two xx representative: year  
At last four xxxx representative: serial number



### 3. Test Circuit

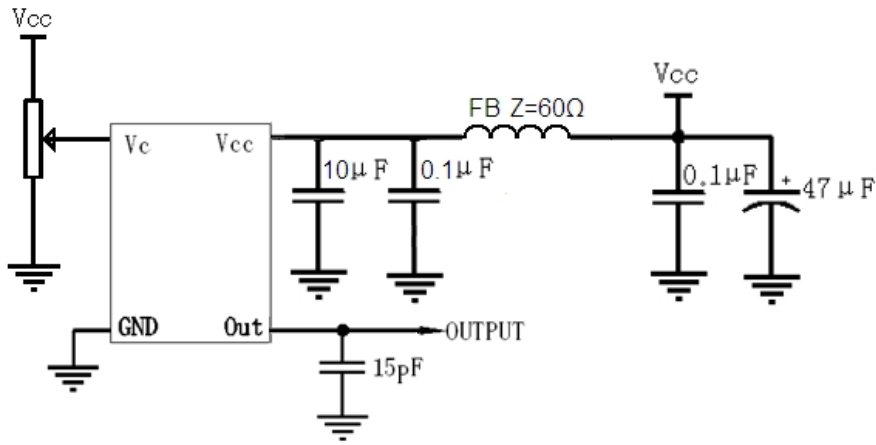

### 4. Reflow Soldering Curve (RoHS)

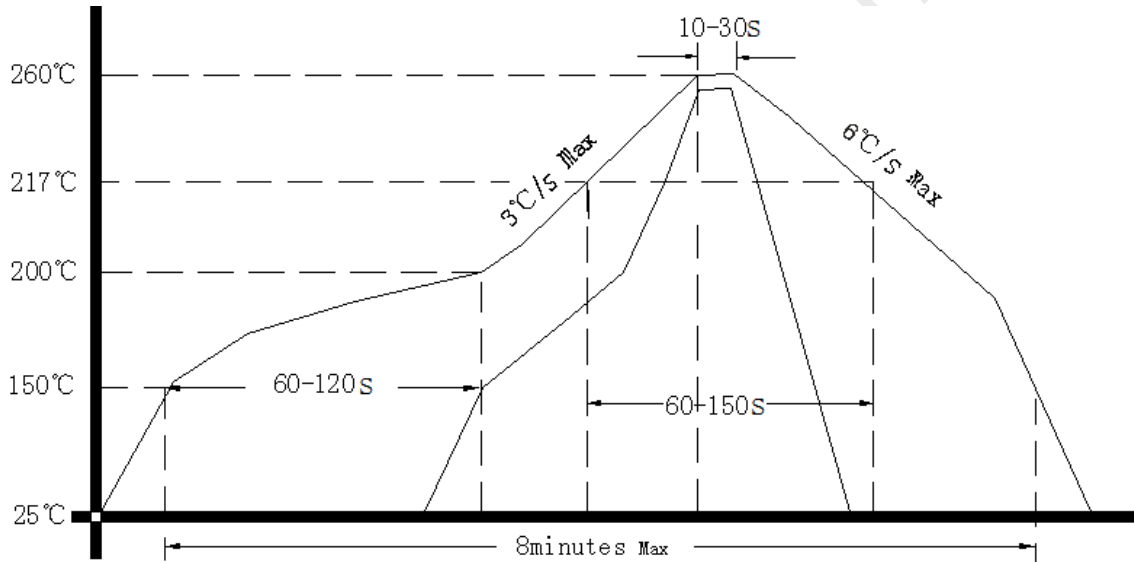

### 5. Package (mm)

