

Travelling Merchant: _____

DATASHEET

Standard: **T11B-A327-131.04MHz**

P/N: _____

Plot			The Label
Drew	Audited	Approved	Stamp, please! Thanks!
Date: 2018.08.28			

Guangdong Dapu Telecom Technology Co.,Ltd

Bldg13-16,.N.Ind.Zone,SSL Industry Park, Dongguan City, Guangdong Province, China

TEL: 0086-0769-88010888 FAX: 0086-0769-81800098



1. Electrical Parameters

MODEL: T11B-A327-131.04MHz						
Item	Description	Parameters			Unit	Test Condition
		Min.	Typ.	Max.		
Output	Frequency	131.04			MHz	
	Output Waveform	HCMOS				
	Output Low Voltage			0.33	V	$V_{cc}=5.0V, O_{load}=15\text{ pF}$
	Output High Voltage	2.97			V	$V_{cc}=5.0V, O_{load}=15\text{ pF}$
	Duty Cycle	45	50	55	%	@50%
	Rise / Fall Time (10%~90%)			2	ns	@25°C
	Load	15			pF	
	Start-up time			10	ms	
Frequency Stabilities	Frequency Tolerance vs. Operating Temperature Range	-30		+30	$\times 10^{-6}$	T_A varied from -40°C to 85°C, measurement referenced to frequency observed with $T_A = 25^\circ\text{C}, V_{cc} = 5.0V, V_c = 1.65V, O_{load} = 15\text{ pF}$, temperature variable speed less than 2°C per minute.
	Initial Frequency Tolerance	-15		+15	$\times 10^{-6}$	Measurement referenced to frequency observed with $T_A = 25^\circ\text{C}, V_{cc} = 5.0V, V_c = 1.65V$ within 30 days after ex-works.
	Frequency Tolerance vs. Supply Voltage	-5		+5	$\times 10^{-6}$	measurement referenced to frequency observed $T_A = 25^\circ\text{C}, V_{cc}$ varied from 4.75V to 5.25V, $V_c = 1.65V$ and $O_{Load} = 15\text{ pF}$.
	Frequency Tolerance vs. Load	-3		+3	$\times 10^{-6}$	5% load change measurement referenced to frequency observed with $T_A = 25^\circ\text{C}, V_{cc} = 5.0V, V_c = 1.65V, O_{Load} = 15\text{ pF}$.
	Aging Tolerance 1 Year	-5		+5	$\times 10^{-6}$	$T_A = 25^\circ\text{C}, V_{cc} = 5.0V, V_c = 1.65V$ and after 1h of operation.
Power Supply	Current Consumption			35	mA	@25°C, $V_{cc} = 5.0V, V_c = 1.65V, O_{load} = 15\text{ pF}$.
	Supply Voltage	4.75	5.0	5.25	V	



Voltage Control Characteristics	Frequency Tuning Range			-80	$\times 10^{-6}$	$V_c=0V$. measurement referenced to $V_c=1.65V$
		-15		+15	$\times 10^{-6}$	$V_c=1.65V$. measurement referenced to exactly 131.04MHz
		+80			$\times 10^{-6}$	$V_c=3.3V$. measurement referenced to $V_c=1.65V$
	Linearity			10	%	
	Slope	Positive				
	Input Impedance	1				MΩ
Phase Noise	Phase Noise			-150	dBc/Hz	100KHz
Environmental Conditions	Operable Temperature	-40		+85	°C	
	Storage Temperature	-55		+105	°C	
	ESD Level	Human Body Model, class2: 2000V to 4000V; ANSI/ESDA/JEDEC JS-001-2010.				
		Machine Model, class B: 200V to 400V; ANSI/ESDA/JEDEC JS-001-2010.				
	Moisture Sensitivity Level	Not humidity sensitive.				
	Vibration	Test Condition: 0.75mm; acceleration:10g;10Hz~2000Hz, one cycle per 30 min, test 2 hour. (3 times for each 3 directions X , Y , Z).IEC 68-2-06 Test Fc.				
Shock	100g; 6ms; half sine wave (3 times for each 3 directions X , Y , Z),IEC 68-2-27 Test Ea/Severity 50A.					
Full Package Storage	Relative humidity(%)	20%~70%				
	Temperature(°C)	-10~35°C				



2. Mechanical Structure(mm)

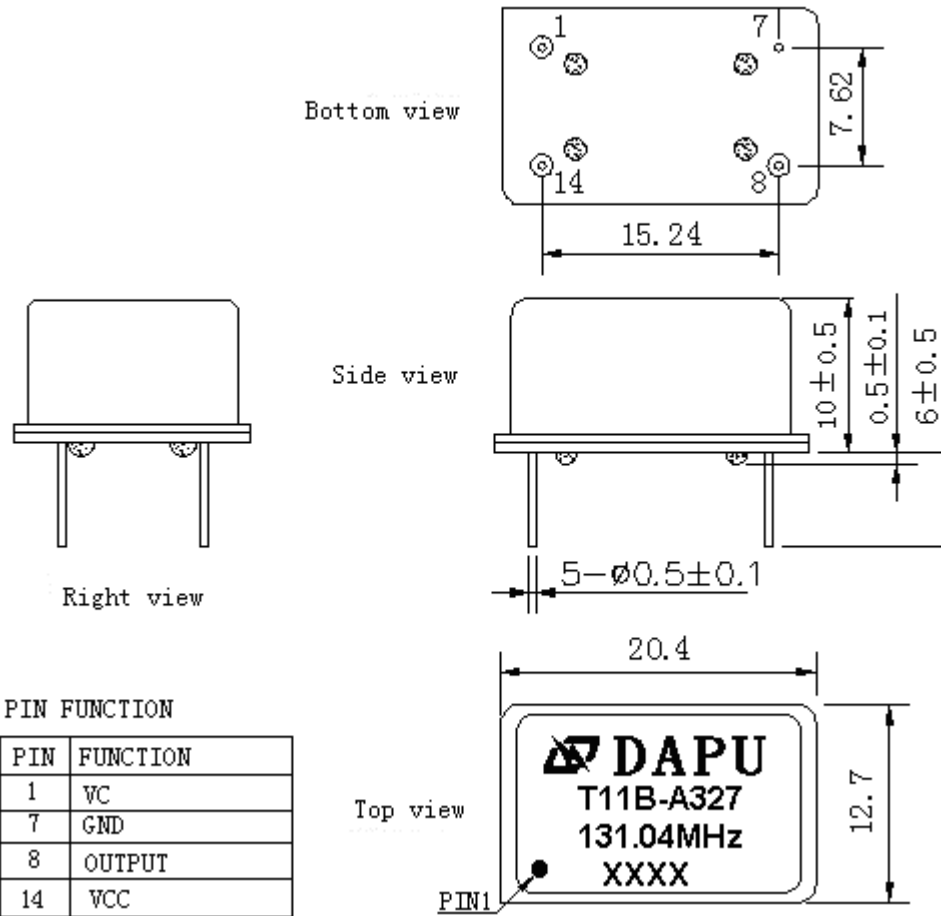

- Note1:** Tolerance $\pm 0.2\text{mm}$ without mark
- Note2:** Referential weight 4.2g
- Note3:** NC is not connect
- Note4:** The first two xx representative: week
After two xx representative: year



3. Test circuit

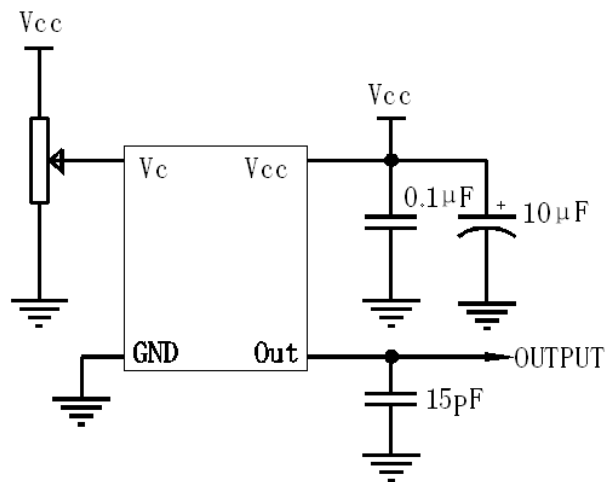

4. Reflow Soldering Curve (RoHS)

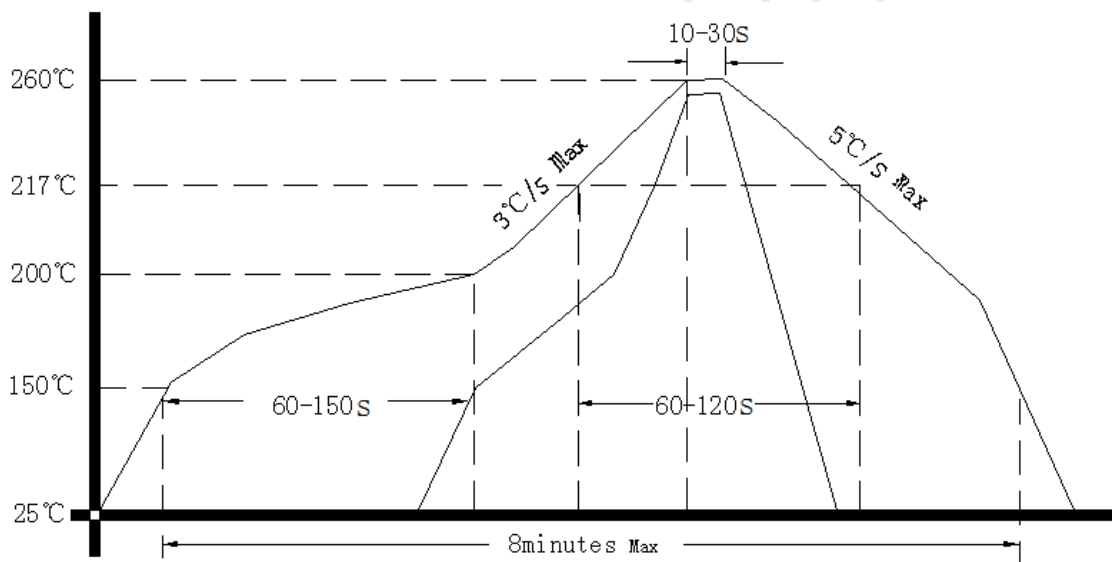

5. Package: Tape & Reel (mm)

