

Travelling Merchant: _____

DATASHEET

Standard: DP7W33333002

Plot			The Label
Drew	Audited	Approved	Stamp, please! Thanks!
Date: 2018.05.21			

Guangdong Dapu Telecom Technology Co.,Ltd

Bldg13,.N.Ind.Zone,SSL Industry Park, Dongguan City, Guangdong Province, China

TEL: 0086-0769-88010888 FAX: 0086-0769-81800098



1、Electrical Parameters

MODEL: DP7W33333002							
No.	Parameters	SYM.	Electrical Spec.				Notes
			Min.	Typ.	Max.	Units	
1	Nominal Frequency	FL	33.333			MHz	
2	Frequency Stability	-	-50		+50	ppm	incl. 25 °C tolerance, tolerance over operating temperature range, input voltage change, load change, 1 year aging
3	Operating Temperature	Topr	-40		+105	°C	
4	Storage Temperature	Tstg	-55	~	+125	°C	
5	Supply Voltage	VDD	3.3±10%			V	
6	Input Current	Icc	-	-	20	mA	
7	Output State Control	-	Enable/disable				
8	Output Load: CMOS	CL	15			pF	
9	Output Voltage High	VoH	90%Vdd	-	-	V	
10	Output Voltage Low	Vol	-	-	10%Vdd	V	
11	Rise Time	Tr	-	-	5	ns	10%-90% VDD Level
12	Fall Time	Tf	-	-	5	ns	90%-10% VDD Level
13	Symmetry (Duty ratio)	TH/T	45	50	55	%	
14	Start-up Time	Tosc	-	-	3	ms	
15	Standby current			-	10	μA	
16	Phase Jitter (rms)		-	-	1	ps	12kHz to 20MHz max
17	Aging	-	±3			ppm/yr.	1st. Year at 25°C
18	Oscillation mode		Fundamental				



2、Mechanical Structure(mm)

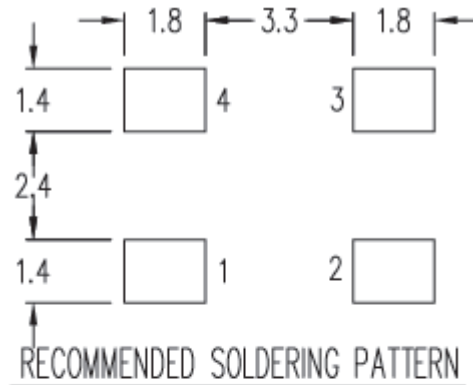
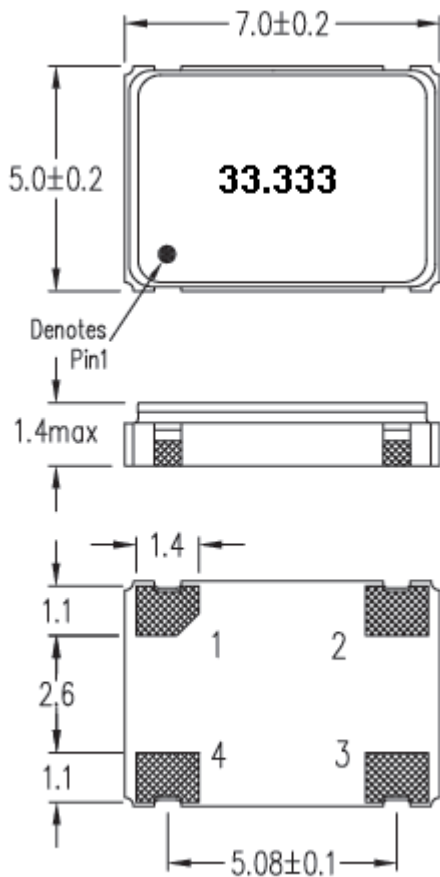

PIN CONNECTION

1	Enable/Disable*
2	GND
3	Output
4	VDD

* Enable/Disable functional description
When pin1 goes high ($\geq 0.7VDD$) or open, the Oscillator in normal operation and has output in frequency. When pin1 goes low ($\leq 0.3VDD$), the oscillator stops and the oscillator output (Pin3) becomes high impedance.

3、Test Circuit and Waveform

CMOS TEST CIRCUIT

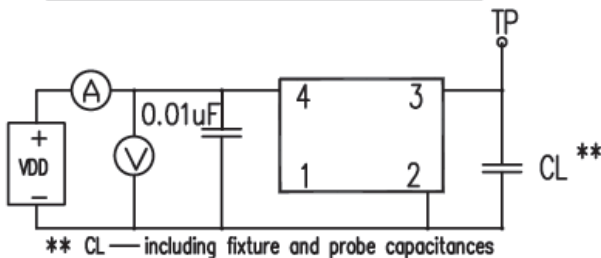

TYPICAL CMOS WAVE FORM

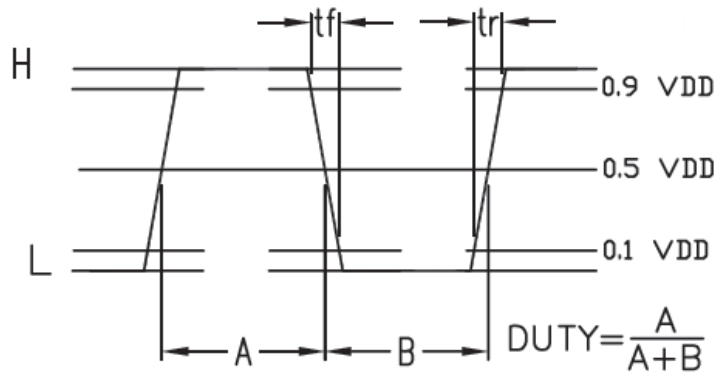



4、 Reliability Specifications

NO.	ITEM	SPECIFICATION	TEST METHOD
4.1	Temperature Cycle (GB/T 2423.22-2002, Method Nb)	Frequency change after test $\leq\pm$ 5ppm.	10 cycles from -55°C to 125°C. Measurement taken after DUT being left at room temperature for 24 \pm 2 hours.
4.2	Low Temperature Storage (GB/T 2423.1-2001, Method Aa)	Frequency change after test $\leq\pm$ 5ppm.	Spending 72 hrs at -55°C \pm 3°C constant temperature. Measurement taken after DUT being left at room temperature for 24 \pm 2 hours.
4.3	High Temperature Storage (GB/T 2423.2-2001, Method Ba)	Frequency change after test $\leq\pm$ 5ppm.	Spending 72 hrs at 125°C \pm 3°C constant temperature. Measurement taken after DUT being left at room temperature for 24 \pm 2 hours.
4.4	Humidity (GB/T 2423.3-2006, Method Cab)	Frequency change after test $\leq\pm$ 5ppm.	Spending 96 hrs at 40 °C \pm 3 °C, with 90 \pm 3% R.H. Measurement taken after DUT being left at room temperature for 24 \pm 2 hours.
4.5	Vibration (GB/T 2423.10-1995, Method Fc)	Frequency change after test $\leq\pm$ 5ppm.	Apply 0.75mm vibration at sweep frequency 10~500 Hz, for 2h. 10 cycles in each direction of 3 axis. Measurement taken after 1 hour.
4.6	Shock (GB/T 2423.5-1995, Method Ea)	Frequency change after test $\leq\pm$ 5ppm. No visible damages.	Peak 1000m/s ² , normal width 6ms half sine wave form, 3.7m/s, 3 perpendicular axis of samples, 3 cycles / direction, total 18 cycles. Measurement taken after 1 hour.
4.7	Drop (GB/T 2423.8-1995, Method Ed)	Frequency change after test $\leq\pm$ 5ppm. No visible damages.	Free drop to the wooden plate from 1.0 m heights for 3 times.
4.8	Solderability (GB/T 2423.28-2005, Method Tc)	Terminals shall be covered more then 95% with solder.	In 245 \pm 5°C solder bath for 2 \pm 0.5 seconds. There is no need to do functioned test. 8-12X magnifier.
4.9	Terminal Strength (JIS-C-6429 Method 1 & 2)	No visible damage	Mount on a glass-epoxy board (100x50x1.6mm), then bend to 2mm displacement (velocity 1mm/sec) and keep for 5 seconds. or pulling force 0.5 kg for at least 60 seconds.
4.10	Resistance to Soldering Heat (GB/T 2423.28-2005, Test Tb Method 1B)	Frequency change after test $\leq\pm$ 5ppm.	Passed through the re-flow oven under the following condition. Preheat to 150°C \pm 5°C for 60 to 120sec, and peak 265°C \pm 5°C for 10s \pm 3sec. Measurement taken after DUT being left at room temperature for at 24 \pm 2 hours.



5、 Package: Tape & Reel (mm)

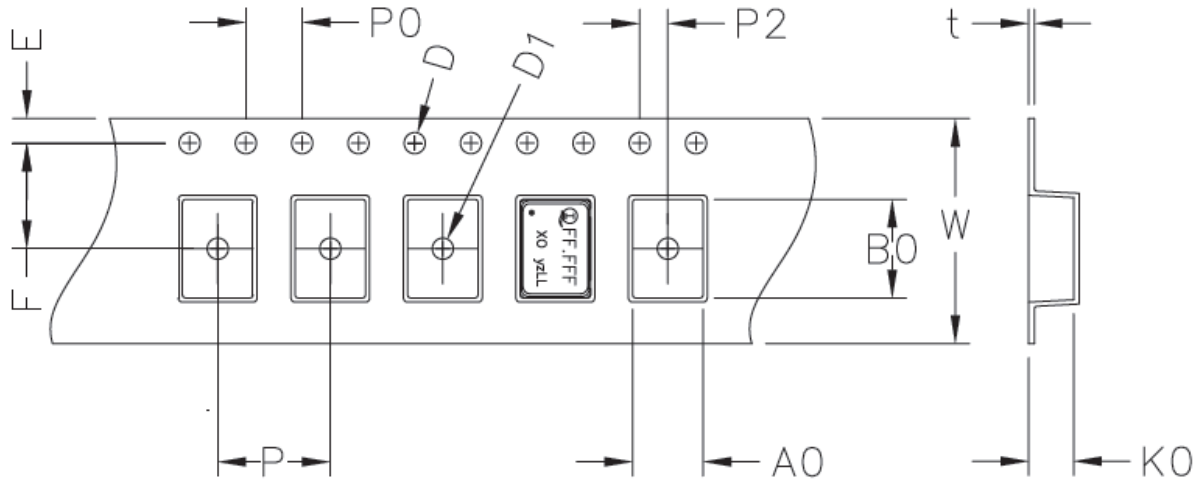

EMBOSSED TYPE DIMENSIONS

ITEM	W+0.3/0.1	A0±0.1	B0±0.1	K0±0.1	P±0.1	F±0.1	t±0.05	Qty
149	16.0	5.5	7.5	2.0	8.0	7.5	0.3	1000

E=1.75±0.1、 D=1.5±0.1、 D1=1.5+0.25/-0.0、 P0=4.0±0.1、 P2=2.0±0.1