



1. Electrical Parameters

MODEL: O22S-1804-10.00MHz						
Item	Description	Parameters			Unit	Test Condition
		Min.	Typ.	Max.		
Output	Frequency	10.00			MHz	
	Output Waveform	LVTTTL				
	Output Low Voltage			0.4	V	$V_{cc}=5.0V$, Load =15pF
	Output High Voltage	2.4			V	$V_{cc}=5.0V$, Load =15pF
	Duty Cycle	45	50	55	%	@50%
	Spurious Suppression			-90	dBc	
	Rise/Fall Time (10%~90%)			3	ns	
	Load	13.5	15	16.5	pF	
	Start up time			1	s	90% V_{CC} to the correct frequency output time
Frequency Stabilities	Frequency Accuracy	-2.0		+2.0	$\times 10^{-6}$	Within 90 days after shipment and 15 minutes warm up time(before reflow), Measurement referenced to nominal frequency
		-0.05		+0.05	$\times 10^{-6}$	Within 90 days after shipment and 5 minutes warm up time(after reflow), Measurement referenced to initial frequency (after 2 hours and 5 minutes warm up time after reflow)
		-0.1		+0.1	$\times 10^{-6}$	After 2 hours and 5 minutes warm up time (after reflow), Measurement referenced to the frequency (before reflow)
	Frequency Stability vs. Operating Temperature Range	-10.0		+10.0	$\times 10^{-9}$	TA varied from 0 to 75°C, $V_{cc}=5.0V$, and Load = 15pF. Measurement referenced to frequency observed With TA = 25°C, $V_{cc}=5.0V$.
	Frequency Tolerance after Temperature compensated vs Operating Temperature Range	-0.3		+0.3	$\times 10^{-9}$	TA varied from 0 to 75°C, $V_{cc}=5.0V$, and Load = 15 pF. Measurement referenced to frequency observed With TA = 25°C, $V_{cc}=5.0V$.



Frequency Stabilities	Short-Term Stability: Allan Variance			0.01	$\times 10^{-9}$	Temperature stability, no EMI\EMC or other interference, test after power for 1hour ref. to 25°C; 1s, using PN9000 equipment.
	Frequency Stability vs. Supply Voltage	-1		1	$\times 10^{-9}$	TA =25°C, Vcc varied from 4.75 to 5.25V and Load =15pF. Measurement referenced to frequency observed with TA = 25°C, V _{cc} =5.0V.
	Frequency Tolerance vs Load	-1		1	$\times 10^{-9}$	10% Load Change Measurement referenced to frequency observed with TA = 25°C, V _{cc} =5.0V.
	Temperature Accuracy			1	°C	TA varied from 0 to75°C,V _{cc} =5.0V, and Load = 15pF. Measurement TA
	Aging Tolerance per day	-0.5		+0.5	$\times 10^{-9}$	Vcc, TA constant Measurement referenced to frequency observed with TA=25°C,V _{cc} =5.0V. and after 30 days of operation
	Aging Tolerance per month	-32		+32	$\times 10^{-9}$	
	Aging Tolerance 1 Years	-0.08		+0.08	$\times 10^{-6}$	
	Aging Tolerance 10 Years	-0.5		+0.5	$\times 10^{-6}$	
Power Supply	Supply Voltage	4.75	5.0	5.25	V	
	Steady Consumption			300	mA	@25°C
	Warm up current			700	mA	When all temp range
	Warm Up Time			5	minute	
	Warm Up	-0.02		+0.02	$\times 10^{-6}$	After warm up 10 minute. Measurement referenced to frequency observed with TA = 25°C,V _{cc} =5.0V. and after 24 hour of operation.
Phase Noise	Phase Noise			-80	dBc/Hz	1Hz
				-120		10Hz
				-140		100Hz
				-145		1KHz
				-150		10KHz
				-150		100KHz



Environmental Conditions	Operable Temperature	-40		85	°C		
	Storage Temperature	-55		105	°C		
	Rate Of Temperature Variation			2	°C/min		
	Air-tightness			0.02	ppm	Not include PCB conversion board.	
	ESD Level	Human Body Model, class2: 2000V to 4000V; ANSI/ESDA/JEDEC JS-001-2010.					
		Machine Model, class B: 200V to 400V; ANSI/ESDA/JEDEC JS-001-2010.					
	Moisture Sensitivity Level	Level 2.					
	Vibration	Test Condition: 0.75mm ;acceleration:10g;10Hz~500Hz, one cycle per 30 min, test 2 hour. (3 times for each 3 directions X ,Y , Z), IEC 68-2-06 Test Fc.					
Shock	50g; 11ms; half sine wave (3 times for each 3 directions X ,Y, Z),IEC 68-2-27 Test Ea/Severity 50A.						
Full Package Storage	Relative humidity (%)	20% ~ 70%					
	Temperature (°C)	-10~35°C					



2. Mechanical Structure (mm)

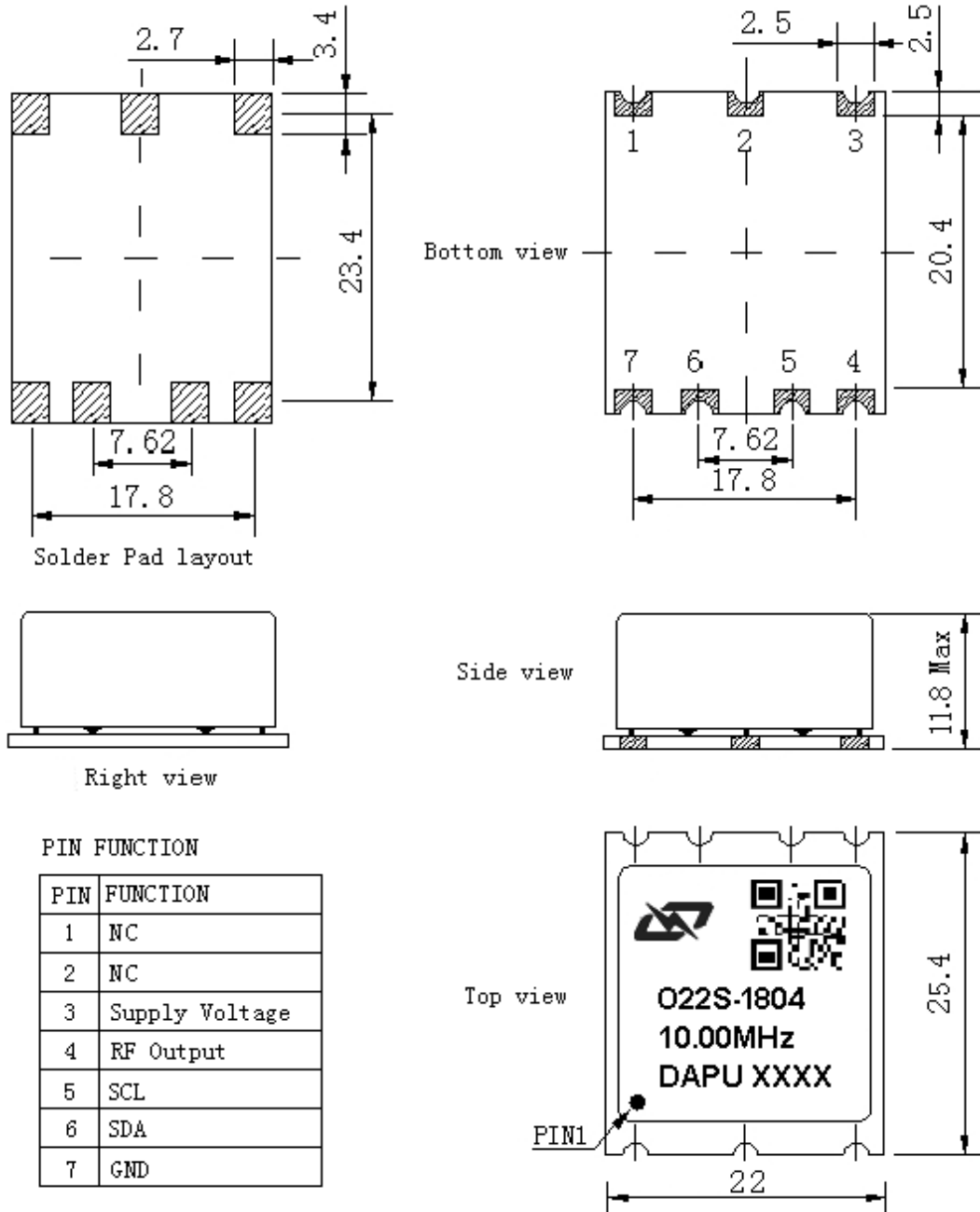

- Note1:** Tolerance $\pm 0.20\text{mm}$ without mark
- Note2:** The first two xx representative: week
After two xx representative: year
- Note3:** Referential weight 10g
- Note4:** NC is not connect



3. I²C Devices Address

3.1. 2kbit I²C SERIAL EEPROM

Device name : AT24C2

Device supplier : Atmel

Device address : 1010100

Memory map

Parameter	Measured value	Calculation	Register
Serial number	SN111	ASCII	0x00-0x0F
Supplier Product ID	O22S-1804-10.00MHz	ASCII	0x10-0x87
Date of calibration	YYYY-MM-DD	ASCII	0x88-0x91
Reserved for Supplier	000000...	HEX	0x92-0xAD
Vtemp : internal temperature indicator	TBD	$2^{32} * Vtemp$	0xAE-0xB5
Vtemp min	TBD	$2^{32} * Vtemp$ min	0xB6-0xBD
Vtemp max	TBD	$2^{32} * Vtemp$ max	0xBE-0xC5
A0		$2^{32} * (2^{32} + A_0)$	0xC6-0xCD
A1		$2^{32} * A_1$	0xCE-0xD5
A2		$2^{32} * (2^{32} + A_2)$	0xD6-0xDD
A3		$2^{32} * A_3$	0xDE-0xE5
B0		$2^{32} * (2^{32} + B_0)$	0xEE-0xED
B1		$2^{32} * B_1$	0xEE-0xF5

Temperature compensation formula:

$$A_3 v^3 + A_2 v^2 + A_1 v + A_0 = \frac{f(v) - f(v_{ref})}{f(v_{ref})}$$

 A_x = coefficients stored to internal memory (see memory map)

v = Vtemp value

f (v) = measured frequency

Vref = Vtemp reading at reference temperature (25°C)

The residual error shall be such that:

OCXO Ambient temperature calculation formula:

$$B_1 v + B_0 = Ta [^{\circ}C]$$



3.2. Analog-to-Digital Converter

Device name : ADC081C027

Device supplier : TI

Device address : 1010000

Note: More detailed information see the datasheet provide by the TI.

4. Test Circuit

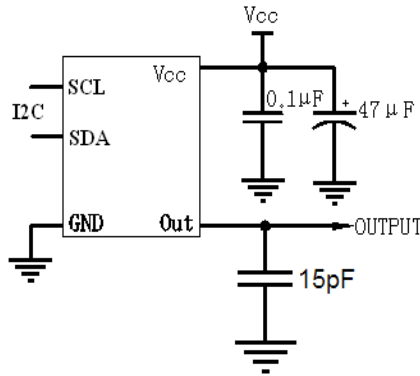

5. Reflow Soldering Curve (RoHS)

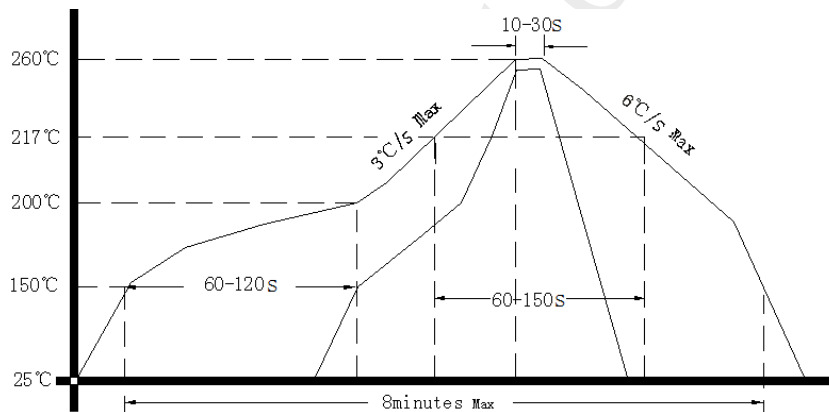

6. Package: Tape & Reel (mm)

