





### Table of amendment

Version	Revision contents	Prepared by	Revised date
1.0	The first issued	Amway	2017.09.14
1.1	Add "Frequency Stability Over Any 15°C Of Ambient Temperature" "G-sensitivity" "Air flow". Changed "Aging Tolerance Per Day" "Steady Consumption" "Warm up current" "Mechanical Structure".	Amway	2017.11.10
1.2	Add "8 hours Holdover"	Amway	2017.11.27



## 1. Electrical Parameters

MODEL: O22B-1803-10.00MHZ						
Item	Description	Parameters			Unit	Test Condition
		Min.	Typ.	Max.		
Output	Frequency	10.00			MHz	
	Output Waveform	HCMOS				
	Output Low Voltage	0		0.8	V	$V_{cc}=5.0V, O_{load}=15pF$
	Output High Voltage	3.4		4.6	V	$V_{cc}=5.0V, O_{load}=15pF$
	Duty Cycle	45	50	55	%	@50%
	Rise / Fall Time (10%~90%)			10	ns	
	Load	15			pF	
Frequency Stabilities	Frequency Tolerance vs. Operating Temperature Range	-0.5		+0.5	$\times 10^{-9}$	$T_A$ varied from $-40^{\circ}C$ to $85^{\circ}C$ , measurement referenced to frequency observed with $f_{ref}=(f_{max}+f_{min})/2, V_{cc}=5.0V, V_c=2.0V, O_{load}=15pF$ , temperature variable speed less than $2^{\circ}C$ per minute.
	Frequency Stability Over Any $10^{\circ}C$ Of Ambient Temperature	-0.05		+0.05	$\times 10^{-9}$	$T_A$ varied from $-40^{\circ}C$ ~ $85^{\circ}C$ , measurement relative to the frequency at the start of the $10^{\circ}C$ window, temperature variable more than $0.5^{\circ}C$ per minute.
	Initial Frequency Tolerance	-0.1		+0.1	$\times 10^{-6}$	Measurement referenced to frequency observed with $T_A=25^{\circ}C, V_{cc}=5.0V, V_c=2.0V$ , and after 15 minutes of operation, within 30 days after ex-works.
	Frequency Tolerance vs. Supply Voltage	-0.2		+0.2	$\times 10^{-9}$	measurement referenced to frequency observed $T_A=25^{\circ}C, V_{cc}$ varied from 4.75V to 5.25V, $V_c=2.0V$ and $O_{Load}=15pF$ .
	Frequency Tolerance vs. Load	-0.2		+0.2	$\times 10^{-9}$	5% load change measurement referenced to frequency observed with $T_A=25^{\circ}C, V_{cc}=5.0V, V_c=2.0V$ , and $O_{Load}=15pF$ .
	Short-Term Stability: Allan Variance			0.01	$\times 10^{-9}$	Temperature stability, no EMI\EMC or other interference, test after power for 1hour ref. to $25^{\circ}C$ ; 1s, using PN9000 equipment.
	8 hours Holdover	-2		+2	$\mu s$	$\pm 15^{\circ}C$ temperature variation, gradient $0.5^{\circ}C$ /minute
	Aging Tolerance Per Day	-0.1		+0.1	$\times 10^{-9}$	After 30 days of operation, 4 sigma(99.38%) all clauses
	Aging Tolerance 1 Year	-0.03		+0.03	$\times 10^{-6}$	After 30 days of operation.
	G-sensitivity			3	$\times 10^{-9}/G$	



Power Supply	Supply Voltage	4.75	5.0	5.25	V	
	Steady Consumption			350	mA	@25°C
	Warm up current			700	mA	
	Warm up time			5	minutes	@25 °C within $\pm 0.05 \times 10^{-6}$ of final frequency with reference after 1 hour on.
Voltage Control Characteristics	Frequency Tuning Range	-0.5		-0.3	$\times 10^{-6}$	$V_c=0V$ . measurement referenced to $V_c=2.0V$
		-0.1		+0.1	$\times 10^{-6}$	$V_c=2.0V$ . measurement referenced to exactly 10.00MHz
		+0.3		+0.5	$\times 10^{-6}$	$V_c=4.0V$ . measurement referenced to $V_c=2.0V$
	Linearity			10	%	
	Slope	Positive				
	Input Impedance	100			K $\Omega$	
Phase Noise	Phase Noise		-130	-120	dBc/Hz	10Hz
			-145	-140		100Hz
			-155	-150		1KHz
			-158	-155		10KHz
			-158	-155		100KHz
			-160	-155		1MHz
Environmental Conditions	Operable Temperature	-40		+85	°C	
	Storage Temperature	-55		+105	°C	
	Air flow	0		3	m/s	@-40°C~85°C
	ESD Level	Human Body Model, class2: 2000V to 4000V; ANSI/ESDA/JEDEC JS-001-2010.				
		Machine Model, class B: 200V to 400V; ANSI/ESDA/JEDEC JS-001-2010.				
	Moisture Sensitivity Level	Not humidity sensitive.				
	Vibration	Test Condition: 0.75mm ;acceleration:10g;10Hz~500Hz, one cycle per 30 min, test 2 hour. (3 times for each 3 directions X , Y , Z), IEC 68-2-06 Test Fc.				
Shock	50g; 11ms; half sine wave (3 times for each 3 directions X, Y, Z), IEC 68-2-27 Test Ea/Severity 50A.					
Full Package Storage	Relative humidity (%)	20%~70%				
	Temperature (°C)	-10~35°C				



## 2. Mechanical Structure (mm)

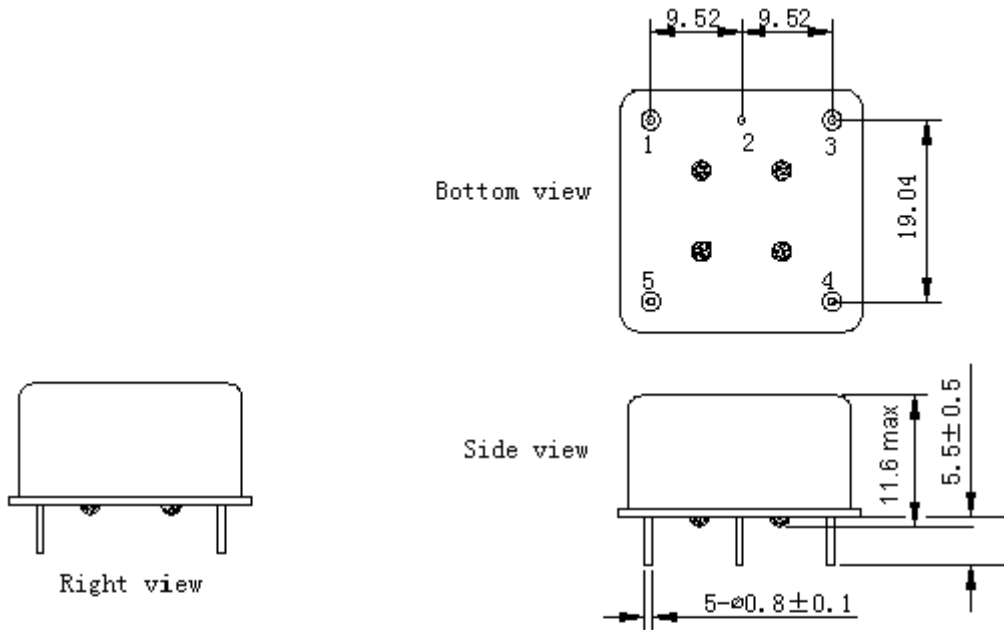

### PIN FUNCTION

PIN	NOTATION	FUNCTION
1	OUTPUT	RF Output
2	GND	GND
3	VC	Control Voltage
4	VREF	4.0V
5	WCC	Supply Voltage

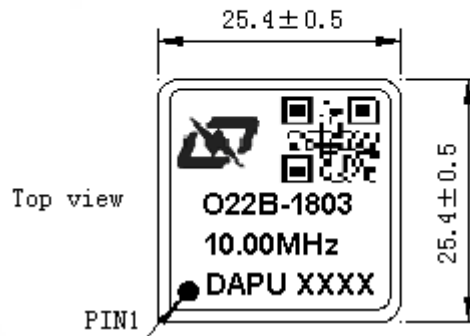

- Note1:** Tolerance ±0.2mm without mark
- Note2:** The first two xx representative: week  
After two xx representative: year
- Note3:** Referential weight 13.6g



### 3. Test Circuit

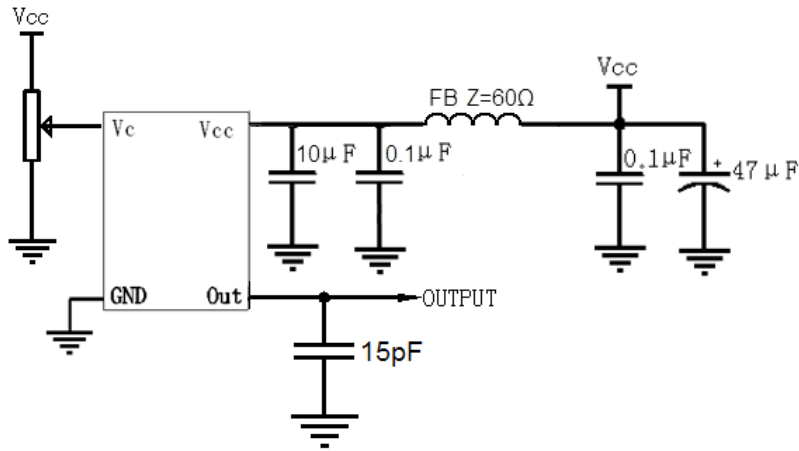

### 4. Reflow Soldering Curve (RoHS)

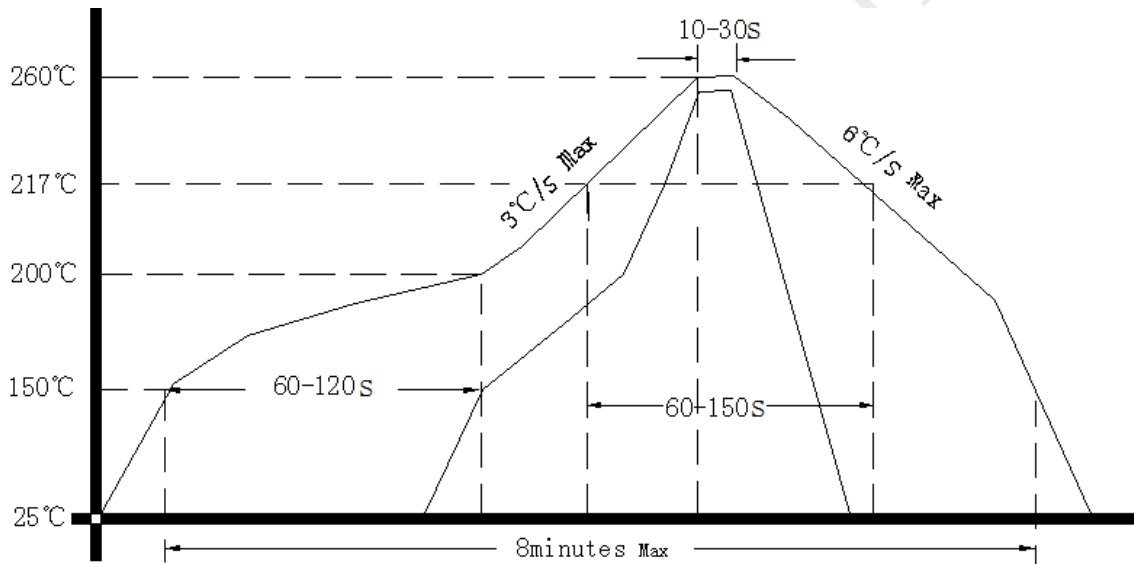

### 5. Package (mm)

