

Travelling Merchant: _____

DATASHEET

Standard: M11A-DCAD-10.00MHz

Plot			The Label
Drawing	Auditing	Approve	Stamp, please! Thanks!
Date: 09-06-25			

Dongguan Dapu Telecom Technology Co.,Ltd

No.1 New City Street,Songshan Lake Science Park, Dongguan City,Guangdong province, PRC CHINA

TEL: 0086-0769-88010888 FAX: 0086-0769-81800098



The parameter of product

MODEL: M11A-DCAD-10.00MHz

1. Output

1.1. Nominal Frequency	10.00MHz
1.2. Waveform	HCMOS
	Voh ≥ 2.7V, Vol ≤ 0.4V
1.3. Duty cycle	45%~55% @50%
1.4. Rise / Fall time (10%~90%)	≤ 6ns @15pF
1.5. Load	15pF

2. Frequency Stabilities

2.1. Stability vs. operating temp. rang	≤ ±1.0x10 ⁻⁷	@-40°C ~ +85°C ref. to 25 °C
2.2. Initial tolerance	≤ ±5.0x10 ⁻⁷	@VC=1.65V, 25°C
2.3. Stability vs. supply voltage change	≤ ±5.0x10 ⁻⁸	@3.3VDC±5%
2.4. Stability vs. Load change	≤ ±5.0x10 ⁻⁸	@15pF±5%
2.5. Aging	≤ ±2.0x10 ⁻⁸ / day	
	≤ ±1.0x10 ⁻⁶ / first year	

3. Supply Voltage

3.1. Supply Voltage	+3.3VDC±5%
---------------------	------------

4. Current

4.1. Current consumption	10mA(Typical)
--------------------------	---------------

5. Electrical frequency adjustment

5.1. Control voltage	0~3.3VDC (VC=1.65V)
5.2. Linearity	≤ ±10%
5.3. Frequency adjustment	≥ ±8ppm
5.4. Slope	Positive
5.5. Input Impedance	≥ 100KΩ

6. Phase noise (Typical)

6.1. 10Hz	-90dBc/Hz
6.2. 100Hz	-115dBc/Hz
6.3. 1KHz	-135dBc/Hz
6.4. 10KHz	-145dBc/Hz
6.5. 100KHz	-145dBc/Hz

7. Environmental conditions

7.1. Operable temperature range	-40°C to +85°C
---------------------------------	----------------



- 7.2. Storage temperature range -55°C to +125°C
- 7.3. Vibration IEC 60068-2-6 Test Fc, 10~55Hz, 0.75mm displacement, 30 minutes in each of three mutually perpendicular axes at 1 octave per minute
- 7.4. Shock IEC 60068-2-27 Test Ea, 1000m/S² acceleration for 6ms duration, 3 shocks in each direction along three mutually perpendicular axes.

8. Mechanical

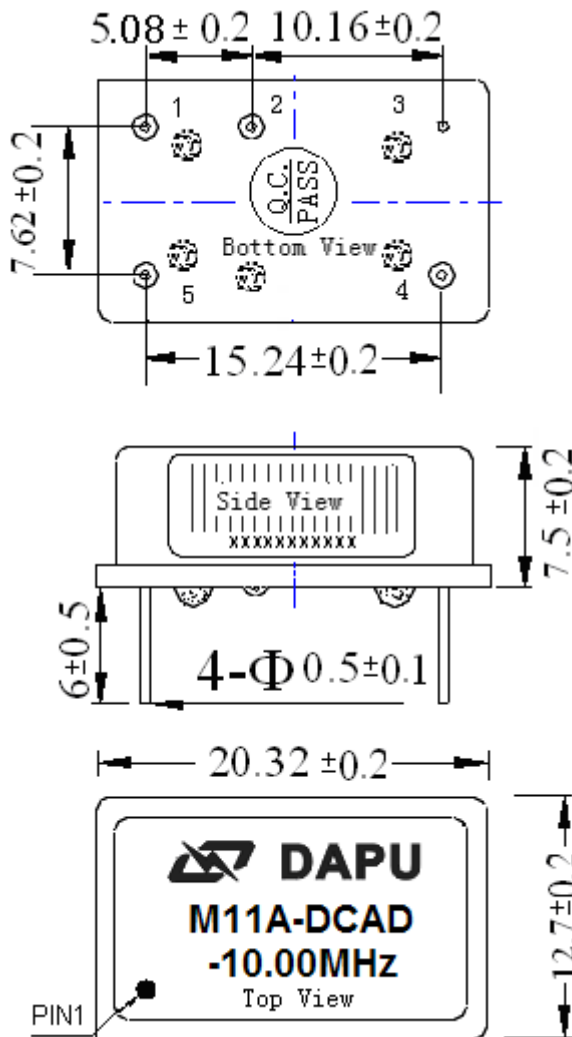

PIN FUNCTION

PIN	FUNCTION
1	Control Voltage
2	NC
3	GND
4	Output
5	Supply Voltage

Note: The bottom view means that the stitches are against the people

Unit : mm



9. Test circuit

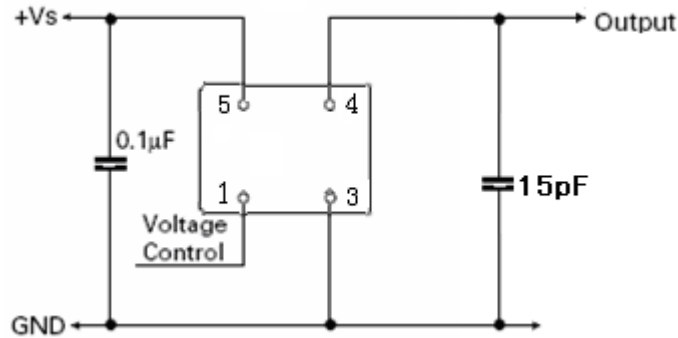

10. Recommended Reflow Profile

Solderprofile:

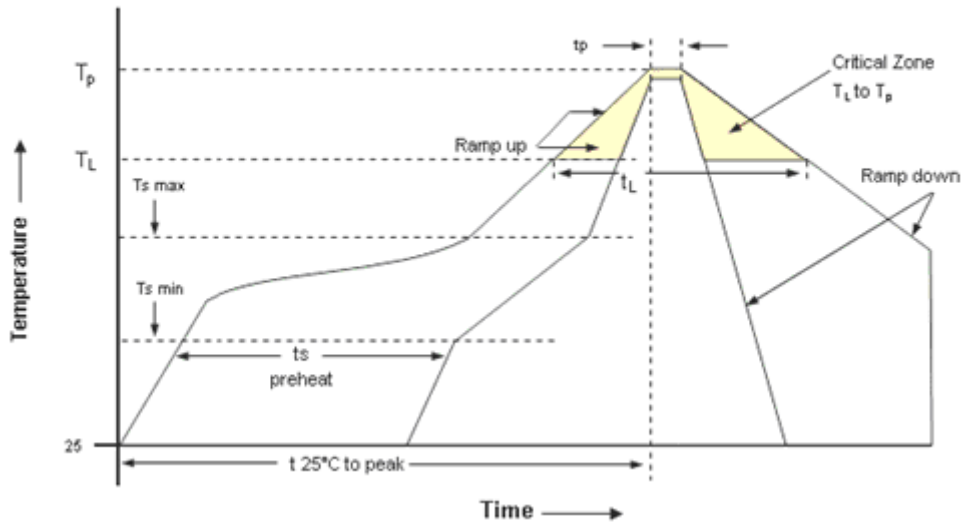

Profile Feature	Pb-Free Assembly	Profile Feature	Pb-Free Assembly
Average ramp-up rate (T_L to T_p)	3°C/second max.	Time 25°C to Peak Temperature	8 minutes max.
Preheat -Temperature Min $T_{s_{min}}$ -Temperature Min $T_{s_{max}}$ -Time (min to max) (t_s)	150°C 200°C 60-180 seconds	Time maintained above - Temperature (T_L) - Time (t_L)	217°C 60-150 seconds
$T_{s_{max}}$ to T_L - Ramp-up Rate	3°C/second max.		
Time maintained above - Temperature (T_L) - Time (t_L)	217°C 60-150 seconds	Time within 5°C of actual Peak Temperature (t_p)	20-40 seconds
Peak Temperature (T_p)	max 260°C	Ramp-down Rate	6°C/second max.

Note: All temperatures refer to topside of the package, measured on the package body surface.