



Travelling Merchant: _____

DATASHEET

Standard: **O11S-M319-20.00MHz**

P/N: _____

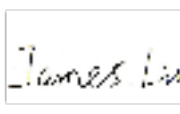
Plot			The Label
Drew	Audited	Approved	Stamp, please! Thanks!
			
Date: 2012.03.09			

Guangdong Dapu Telecom Technology Co.,Ltd

Bldg13-16,.N.Ind.Zone,SSL Industry Park, Dongguan City, Guangdong Province, China

TEL: 0086-0769-88010888 FAX: 0086-0769-81800098



1、Electrical Parameters

MODEL: O11S-M319-20.00MHz						
Item	Description	Parameters			Unit	Test Condition
		Min.	Typ.	Max.		
Output	Frequency	20.00			MHz	
	Output Waveform	HCMOS				
	Output Low Voltage			0.4	V	$V_{cc}=3.3V, O_{load}=15pF$
	Output High Voltage	2.4			V	$V_{cc}=3.3V, O_{load}=15pF$
	Duty Cycle	45	50	55	%	@50%
	Rise / Fall Time (10%~90%)			5	ns	
	Load	15			pF	
	Start-up Time			5	ms	90% of final amplitude
Frequency Stabilities	Frequency Tolerance vs. Operating Temperature Range	-0.1		+0.1	$\times 10^{-6}$	T_A varied from $-40^{\circ}C$ to $85^{\circ}C$, measurement referenced $(F_{MAX}+F_{MIN})/2$, temperature variable speed less than $2^{\circ}C$ per minute.
	Initial Frequency Tolerance	-0.5		+0.5	$\times 10^{-6}$	Measurement referenced to frequency observed with $T_A=25^{\circ}C$, $V_{cc}=3.3V$, and after 15 minutes of operation, within 30 days after ex-works.
	Slope	-0.01		+0.01	$\times 10^{-6}/^{\circ}C$	Temperature ramp $1^{\circ}C/minute$.
	Frequency Tolerance vs. Supply Voltage	-0.05		+0.05	$\times 10^{-6}$	Measurement referenced to frequency observed $T_A=25^{\circ}C$, V_{cc} varied from 3.13V to 3.47V, and $O_{Load}=15pF$.
	Frequency Tolerance vs. Load	-0.05		+0.05	$\times 10^{-6}$	5% load change measurement referenced to frequency observed with $T_A=25^{\circ}C$, $V_{cc}=3.3V$, $O_{Load}=15pF$.
	Short-Term Stability: Allan Variance			0.1	$\times 10^{-9}$	Temperature stability, no EMI/EMC or other interference, test after power for 1 hour ref. to $25^{\circ}C$; 1s, using PN9000 equipment.
	Aging Tolerance Per Day	-5		+5	$\times 10^{-9}$	V_{cc}, T_A constant measurement referenced to frequency observed with $T_A=25^{\circ}C$, $V_{cc}=3.3V$, and after 30 days of operation.
	Aging Tolerance 1 Year	-1		+1	$\times 10^{-6}$	
	Holdover 24 hours Drift	-0.02		+0.02	$\times 10^{-6}$	At constant temperature, after 48 hours of continuous operation.



	Overall Stability	-4.6		+4.6	$\times 10^{-6}$	Inclusive of the following: - operating temperature -40°C to 85°C - 3.3V±5% - 15pF load ±5% - 2 times reflow soldering - 10 years aging reference to nominal frequency
Power Supply	Supply Voltage	3.13	3.3	3.47	V	
	Steady Consumption			150	mA	@25°C
	Warm-up Time			3	minute	@25°C within $\pm 0.02 \times 10^{-6}$ of final frequency with reference after 1 hour on.
	Warm up current			400	mA	
Phase Noise	Phase Noise		-85	-82	dBc/Hz	10Hz
			-115	-112		100Hz
			-135	-132		1KHz
			-145	-142		10KHz
			-148	-145		100KHz
			-150	-147		1MHz
Environmental Conditions	Operable Temperature	-40		+85	°C	
	Storage Temperature	-55		+105	°C	
	ESD Level	Human Body Model,class2: 2000V to 4000V; ANSI/ESDA/JEDEC JS-001-2010.				
		Machine Model, class B: 200V to 400V; ANSI/ESDA/JEDEC JS-001-2010.				
	Moisture Sensitivity Level	Level 2.				
	Vibration	Test Condition: 0.75mm ;acceleration:10g;10Hz~500Hz, one cycle per 30 min, test 2 hour. (3 times for each 3 directions X ,Y , Z), IEC 68-2-06 Test Fc.				
Shock	50g; 11ms; half sine wave (3 times for each 3 directions X ,Y, Z),IEC 68-2-27 Test Ea/Severity 50A.					



2、 Mechanical Structure(mm)

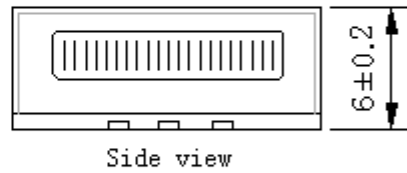
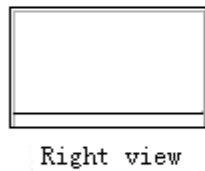
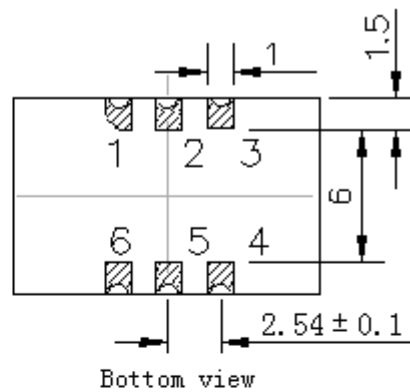
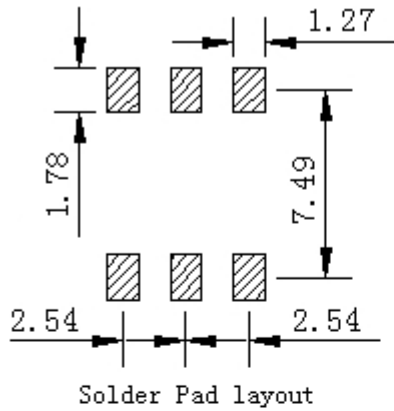

PIN FUNCTION

PIN	FUNCTION
1	NC
2,5	NC
3	GND
4	OUTPUT
6	VCC

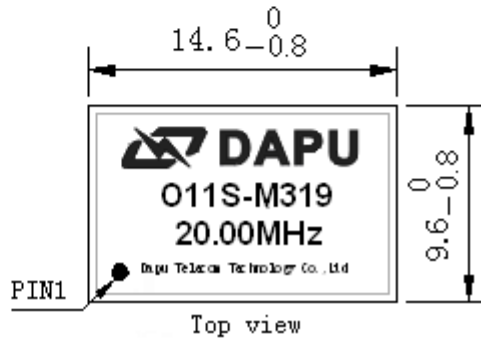

Note1: Tolerance $\pm 0.2\text{mm}$ without mark

Note2: Referential Weight 3.8g

Note3: NC is not connect

3、 Test Circuit

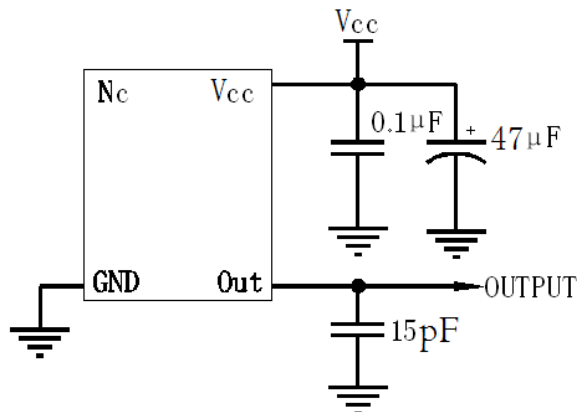



4、 Reflow Soldering Curve (RoHS)

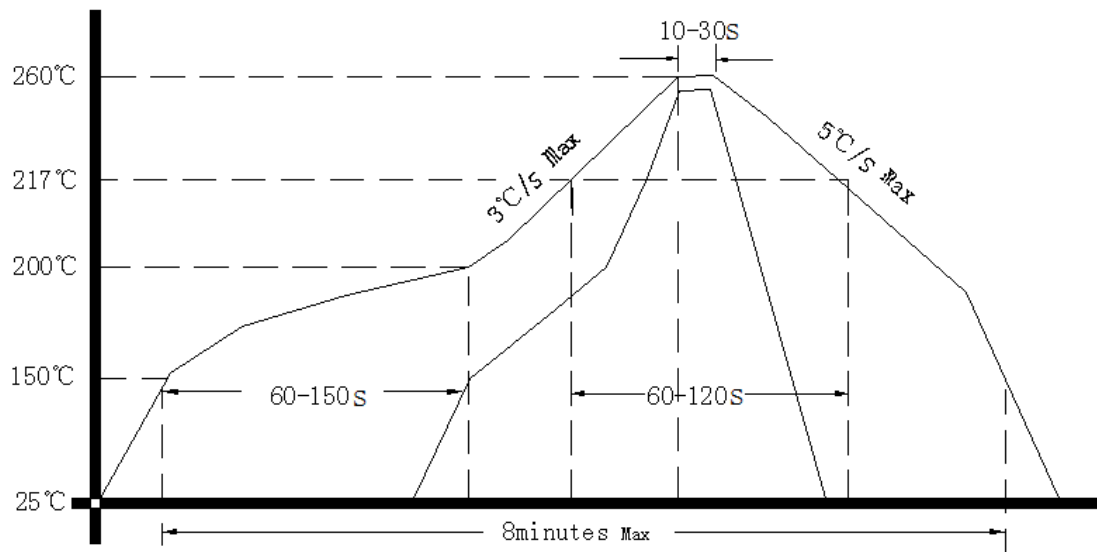

5、 Package: Tape & Reel (mm)

