



1. Electrical Parameters

MODEL: O11H-2104-20.00MHz						
Item	Description	Parameters			Unit	Test Condition
		Min.	Typ.	Max.		
Output	Frequency	20.00			MHz	
	Output Waveform	LVCMOS				
	Output Low Voltage			0.4	V	$V_{cc}=3.3V, O_{load}=15pF$
	Output High Voltage	2.4			V	$V_{cc}=3.3V, O_{load}=15pF$
	Duty Cycle	45	50	55	%	$\pm 5\%$
	Rise / Fall Time (10%~90%)			5	ns	
	Start-up Time			100	ms	
	Spurious Suppression			-70	dBc	
	Load	13.5	15	16.5	pF	$\pm 10\%$
Frequency Stabilities	Frequency Tolerance vs. Operating Temperature Range			± 5	$\times 10^{-9}$	T_A varied from $-40^\circ C$ to $85^\circ C$, measurement referenced to frequency observed with $f_{ref}=(f_{max}+f_{min})/2, V_{cc}=3.3V, O_{load}=15pF$, temperature variable speed less than $2^\circ C$ per minute.
	Initial Frequency Tolerance			± 0.2	$\times 10^{-6}$	Measurement referenced to frequency observed with $T_A=25^\circ C, V_{cc}=3.3V$, and after 15 minutes of operation, within 30 days after ex-works.
	Frequency Tolerance vs. Supply Voltage			± 5	$\times 10^{-9}$	No overshooting on frequency plot
	Frequency Tolerance vs. Load			± 5	$\times 10^{-9}$	10% load change measurement referenced to frequency observed with $T_A=25^\circ C, V_{cc}=3.3V$, and $O_{Load}=15pF$.
	Frequency slope at Temperature Range			± 1	$\times 10^{-9}/^\circ C$	T_A varied from $-40^\circ C$ to $85^\circ C$, measurement referenced to frequency observed with $T_A=25^\circ C, V_{cc}=3.3V, O_{load}=15pF$, temperature variable speed less than $2^\circ C$ per minute.
	Resistance to reflow Soldering			± 0.4	$\times 10^{-6}$	
	Anti-airflow			± 5	$\times 10^{-9}$	@ $60^\circ C$
G-sensitivity			3	$\times 10^{-9}/g$		
Compliant to Clock Stratum :3E compliant per GR-1244-Core Telcordia						



	ADEV			0.05	$\times 10^{-9}$	ADEV 1sec.
				0.1	$\times 10^{-9}$	ADEV 10sec.
				0.2	$\times 10^{-9}$	ADEV 100sec.
				0.3	$\times 10^{-9}$	ADEV 1000sec.
				0.6	$\times 10^{-9}$	ADEV 10000sec.
	Aging Tolerance Per Day			± 1	$\times 10^{-9}$	V _{cc} ,T _A constant measurement referenced to frequency observed withT _A =25°C,V _{cc} =3.3V, and after 30 days of operation.
	Aging Tolerance Per Month			± 0.025	$\times 10^{-6}$	
	Aging Tolerance 1 Year			± 0.2	$\times 10^{-6}$	
	Aging Tolerance 10 Years			± 0.8	$\times 10^{-6}$	
	Aging Tolerance 15 Years			± 1	$\times 10^{-6}$	
Overall stability			± 2	$\times 10^{-6}$	Inclusive of the following: - operating temperature -40°C to 85°C - 3.3V $\pm 5\%$ - 15pF load $\pm 5\%$ - 2 times reflow soldering - 15 years aging reference to nominal frequency	
Drift			± 2	$\times 10^{-9}$	24hours @25°C	
Frequency Retrace			± 0.05	$\times 10^{-6}$	@25°C, after stabilization /24h Off & 1h On	
Power Supply	Supply Voltage	3.13	3.3	3.47	V	$\pm 5\%$
	Steady Consumption			300	mA	@25°C
	Warm up current			750	mA	
	Warm-Up Time			3	minutes	< ± 100 ppb of final frequency after 1 hour power-on
Phase Noise	Phase Noise			-75	dBc/Hz	1Hz
				-105		10Hz
				-130		100Hz
				-145		1KHz
				-150		10KHz
				-150		100KHz
				-150		1MHz
Jitter			1.0	ps	RMS(12KHz to 20MHz)	



Environmental Conditions	Operable Temperature Range	-40		+85	°C	
	Storage Temperature	-55		+105	°C	
	ESD Level	Human Body Model, class2:2000Vto4000V; ANSI/ESDA/JEDEC JS-001-2010.				
		Machine Model, class B: 200V to 400V; ANSI/ESDA/JEDEC JS-001-2010.				
	Moisture Sensitivity Level	Level 2.				
	Vibration	20G, 20-2000Hz 4x in each 3axis 4 min				
	Thermal Shock	0.5h@-55°C, 0.5h@+125°C, switching time ≤ 5min, 100 cycles				
	Shock	1500g, 0.5ms duration,1/2 sine wave, 3 shocks for each direction, Severity 50A.				
Full Package Storage	Relative humidity (%)	20% ~ 70%				
	Temperature (°C)	-10~35°C				



2. Mechanical Structure (mm)

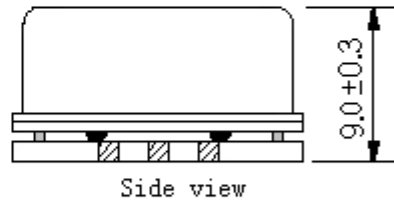
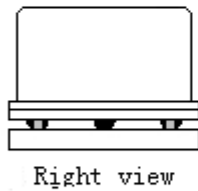
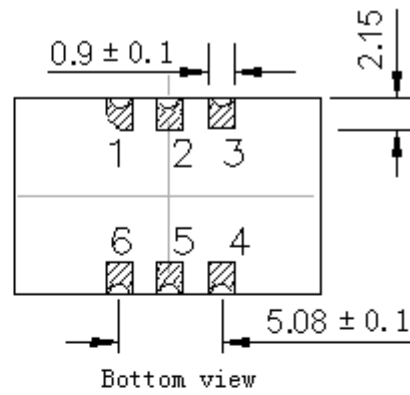
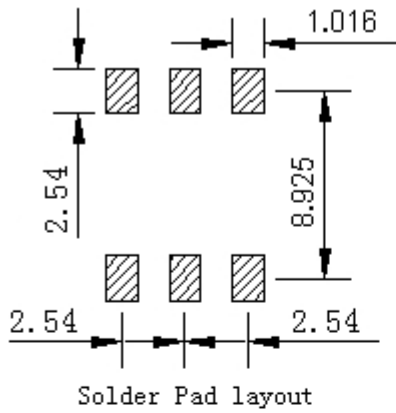

PIN FUNCTION

PIN	NOTATION	FUNCTION
1	NC	Not Connect
2,5	NC	Not Connect
3	GND	GND
4	OUTPUT	RF Output
6	VCC	Supply Voltage



- Note1:** Tolerance $\pm 0.2\text{mm}$ without mark
- Note2:** Referential weight 2.6g
- Note3:** The first two xx representative: week
After two xx representative: year
- Note4:** NC is not connect



3. Test Circuit

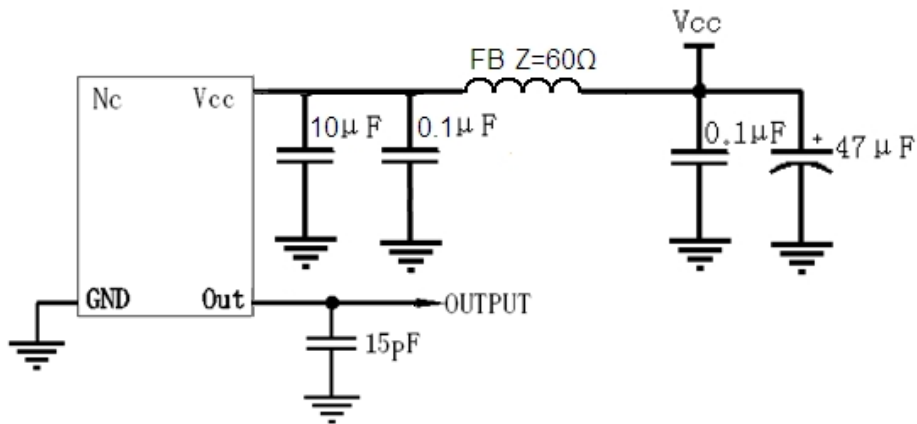

4. Reflow Soldering Curve (RoHS)

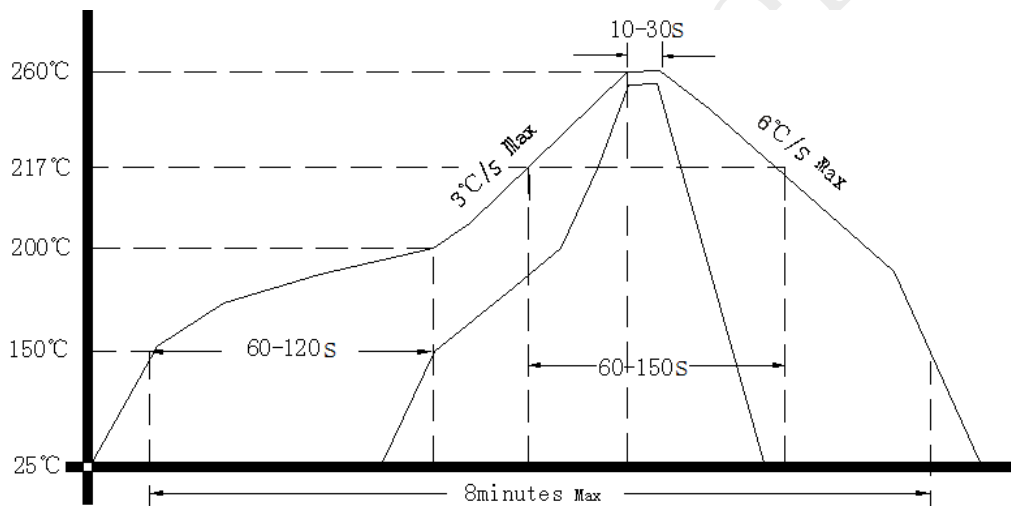

5. Package: Tape & Reel (mm)

